

## CARTRIDGE DUST COLLECTORS DCM600 TO DCM1800

220 V / 380 V



- Warranty
- Safety
- Operation

- Service Parts
- Accessory Information
- Registration Form



# INSTRUCTION MANUAL

2023-11-14

**TABLE OF CONTENTS**

	<b>Page</b>
INTRODUCTION - NOTICE TO PURCHASERS .....	3
GENERAL SAFETY RULES - PERSONAL SAFETY USE - AND EQUIPMENT MAINTENANCE.....	4
SPECIFICATIONS - HOW IT WORKS .....	5
GENERAL DESCRIPTION .....	6
INSTALLATION .....	7, 8
DRAINING DUST - OPERATION - ADJUSTMENTS.....	9
CARTRIDGE DUST COLLECTOR - GENERAL PARTS LIST .....	10
FAN MOTOR & SUCTION HOSE .....	11
MUFFLERS .....	12
DIAGRAMS (MOUNTING CARTRIDGES) .....	13
CARTRIDGE MEDIA .....	14
PREVENTIVE MAINTENANCE SCHEDULE .....	15
DCT1000 TIMER CONTROLLER - PERIODICAL ADJUSTMENTS .....	16 TO 18
OPTIONAL HEPA FILTER - SPECIFICATIONS LIST .....	19, 20
CLOGGING SYSTEM .....	21
ELECTRICAL BOX - SOLENOIDE VALVES .....	22
TROUBLESHOOTING .....	23, 24
PREVENTIVE MAINTENANCE - CARTRIDGES: REPLACEMENT, CLOGGING, CLEANING .....	25
PNEUMATIC DAIGRAM.....	26
ELECTRICAL SCHEMATICS .....	27 TO 31
SEQUENTIAL CONTROLLER .....	32 TO 48
ISTBLAST LIMITED WARRANTY .....	49
ISTBLAST WARRANTY REGISTRATION .....	50
INFORMATION- TECHNICAL ASSISTANCE .....	51
ABOUT THE COMPANY .....	52

## INTRODUCTION

The products described in this material, and the information relating to those products, is intended for knowledgeable, experienced users of abrasive blasting equipment.

No representation is intended or made as to the suitability of the products described herein for any particular purpose of application. No representations are intended or made as to the efficiency, production rate, or the useful life of the products described herein.

Any estimate regarding production rates or production finishes are the responsibility of the user and must be derived solely from the user's experience and expertise, and must not be based on information in this material.

The products described in this material may be combined by the user in a variety of ways for purposes determined solely by the user. No representations are intended or made as to the suitability or engineering balance of the combination of products determined by the user in his selection, nor as to the compliance with regulations or standard practice of such combinations of components or products.

It is the responsibility of the knowledgeable, experienced users of the products mentioned in this material to familiarize themselves with the appropriate laws, regulations and safe practices that apply to these products, equipment that is connected to these products and materials that may be used with these products.

It is the responsibility of the user to insure that proper training of operators has been performed and a safe work environment is provided.

Our company is proud to provide a variety of products to the abrasive blasting industry, and we have confidence that the professionals in our industry will utilize their knowledge and expertise in the safe efficient use of these products.

## NOTICE TO PURCHASERS AND USERS OF OUR PRODUCTS AND THIS INFORMATIONAL MATERIAL

**Welcome to the ISTblast® family of sandblasting products. This booklet contains helpful information and acquaints you with the operation and maintenance of your equipment. Please read carefully and follow our recommendations to assure trouble free operation. If you have any questions, please do not hesitate to contact your distributor or our technical service.**

1. Carefully inspect the shipping carton for any signs of transport damage. The damage to the carton often indicates possibility of transport damage to the equipment inside.
2. Carefully remove your ISTblast dust collector from the shipping carton and skid.
3. Check your equipment immediately to ensure that it is free of transport damage. Report any transport damage to the carrier without delay for possible claim procedures. ISTblast is not responsible for damage to equipment after it leaves our warehouse.
4. Check the equipment received and compare it with the parts you have received. If any parts are missing, contact the supplier you purchased the equipment from.

Before operating the ISTblast dust collector, read this Instruction Manual completely. All ISTblast products are engineered and manufactured to the highest performance standards and have been subjected to detail testing before shipment from the factory.



**⚠ WARNING ⚠**

« READ ALL INSTRUCTIONS » Failure to follow the SAFETY RULES identified by a BULLET (○) symbol listed BELOW and other safety precautions may result in serious personal injury.

« SAVE THESE INSTRUCTIONS »

**GENERAL SAFETY RULES**

- **KEEP WORK AREA CLEAN.**
- **KEEP CHILDREN AWAY.** Do not let visitors come in contact with the equipment. All visitors should be kept away from the work area.

**PERSONAL SAFETY**

- **GUARD AGAINST ELECTRIC SHOCK.** Non-skid footwear is recommended where damp or wet ground may be encountered. A ground fault circuit interrupter protected power line must be used for these conditions.
- **DRESS PROPERLY.** Do not wear loose clothing or jewelry. They can be caught in the moving parts. Wear protective hair covering to contain long hair.
- **USE SAFETY EQUIPMENT. WEAR SAFETY GOGGLES** or glasses with side shields.
- **WEAR A DUST PROOF MASK.**
- **STAY ALERT. USE YOUR COMMON SENSE.** Concentrate on what you are doing. Do not operate the unit when you are tired or under the influence of drugs or alcohol.
- **DO NOT OVERREACH.** Keep proper footing and balance at all times.

**USE AND EQUIPMENT MAINTENANCE**

- **BEFORE CONNECTING THE UNIT** to an electric current, make sure that the current is the same as that indicated on the identification plate of the collector. An electric current higher than indicated that could seriously injure the user and also damage the collector. If you have any doubts, do not connect the unit.
- **DO NOT FORCE THE EQUIPMENT.** It will perform better and more safely if It will perform according to the manufacturer's specifications and without hazards
- **USE OF ANY OTHER ACCESSORIES** not specified in this manual may be dangerous.
- **DISCONNECT THE UNIT** on its maintenance.
- **DO NOT ALTER OR IMPROPERLY USE THE UNIT.** These units are precision equipment. Alteration unspecified or modification can lead to a dangerous situation. Only a qualified technician should make all repairs (•), whether electrical or mechanical. Contact your nearest repair ISTblast service. Use only ISTblast original parts, the use of other parts carries a risk.

PRESSION DE TRAVAIL  
**MAXIMUM**  
 WORKING PRESSURE

**552** KPa

**80** psi (lb/po<sup>2</sup>)

**WARNING**  
 After motor is connected  
 check if rotation is  
 corresponding  
 with arrow.

**ATTENTION**  
 Après branchement  
 vérifier si la direction  
 de rotation correspond à  
 la flèche.

## SPECIFICATIONS

DESCRIPTION	DCM 600	DCM 900	DCM 1200	DCM 1800
Cartridge number	2		4	
Filtration (sqft)	562	562	1124	1124
Recycler	13	16	26	30
Motor (hp)	1	2	3	5
Turbine (cfm)	600	900	1200	1800
Turbine (dB A)	82		84	
Muffler (dB A)	76			
Operating pressure (psi)	80			
Voltage (V)	240		380	
Consumption (kW)	1.0	2.7 / 2.68	3.82 / 3.88	6.05/6.07
Amperage (A)	6.6	8.6	4.6	7.4
Weight (lb)	900	915	1100	1150
Warranty	1 year			

## HOW IT WORKS

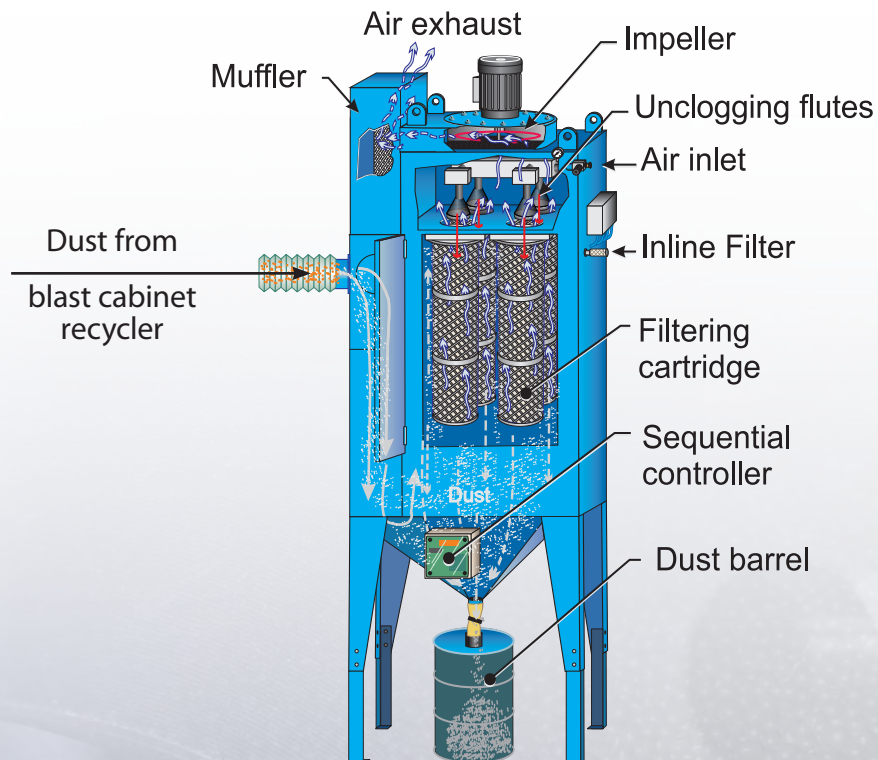

## GENERAL DESCRIPTION

The dust cleaning systems have cartridges, used to draw the abrasive suspended inside the cabinet or room.

The fan sucks air in from the recycler from 600 to 1800 cfm, depending on the size of the turbine and the engine. Dust and fine particles pass through the recycler and are retained by the dust and only clean air is rejected.

The cartridges are cleaned by a pulse of compressed air blowing the inside of it. The pulse reverses momentarily the flow of air passing through the cartridges and clearing the dust on the outer surface of the cartridges. The dust falls to the bottom of the barrel and dust recovery thereafter (page 17).

The interval of the pulses is controlled by a timer inside the control box. The timer control time function (duration of each pulse) and the stop time (downtime between each pulse). Time as a function should never be adjusted. The higher the setting time off, the lower the time in each pulse will be short.

**CAUTION :** Do not operate the system cleaning on new cartridges before they are sealed. Emit a pulse of non-sealed cartridges could cause premature failure of the cartridges or reduce the effectiveness of dust.

The differential pressure indicator shows the difference in pressure between the side coated with dust and clean the cartridges. The indicator helps determine the appropriate pressure and pulse time setting off. See page 16.

**BEFORE STARTING TO WORK** you must wear earing protections, efficient for 80 dB or more.

## ENVIRONMENTAL CONDITIONS FOR WHICH THE EQUIPMENT IS DESIGNED

- Indoor location
- Altitude 2 000 m max.
- Ambient temperature: 40 °C max.
- Relative humidity: 80 %
- Main supply voltage fluctuation +/-10 %
- To use with noncombustible dust only



## INSTALLATION

### **WARNING**

ALL ELECTRICAL CONNECTIONS TO THE ISTBLAST EQUIPMENT SHOULD BE MADE BY A QUALIFIED ELECTRICIAN AND MUST ADHERE TO THE CODES, STANDARDS, AND PROCEDURES SPECIFIED BY THE AUTHORITY HAVING JURISDICTION. THE CUSTOMER IS RESPONSIBLE FOR PROVIDING APPROPRIATE DISCONNECTING MEANS ADJACENT TO THE EQUIPMENT FOR EACH INCOMING POWER CIRCUIT..

### **CAUTION**

BEFORE PROCEEDING TO INSTALLATION, THE ELECTRIC POWER SUPPLY MUST BE LOCKED AND TAGGED. FAILURE TO COMPLY WITH THIS COULD RESULT IN SERIOUS INJURIES DUE TO ELECTRIC SHOCK..

1. The dust collector should be located on a leveled area near the back of the cabinet, while respecting the laws and regulations in your area. Allow access to components such as the pressure gauge, fan, door and hatch, the barrel, the cartridges and cleaning system.
2. Make sure the equipment is leveled, installed on a solid surface, and well grounded. Do not place on a wooden floor or a rubber mat, unless a ground wire has been installed. Check with a qualified electrician.
3. This dust collector requires an electrical connection. The electrical connections depend on the size and number of motor phases. Refer to the Electrical Drawings on pages **25 to 29**.
4. After the installation is complete, verify the direction of rotation of the turbine. To check the direction of rotation, turn on and turn off the engine quickly to provoke a slow rotation of the blades. Look inside the slots above the engine where the turbine can be readily observed. The right direction of rotation is indicated by an arrow. The impeller should rotate toward the blower.

If the rotation is not the same, please notify an electrician so that it performs the necessary change.

### **CAUTION**

NEVER LOOK INSIDE THE EXIT OF THE FAN WHEN THE FAN IS RUNNING. FAN EJECTED DEBRIS COULD CAUSE INJURY.



**GROUNDING:** To prevent static electricity from accumulation, connect the ground wire of the dust collector to a connection anchored to the factory ground.

5. Check the amperage on initial startup. If the engine uses too much amperage, gradually close the wall until the data meets the specified amperage of the motor plate. The partition is located at the fan outlet.

## INSTALLATION (CONT'D)



6. Connect one end of the tubular transport of abrasive at the exit of recycling ① and the other end at the entrance at the bottom of the scrubber ②. Secure each end of the hose with clamps included with the hose.

The wire is removed on the first 2 or 3 inches. Be careful not to damage the hose. The wire helps dissipate static electricity inside the hose. For the static is dissipated, each segment must be in contact with the metal of which must have a firm grounding installed.

7. Make sure the dust collecting drum is properly located under the dust collector and that it has been correctly secured to it.

8. Connect your shop's air supply line to the dust collector air inlet. Your air supply must be coupled to the air inlet with a **Quick-Connect coupling ③ for an inlet of ½" ball valve in order to compensate the air restriction. (see details page 10). Choose couplings that offer as little restriction to the airflow as possible.**

To properly operate, your IST system must use clean, dry air. Use proper filters, air dryers, and air purifying systems to ensure clean and dry air is supplied.

An isolating valve should be installed at the main source of air to depressurize the system for maintenance.

If you use a rigid conduit for your air duct, a flexible section must be installed to allow the opening of the door.

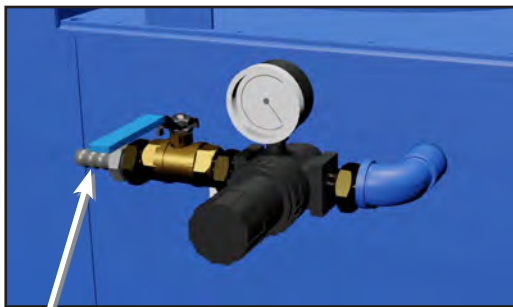

**IF YOU ARE USING INTERLOCKING CONNECTIONS, LIKE CHICAGO COUPLINGS, SECURE THEM WITH PINS. A CONNECTION THAT DISCONNECTS UNDER PRESSURE COULD CAUSE SERIOUS INJURY.**

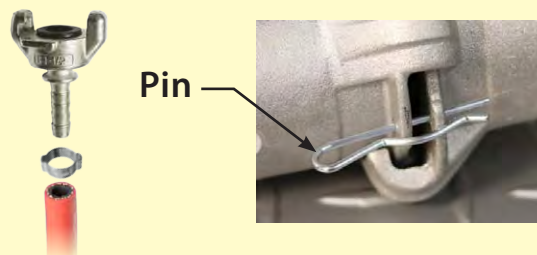



## OPERATION

**ATTENTION:** any person operating this equipment must be aware of the dangers related to sandblasting. Prolonged exposure to dust may cause severe lung damage or death. If you ingest toxic materials such as lead dust or dust from heavy metals or corrosives this may cause serious respiratory problems or death. Identify materials to be removed by sanding and get a data sheet of the abrasive used. If lead or other toxic material is removed by sanding, HEPA filter should be used.

### **Initial startup**

Before to start, the dust collector hatch and the drawer of the recycler must be closed when the scrubber is operating.

**WARNING:** *do not operate the cleaning system on new cartridges before they are clogged. Emit a pulse on unclogged cartridges could cause premature failure cartridges or reduce the efficiency of the dust collector. This initial clogging layer dust will allow cartridges to filter efficiently. It is for this reason that during the first hours of use, the filter elements of your dust collector will leave some dust escaping from the air outlet.*

### **Start-up operation**

Make sure the front access door is closed securely by using the pull handles and the recycler of the drawer is locked with latches. Make sure that the sequencer is running.

**NOTE: Do not start the cleaning system before the cartridges are pre-clogged.**

### **Shutdown**

- Let the dust vacuum particles suspended in the blast room fall down.
- Turn off the engine of the dust collector.
- Turn off lights extra.
- Close the air supply.
- Empty the dust by trapping in the dust collector or empty the dust collection barrel (See page 10).

## ADJUSTMENTS

### **Pressure Module**

The pressure regulator located at the entrance of the tank, adjust the pressure pulses. Adjust the pressure to 70 psi.

### **Automatic cleaning system**

Your dust collector is equipped with an automatic cleaning of the cartridges. A digital display will indicate the status of dirt cartridges, this indication is expressed on a scale of inches of water vacuum, this value will indicate the restriction (amounts of dust) on the cartridges. The electronic module will activate the cleaning cartridges as needed according to the schedule settings and cleaning will stop automatically when the cleaning is completed. If your dust collector is equipped with a HEPA option please ensure that preventive maintenance is performed to replace the filters on a regular basis, they could affect the amount of air cfm circuit and minimize the visibility for the operator blasting cabinet (HEPA system has no automatic cleaning system).

### **Programming automatic sequencer**

This module can be configured to achieve maximum efficiency of your cartridges, some parameters must be changed if required Please refer to the section: DCT1000 module on pages 32 to 49.

Use the keys (Select) and (Up) (Down) you will be able to change some parameter.

Note: Your unit has been programmed in the factory, if you change some settings be sure to write down the initial settings.

## DRAINING DUST

Remove dust from the barrel on a regular basis. Before opening the door, make sure you have a container under the trap to collect dust. If you are equipped with a barrel under your dust collection, open the lid and empty the barrel.

## CARTRIDGE DUST COLLECTOR - GENERAL PARTS LIST

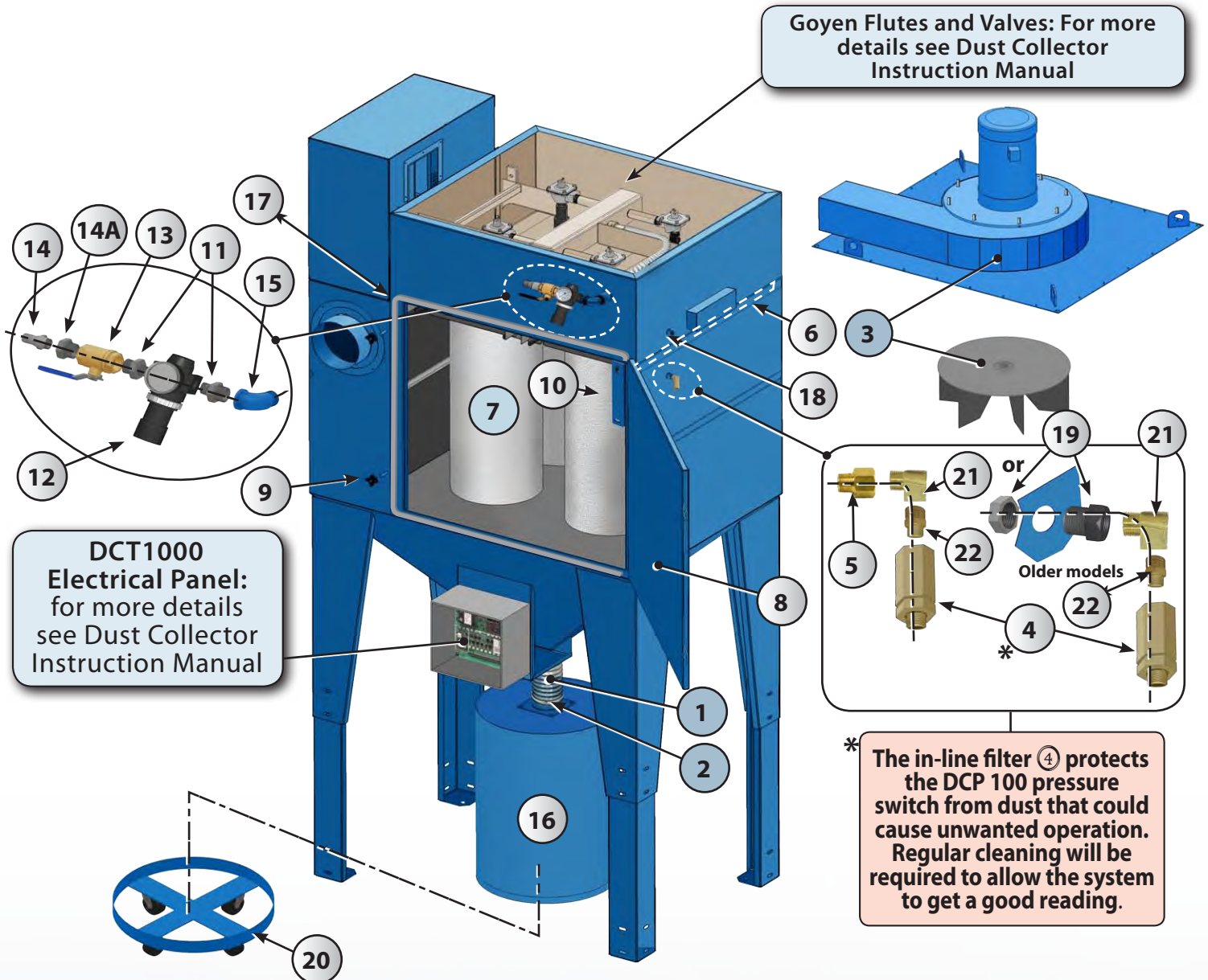

#	PART #	DESCRIPTION	#	PART #	DESCRIPTION
1		Hoses : see table page 35	13	608102	½" Ball Valve
2		Clamps : see table page 35	14	607222	¼"-¼" NPT Quick-Connect Fitting
3		Motor : see table page 35	14A	630351	½" @ ¼" MF Reducer
4	611058	⅛" Inline Filter	15	630641	1" MF @ 90° Elbow
5	632248	¼" @ ⅛" HEX. Reducer	16	901448	30 gal Collecting Barrel
6	NPN	Cartridge Guide	17	618321	« D » Type Rubber Seal (Sold by foot)
7		Filtering Cartridge : see table p. 35	18	324560	¼" NPT @ ¼" TU Push-in Fitting
8	NPN	Access Door	19	932004	¼" FF Bulkhead Fitting
9	940109	Star Knob	20	919325	Trolley for Barrel
10	NPN	Cartridge Lock Key	21	630125	¼" MF @ 90° Elbow
11	630651	1" @ ½" Reducer	22	630141	¼" @ ⅛" Reducer
12	608022	½" Complete Pressure Regulator			



## FAN MOTOR & SUCTION HOSE

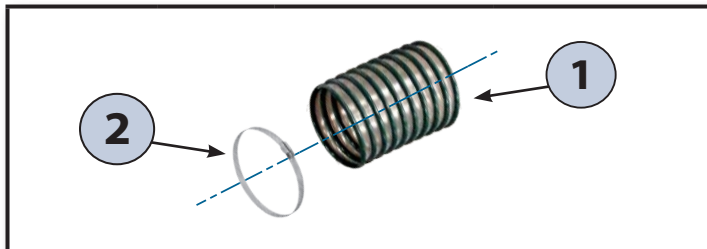

### BARBED SUCTION HOSES AND CLAMPS

Fan Motor (hp)	Hose I.D.	Hose (1)	Clamp (2)
1/2	5"	606168	624121
1	6"	606169	624124
2	7"	606171	624127
3	8"	606173	624128
5	10"	606177	624137

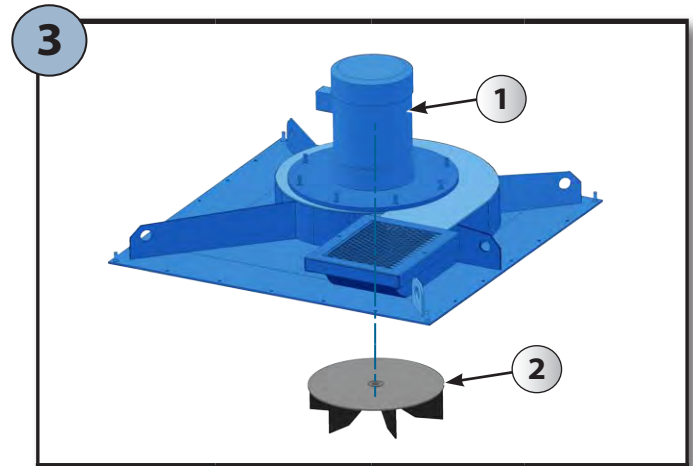

### FAN MOTOR

Power (hp) (1)	Voltages		Fan (2)
	240 V	380 V	
1/2	IST	S/O	610525
1	IST	S/O	610526
2	IST	S/O	610527
3	S/O	IST	610528
5	S/O	IST	610529
7.5	S/O	IST	IST
10	S/O	IST	IST



### FILTERING CARTRIDGES

#	STOCK	MODEL	NB.
(7)	901321	DCM600	2
		DCM900	
		DCM1200	4
		DCM1800	



## MUFFLERS

### STANDARD MUFFLER

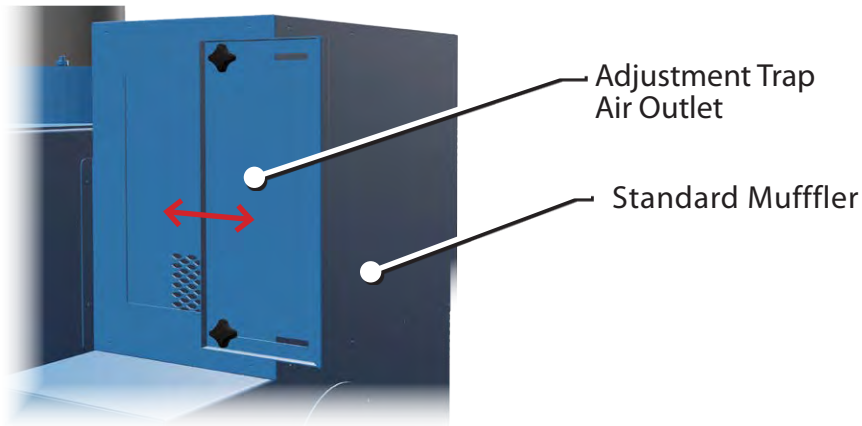

### OPTIONAL MUFFLER WITH UPGRADED MOTOR FAN

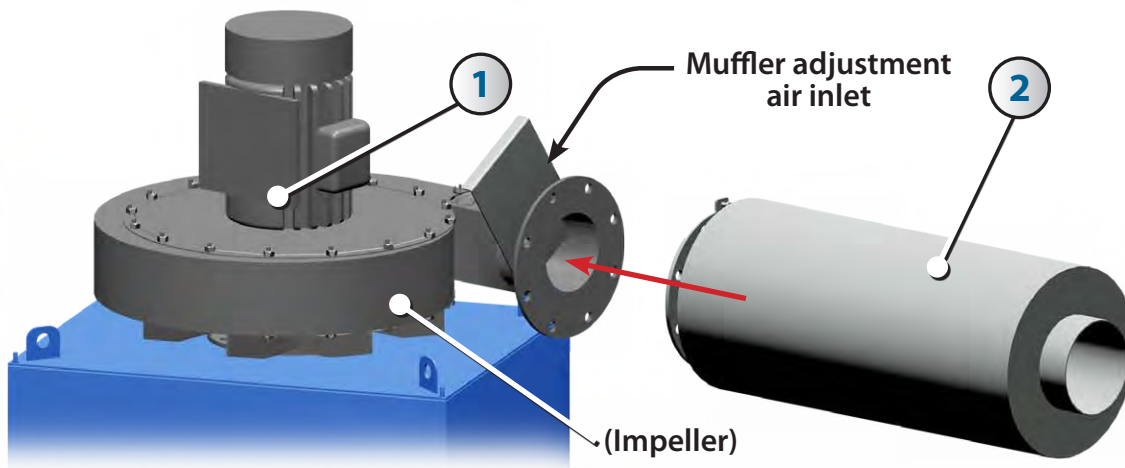

#### Muffler adjustment air inlet :

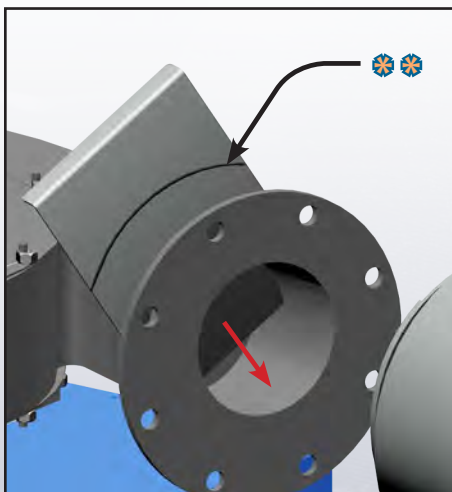

- It should be bolted directly to the output of the fan located on the dust collector. Make sure the exhaust gate valve is between the fan and the muffler. If required, adjust the gate valve to the **black mark** on the housing. ⚙️⚙️

⚙️⚙️ **Black mark** = *Factory calibration.*

ID	# STOCK	DESCRIPTION
1	916113	MOTOR 10 hp 600 V (C/W IMPELLER)
	916141	MOTOR 10 hp 460 V (C/W IMPELLER)
2	916086	HORIZONTAL MUFFLER 900 cfm

## DIAGRAMS (MOUNTING CARTRIDGES)

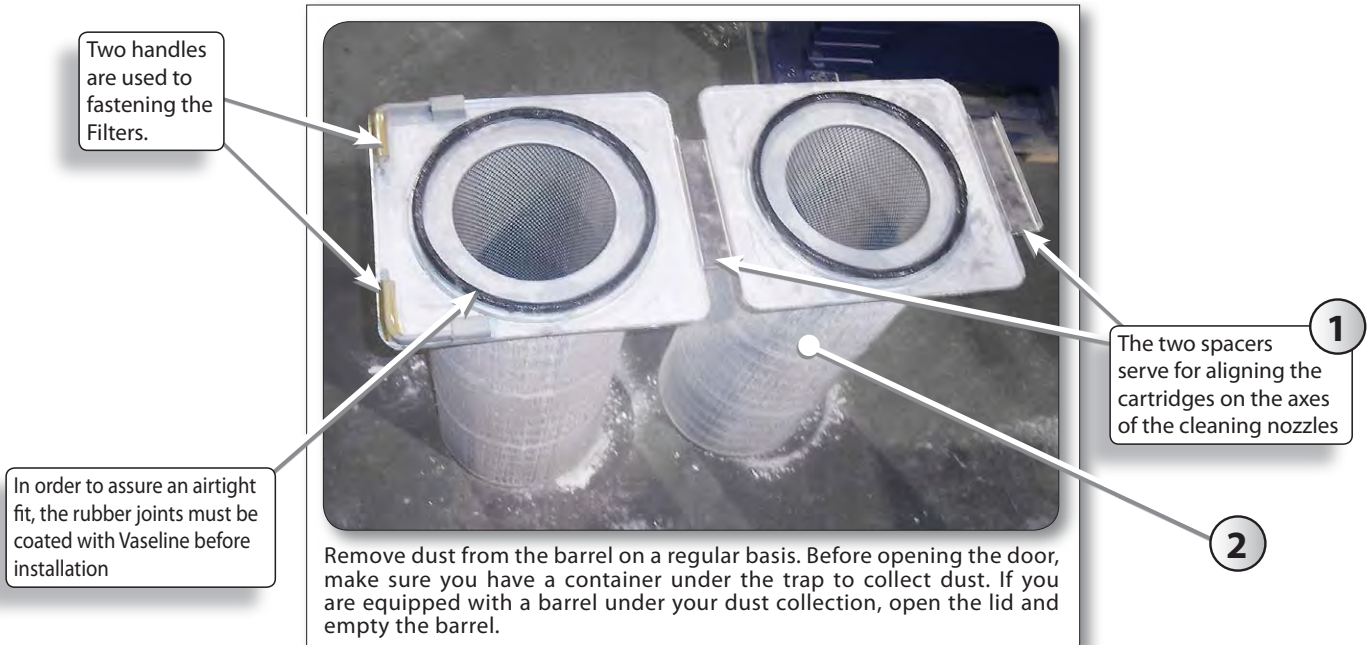

#	STOCK	DESCRIPTION
1	601301	SPACER*
2	901321	CARTRIDGE

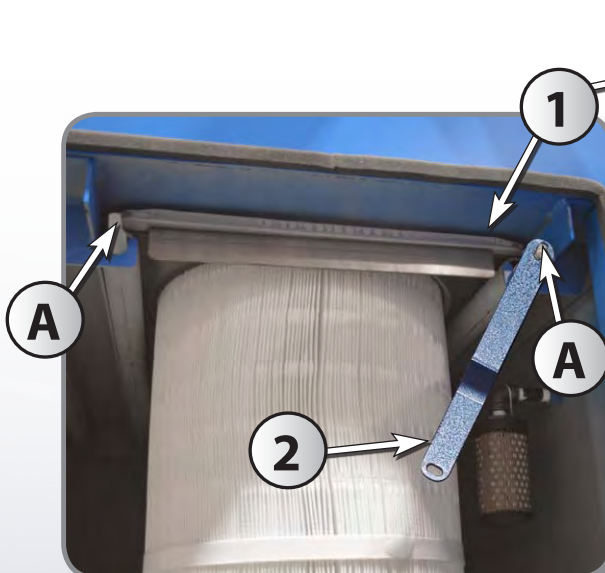

### When replacing the cartridge

- Put the spacer 1 on the top of the cartridge, with the arrows pointing to the back, insert the cartridge into the DCM above the two axes A, centered it then turn each axle a quarter turn clockwise to lock the cartridge in place.
- Repeat the same operation with the cartridge 2, 3 and 4 if necessary.

#	STOCK	DESCRIPTION
1	601301	SPACER*
2	NPN	CARTRIDGE LOCK HANDLE



## CARTRIDGE MEDIA



ISTblast cartridge-type dust collectors use pleated cartridge filter media made of cellulose and polyester blend. Nanofiber cartridge is also available for optional filtration efficiency.

Cartridge media provides exceptional filtration capacity, thanks to their unique pleat lock design that consists of a special folding process where a lock is pleated into the media allowing the entire filter surface to be available.

This technology also keeps the pleat evenly apart and prevents them from adhering to one another—which is particularly important if the process has any moisture during the application—, and allows for better release during the pulse cleaning process.

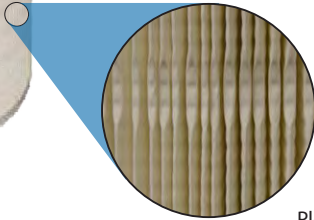

Pleat Lock Design

The cleaning process is controlled by the DCT1000 Dust Collector Timer Controller which triggers a series of reverse pulses inside the cartridge to release exceeding dust buildup on the surface.

### SPECIFICATIONS

Cartridge Type	Standard
Product No.	901321
Length	32"
Filter Area	248 sq.ft. of media
Pleat Count	280 pleats
Maximum Working Temperature	180 °F
Filtration Efficiency*	99.9% of particles down to 5 µm
MERV (Minimum Efficiency Reporting Value)	11
Air Permeability	15 cfm/sq.ft. @ 0.5" H <sub>2</sub> O
Flame Retardant	Optional

### CONSTRUCTION

Media Type	85/15 Media Cellulose Polyester Blend
Top Cap	Electro Galvanized
Bottom Cap	
Inner Core	
Outer Core	Two Polyester Bands

\* Filtration efficiency is provided for "seasoned cartridges" (when a dust layer is formed on its surface to achieve optimal filtration efficiency). Performance may vary according to the application.



**PREVENTIVE MAINTENANCE SCHEDULE**

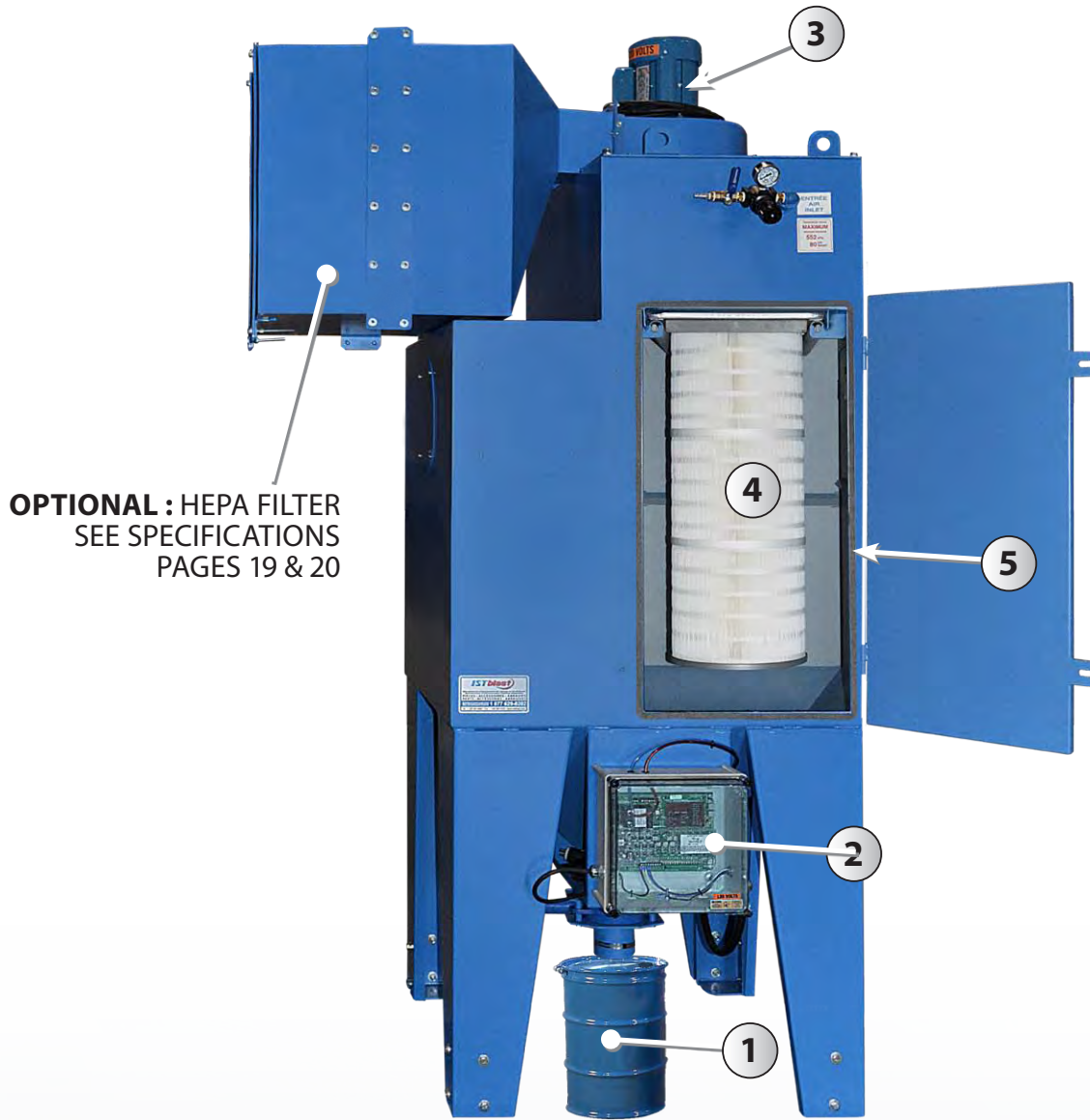

<b>DAILY MAINTENANCE &amp; OPERATION</b>	Recuperation drum ① : Check level every day and empty if needed
<b>WEEKLY MAINTENANCE</b>	Cartridges: Check for alarm signal and value displayed on the control panel ② Replace cartridges as needed ④
<b>MONTHLY MAINTENANCE</b>	Ducting: Check for leaks and wear, replace as needed
<b>BI-ANNUAL MAINTENANCE</b>	Motors ③ : Check motor bearing
<b>REPLACE WHEN NEEDED (ABOUT EVERY 3 YEARS))</b>	Cartridges ④ (each) # 901321
	Door seal ⑤ (1/2" x 1") (sold by foot) # 618305

# DCT1000 TIMER CONTROLLER - PERIODICAL ADJUSTMENTS

## HOW IT WORKS

### MONITORING OF PRESSURE DROPS

The DCT1000 monitors the static pressure differential between the clean and the dirty sides of cartridge filters – so-called pressure drop. As the filters load with dust, the resistance to air flow increases, and so does the pressure drop.

Brand new cartridge filter set will indicate a process value between **0.2 and 1.0**. During the first few hours of operation, dust will build up on the cartridges' pores in order to reach their optimal filtration capacities – this process is commonly referred to as the "dust cake".

Once the new cartridges are saturated with a dust layer, the normal operating value should be between **2 and 3.5** – which are the initial **Low Limit** and **High Limit** defined in the DCT1000.

**High limit : 3.5**  
**Low limit : 2.0**

### CARTRIDGE CLEANING

When the process value reaches the **High Limit**, the cleaning cycle starts emitting a series of pulses of air through each cartridge in order to dislodge exceeding amount of dust buildups. Pulses of air can be heard when the cycle is on.

During the cleaning cycle, the pressure drops should decrease on each pulse until it reaches the **Low Limit** which interrupts the cleaning cycle.

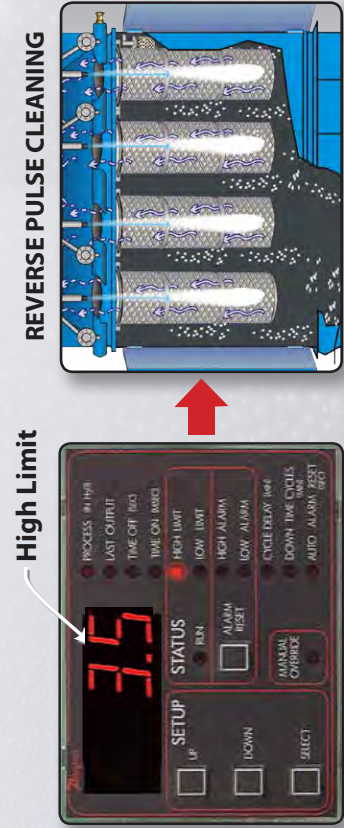
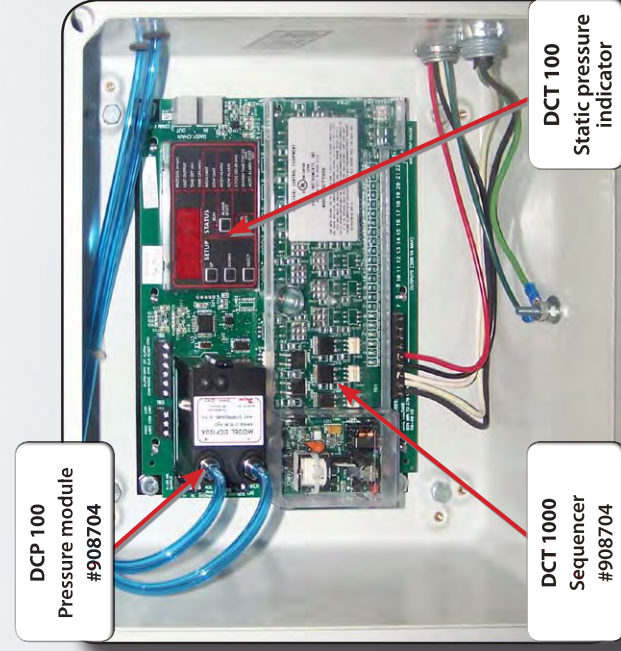
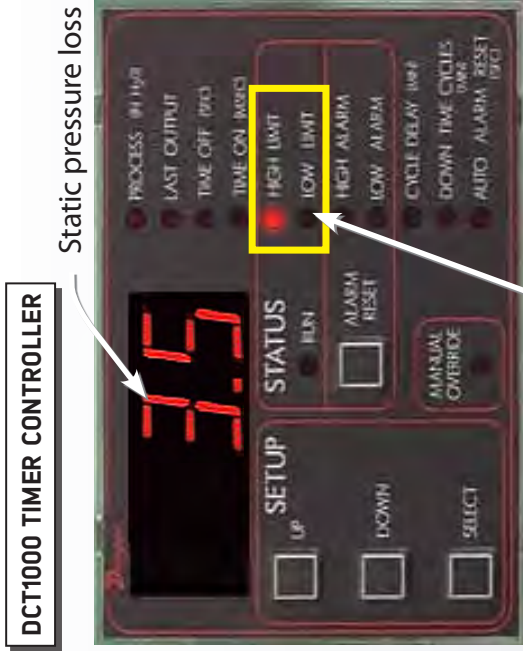



# DCT1000 TIMER CONTROLLER - PERIODICAL ADJUSTMENTS

## HOW IT WORKS

### INITIAL VALUES

High limit : 3.5  
Low limit : 2.0

Stagnant pressure drop



Follow the procedure below in order to extend the life span of your cartridge filters while maximizing the filtration capacity of your dust collector.

When the cleaning process of the cartridges is no longer able to reach the **Low Limit** value, the cleaning cycle will run continuously.

At that moment, it is advised to increase the **Low Limit** and **High Limit** in order to extend the life span of the cartridge media to a certain limit.

Start increasing the **Low Limit** and **High Limit** of the cleaning process by 2 decimals above the stagnant value. For example, if the cleaning cycle runs continuously and the process value on the DCT1000 indicates **2.2**, set the new **Low Limit to 2.4** and the new **High Limit to 3.9**.



### NEW VALUES

High limit : 3.9  
Low limit : 2.4



### NEED TO REPLACE CARTRIDGES

#### FINAL VALUES

High limit : 8.5  
Low limit : 7.0

Keep increasing moderately until your cartridges are incapable of reaching a **Low Limit of 7.0**. At that moment, it is time to change your cartridge filters and reset your process values to initial **Low Limit 2.0** and **High Limit 3.5**.

### REPLACEMENT OF CARTRIDGE FILTERS

Change all your cartridge filters at the same time, regardless of their individual condition.

If you notice a damaged cartridge, immediately replace all your cartridge filters at once – if a cartridge filter is damaged and/or perforated, it may cause severe damage to your impeller and mislead the DCT1000 timer controller in its ability to control the cartridges cleaning cycles properly.

**Refer to the owner's manual for parts number and changing procedure.**



# DCT1000 TIMER CONTROLLER

## ADJUSTMENTS

Use the keys (Select) and (Up) (Down) you will be able to change some parameter

Note: Your unit has been programmed in the factory, if you change some settings be sure to write down the initial settings



### SETTINGS

**Process:** Value displayed during operation of the fan (inches of water restriction cartridges)

**Last Output:** Number of active solenoid (this value can not be changed because the system auto-detects the number of active coil connected to the card)

**Time Off:** downtime between each pulse (value 10 seconds)

ON Time: Time pulse valves (value 250 milliseconds)

**High Limit:** The value to which the cleanup will begin (value between 2.5 and 3.5)

**Low limit:** The value to which the cleaning will stop automatically (value between 1.5 and 2.5)

**High Alarm:** Value must be reached to activate alarm (High limit value 2)

**Low Alarm: Value must be reached to activate alarm (value = 0)**

**Cycle Delay:** This value is to operate in manual mode (value = 0)

**Down time cycles:** This value is to operate in manual mode (value = 0)

**Auto Alarm reset:** This value is to operate in manual mode (value = 0)

## OPTIONAL HEPA FILTER - SPECIFICATIONS LIST

F	NOMINAL SIZE (inches)	ACTUAL (in.)			ACTUAL (mm)			AIRFLOW CAPACITY (cfm)	CAMFIL MODEL NUMBER
		H	W	D	H	W	D		
	12x12x1	11.50	11.50	292	292	350	054862-025		
	16x16x1	15.50	15.50	394	394	620	054862-012		
	20x10x1	19.50	9.50	495	241	485	054862-016		
	20x12x1	19.50	11.50	495	292	585	054862-019		
	20x14x1	19.50	13.50	495	343	680	054862-006		
	20x15x1	19.50	14.50	495	368	730	054862-008		
	20x16x1	19.50	15.50	495	394	780	054862-001		
	20x18x1	19.50	17.50	495	445	875	054862-020		
	20x20x1	19.50	19.50	495	495	970	054862-002		
	20x30x1	19.50	29.50	495	749	1460	054862-029		
	22x22x1	21.50	21.50	546	546	1175	054862-021		
	24x12x1	23.50	11.50	597	292	700	054862-022		
	24x14x1	23.50	13.50	597	343	815	054862-026		
	24x16x1	23.50	15.50	597	394	935	054862-015		
	24x18x1	23.50	17.50	597	445	1050	054862-028		
	24x20x1	23.50	19.50	597	495	1165	054862-011		
	24x24x1	23.50	23.50	597	597	1400	054862-005		
	25x10x1	24.50	9.50	622	241	610	054862-023		
	25x12x1	24.50	11.50	622	292	730	054862-024		
	25x14x1	24.50	13.50	622	343	850	054862-007		
	25x15x1	24.50	14.50	622	368	910	054862-013		
	25x16x1	24.50	15.50	622	394	970	054862-004		
	25x18x1	24.50	17.50	622	445	1095	054862-017		
	25x20x1	24.50	19.50	622	495	1215	054862-003		
	25x25x1	24.50	24.50	622	622	1520	054862-014		
	12x12x2	11.62	11.62	295	295	500	402314-001		
	16x16x2	15.50	15.50	394	394	890	049880-019		
	16x25x2	15.50	24.50	394	622	1390	049880-022		
	18x18x2	17.50	17.50	445	445	1125	049880-024		
	20x10x2	19.50	9.50	495	241	695	049880-008		
	20x12x2	19.50	11.50	495	292	835	049880-007		
	20x14x2	19.50	13.50	495	343	970	049880-009		
	20x15x2	19.50	14.50	495	368	1040	049880-011		
	20x16x2	19.50	15.50	495	394	1110	049880-001		
	20x18x2	19.50	17.50	495	445	1250	049880-013		
	20x20x2	19.50	19.50	495	495	1390	049880-002		
	20x24x2	19.50	23.50	495	597	1665	049880-023		
	20x25x2	19.50	24.50	495	622	1735	049880-021		
	20x30x2	19.50	29.50	495	749	2085	402271-007		
	24x12x2	23.38	11.38	594	289	1000	049880-006		
	24x16x2	23.50	15.50	597	394	1335	049880-016		
	24x18x2	23.50	17.50	597	445	1500	049880-015		
	24x20x2	23.50	19.50	597	495	1665	049880-012		
	24x24x2	23.38	23.38	594	594	2000	049880-005		
	25x14x2	24.50	13.50	622	343	1215	049880-010		
	25x15x2	24.50	14.50	622	368	1300	049880-020		
	25x16x2	24.50	15.50	622	394	1390	049880-004		
	25x18x2	24.50	17.50	622	445	1565	049880-014		
	25x20x2	24.50	19.50	622	495	1735	049880-003		
	25x25x2	24.50	24.50	622	622	2170	049880-018		

  

NOMINAL SIZE (inches)	ACTUAL (in.)			ACTUAL (mm)			AIRFLOW CAPACITY (cfm)	CAMFIL MODEL NUMBER
	H	W	D	H	W	D		
16x25x4	15.38	24.38	391	619	1390	059413-022		
20x16x4	19.38	15.38	492	391	1110	059413-004		
20x20x4	19.38	19.38	492	492	1390	059413-003		
20x24x4	19.38	23.38	492	594	1665	059413-023		
20x25x4	19.38	24.38	492	619	1735	059413-021		
24x12x4	23.38	11.38	594	289	1000	059413-002		
24x16x4	23.38	15.38	594	391	1335	059413-011		
24x18x4	23.38	17.38	594	441	1500	059413-009		
24x20x4	23.38	19.38	594	492	1665	059413-008		
24x24x4	23.38	23.38	594	594	2000	059413-001		
25x16x4	24.38	15.38	619	391	1390	059413-005		
25x20x4	24.38	19.38	619	492	1735	059413-006		
25x25x4	24.38	24.38	619	619	2170	059413-010		
25x29x4	24.38	28.38	619	721	2515	059413-007		

  



30/30



24x24x2

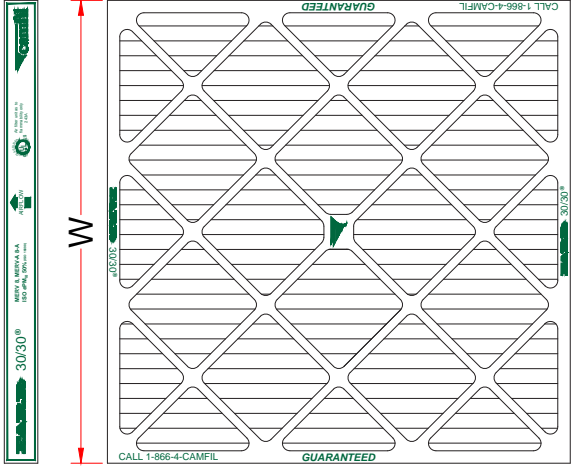

W, D

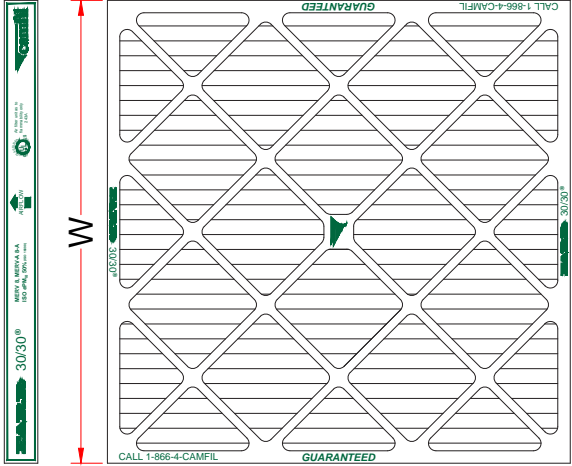

H, H

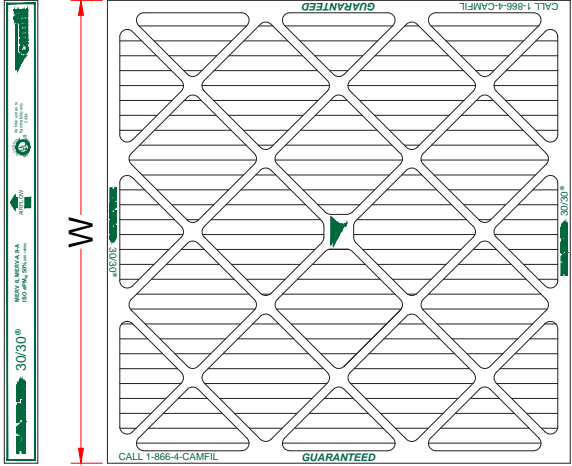

H, H

**GENERAL NOTES:**  
 1. MEDIUM EFFICIENCY, MERV 8 PANEL PLEATED DISPOSABLE FILTER. EFFICIENCY IS TESTED IN ACCORDANCE WITH ASHRAE 52.2-(LATEST REV). ALSO CLASSIFIED AS MERV-A 6+A PER APPENDIX J OF SAME STANDARD. PER ISO 16890, FILTER MEETS ISO ePM<sub>10</sub> 50% EFFICIENCY.  
 2. AVAILABLE SIZES (NOMINAL): SEE TABULATION BLOCK.  
 3. PERFORMANCE CHARACTERISTICS.  
 4. FILTER THICKNESS 'D':  
 1" NOMINAL = 0.88" ACTUAL  
 2" NOMINAL = 1.75" ACTUAL  
 4" NOMINAL = 3.75" ACTUAL  
 5. FILTER CLASSIFIED AS UL 900.  
 6. MAX OPERATING TEMP: 200°F (93°C)

**PERFORMANCE NOTES:**  
 1. SEE TABULATION BLOCK FOR AIRFLOW CAPACITY.  
 2. CAMFIL RECOMMENDS FILTER TO BE INSTALLED WITH THE PLEATS RUNNING VERTICALLY, PARALLEL TO HEIGHT DIMENSION.

AA	05/29/19	UPDATED ARTWORK AND SIZE AVAILABILITY	14016-UV	ACS	-	ACS
A	08/15/72	FIRST ISSUE	7660-N	-	-	-
REV	DATE	DESCRIPTION	END	DFT	CK	APP



Camfil USA, Inc. <http://www.camfil.com>

DESCRIPTION  
**FARR 30/30 FILTER**  
 0.88, 1.75, & 3.75 THICK

SHEET	DRAWING NUMBER	REV
1 OF 1	068766	AA

MFG. DWGS. 054862, 049880, & 059413







## CLOGGING SYSTEM

### DCM 600 & 900

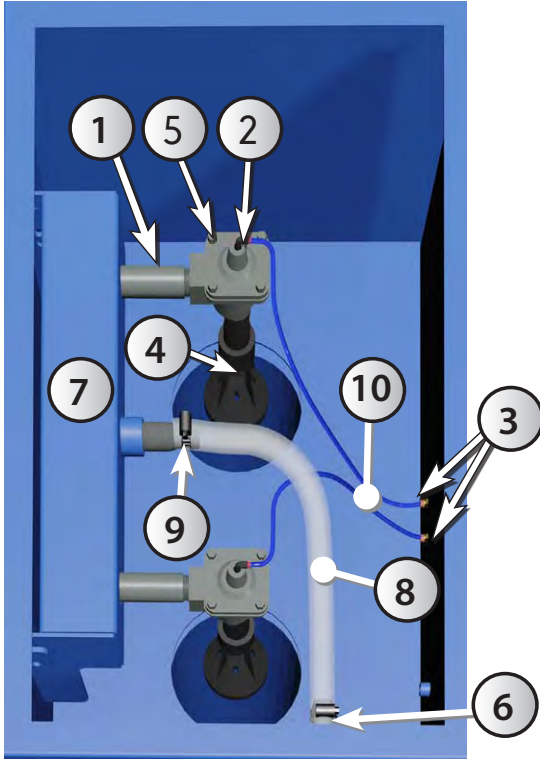

#	STOCK	DESCRIPTION
1	925016-56	PA NIPPLE 1" x 6"
2	324561	90° ¼" TUBE - ⅛" NPTM PUSH IN FITTING
3	324502	¼" PUSH IN BULKHEAD FITTING
4	908203	1" GOYEN CLEANING FLUTE
5	608353	1" GOYEN VALVE
6	630690	1" MPT HOSE BARB FITTING
7	925016-58	AIR MANIFOLD 4" X 4" X 1/8" THK.
8	606107	1" PVC HOSE 125 psi @ 70° F (SOLD BY FOOT)
9	624109	"T" CLIP #24 (1.06"-2")
10	324571	¼" BLUE POLY. TUBING (SOLD BY FOOT)

### DCM 1200 & 1800

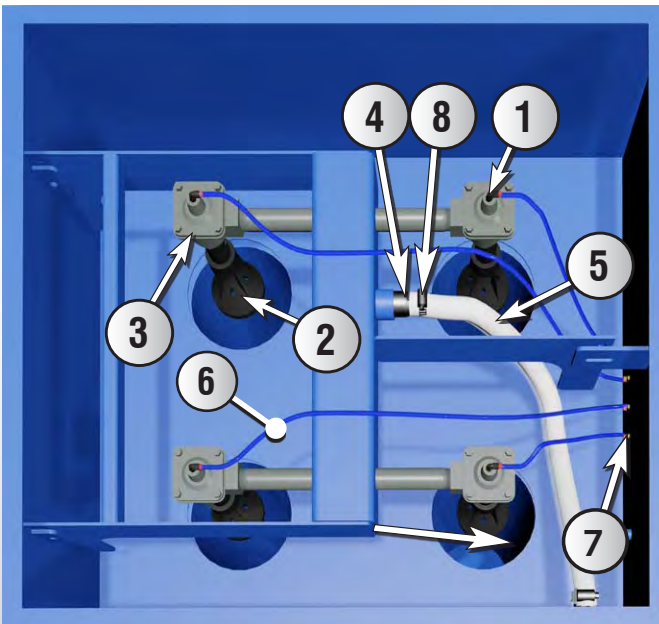

#	STOCK	DESCRIPTION
1	324561	90° PUSH IN FITTING ¼" tube- ⅛" NPTM
2	908203	CLEANING FLUTE
3	608353	1" « GOYEN » VALVE
4	630690	1" PA ADAPTER
5	606107	1" PVC HOSE - 125 psi @ 70°F (SOLD BY FOOT)
6	324571	¼" POLY. BLUE TUBING (SOLD BY FOOT)
7	324502	¼" PUSH IN BULKHEAD FITTING
8	624109	"T" CLIP #24 (1.06"-2")

## SOLENOID VALVES

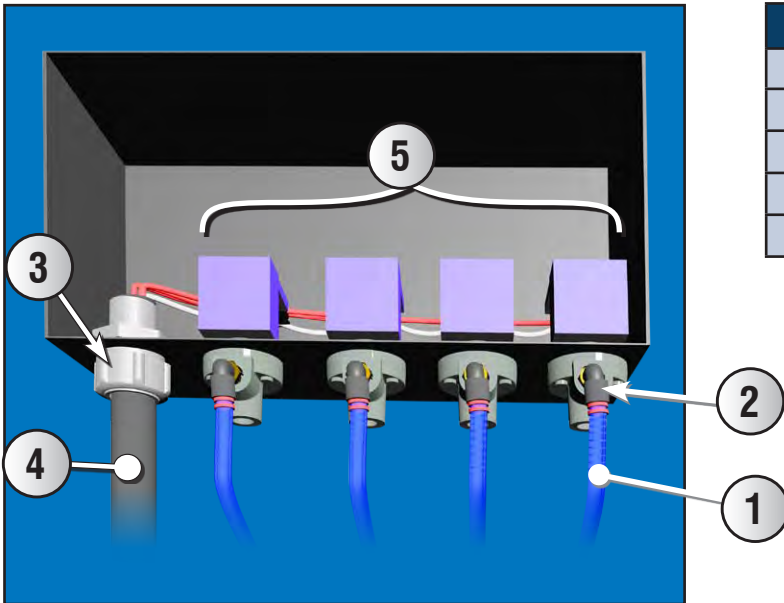

#	STOCK	DESCRIPTION
1	324571	1/4" BLUE POLY TUBING
2	324561	1/4" - 1/8" @ 90° PUSH IN FITTING
3	616770	3/8" STRAIGHT SEALED CONNECTOR
4	616535	3/8" WP CABLE (SOLD BY FOOT)
4	608572	1/8" 120 V GOYEN VALVE

## ELECTRICAL BOX

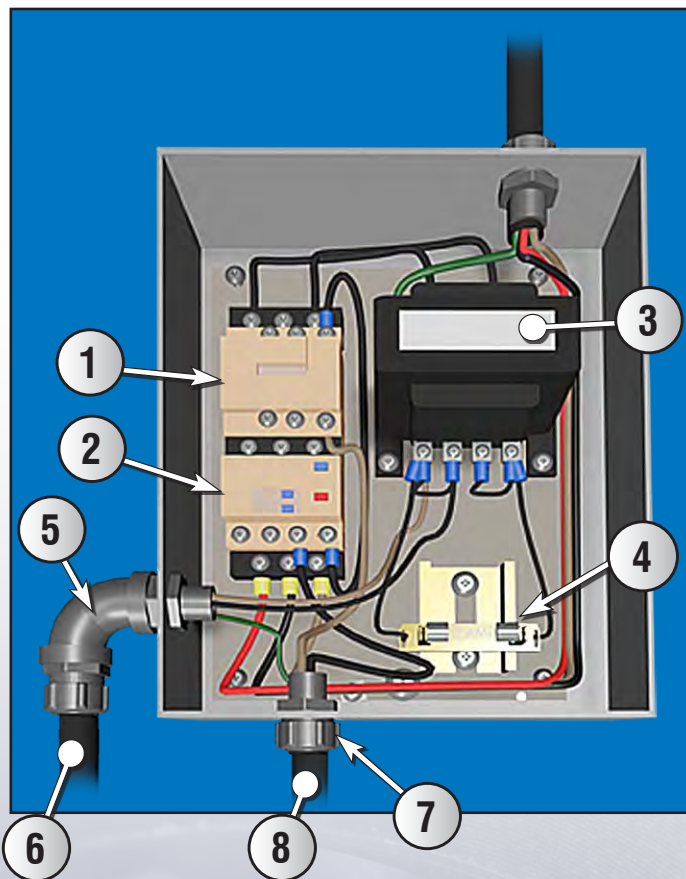

#	STOCK	DESCRIPTION
1	617063	7 1/2 hp MAGNETIC STARTER
2	617068	2.5-4 A OVERLOAD RELAY
3	917722	600/240 100 VA TRANSFORMER
4	616933	AGC 1 A - 250 V FUSE
5	616744	1/2" @ 90° #2269 .375/.500 WIRE CLAMP
6	616572	14-3 SJOOW FLEXIBLE CABLE
7	616741	1/2" #2522 (.375 A.500) WIRE CLAMP
8	616575	14-3 SOOW CABLE
9	324571	1/4" BLUE POLY TUBING (SOLD/FOOT)



**CAUTION** Turn off the dust immediately if dust escapes from the fan outlet. Make sure the cartridges are well placed and they are not damaged. If you breathe the dust or abrasive residue produced by the blast for a long time, you may suffer from severe respiratory illnesses. Ingestion of toxic dusts such as red lead poses an immediate risk to health. Identify the material removed by sanding and you pick the Material Safety Data Sheet of the abrasive used.

### TROUBLESHOOTING

TYPE OF FAILURE	POSSIBLE CAUSE	SOLUTION
<b>Impeller will not start.</b>	Power source electrical deficient	Check the fuses without the circuit.
<b>Abrasive is not sucked up and returned to the storage hopper.</b>	electrical connection inadequate	Check the rotation of the impeller.
	Blocked dust collector bags	Be sure to shake the dust collector bags well.
	Improper adjustment of the turbine outlet trap	Make sure that the hatch controlling the air evacuation flow at the outlet of the turbine is correctly positioned.
	Air leak	Make sure there are no leaks in the abrasive conveying ducts or hoses. Make sure the seal between the pressure vessel and the cyclonic separation system is tight.
<b>Ventilation system works but sanding does not work.</b>	A problem related to control of the pressure vessel	Refer to the pressure vessel manual in the troubleshooting section.
<b>The abrasive is found in large quantities in the dust collector.</b>	Too much feeding in secondary air	Look for an air leak between the pressure vessel and the storage hopper or cyclone system. Adjust the cyclonic system adjustment band. Adjust the impeller air exhaust trap.
<b>Large amount of dust in the right abrasive.</b>	Not enough alimentation in secondary air	Adjust the cyclonic system adjustment band.

### TROUBLESHOOTING (CONT'D)

TYPE OF FAILURE	POSSIBLE CAUSE	SOLUTION
<b>No pulse is generated</b>	Lack of compressed air supply	Check the pressure gauge, if the reading is low, check the adjustment of the regulator, air supply and check that no supply valve is closed.
	The DCT1000 Timer Controller is not powered	Check the electrical connexion on the DCT1000 Timer Controller. If not witness light is on, the system is not powered.
	The DCT1000 Timer Controller settings are altered	Verify the Min and Max values on the DCT1000 and compare with the reading. Check DCT1000 section for more details on the settings.
	A fuse has blown	Check the fuses in the electrical box. Replace if necessary.
<b>A cartridge is not pulsed</b>	The solenoids are defective	Check continuity of pulse and call IST if the number of pulses doesn't match the number of cartridges.
	One diaphragm valve is defective	Check the diagram of the valves. With the compressor off, inspect the valve diaphragms.
	The diagram valve's feeding tube is clogged	Inspect the diagram valves' feeding tubes and clean as necessary.
<b>There is a constant air stream rather than a pulse</b>	There is a leak between the hose valves and solenoid valves diaphragms	Check for a leak point on the dust collector's diaphragm valves assembly and replace hose as necessary.
	Solenoids remain open	Check continuity, clean and replace if necessary.



## **PREVENTIVE MAINTENANCE**

Always wear a properly fitted and maintained and goggles when cleaning the hopper tray. Failure to properly protect yourself, you may develop serious respiratory diseases and inherit your eyes. Toxicity and health risks vary by the type of abrasive and dust generated by sanding. Identify the material removed by sanding and you pick the Material Safety Data Sheet of the abrasive used.

### **WARNING**

**All maintenance must be done with the electric current turned off and locked label. The air supply must be closed, empty, locked and tagged. Failure to do this, you could be seriously injured following an electric shock to the activation of a component.**

## **REPLACEMENT CARTRIDGES**

Always wear a properly fitted and maintained and goggles when cleaning the hopper tray. Failure to properly protect yourself, you may develop serious respiratory disease and irritate your eyes. Toxicity and health risks vary by the type of abrasive and dust generated by sanding. Identify the material removed by sanding and you pick the Material Safety Data Sheet of the abrasive used.

1. Open the cartridge access door
2. Remove the cartridge from the front.
3. When the cartridges are removed, clean the inside of the dust collector.
4. Install the new cartridge as shown on page 13.
5. Inspect the seal of the front door, replace it if there are signs of damage.
6. Close the door and secure with grips.
7. Let the cartridges become clogged before using the cleaning system.

## **CLOGGING CARTRIDGES**

The new cartridges must be clogged. The cartridges clog, leaving a layer of dust accumulate on the surface there off. The layer of dust protects the cartridges and increases efficiency.

## **AUTOMATIC CLEANING CARTRIDGE**

Cleaning is done automatically. When the static pressure gauge indicates a high pressure alarm, high alarm signal is flashing. So cartridges must be changed.

**DCM 600 TO 1800 - PNEUMATIC DIAGRAM**

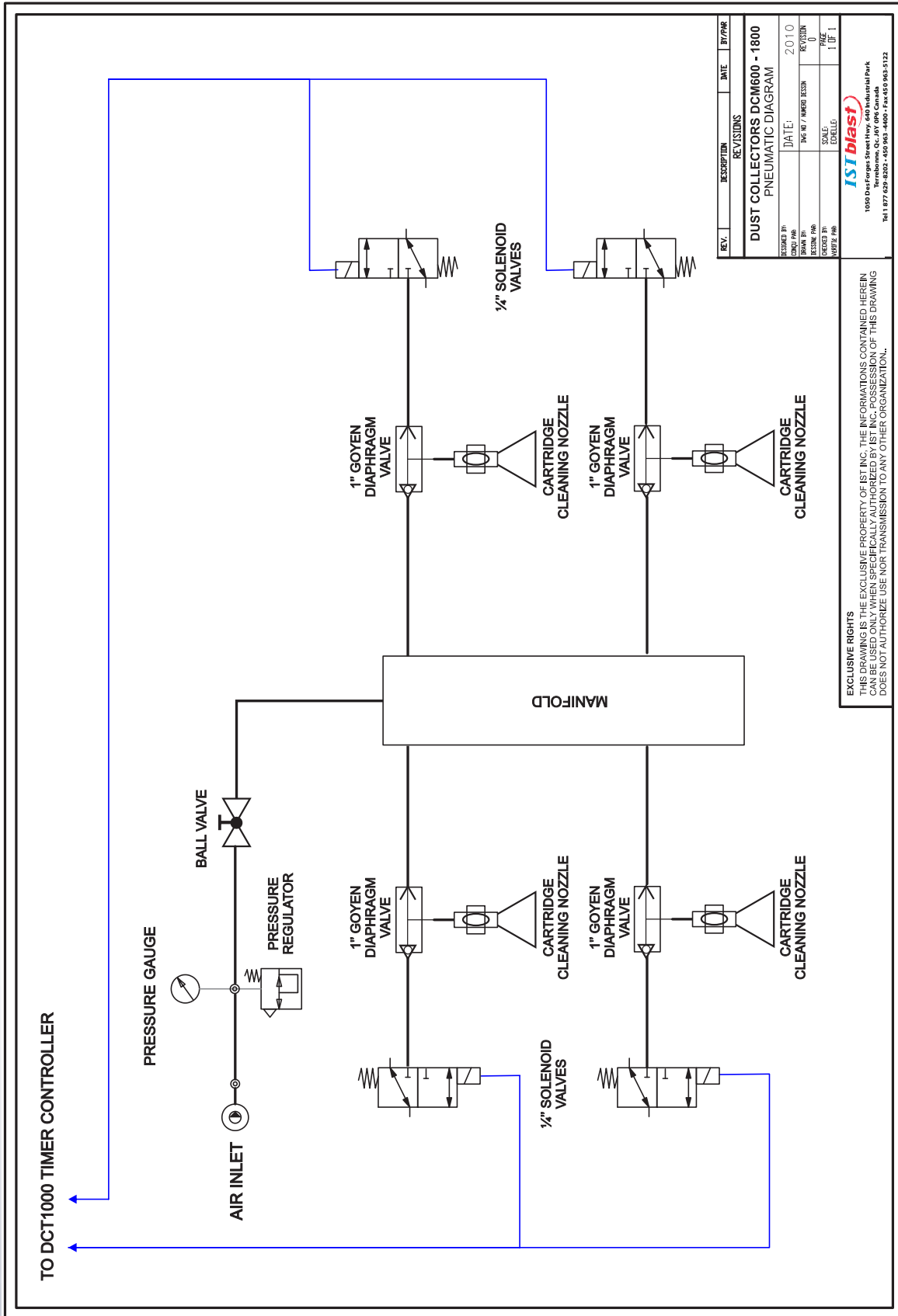



**ELECTRICAL SCHEMATIC FOR DCM 600 TO 1800 - 220 V / 1 PH - DIAGRAM**

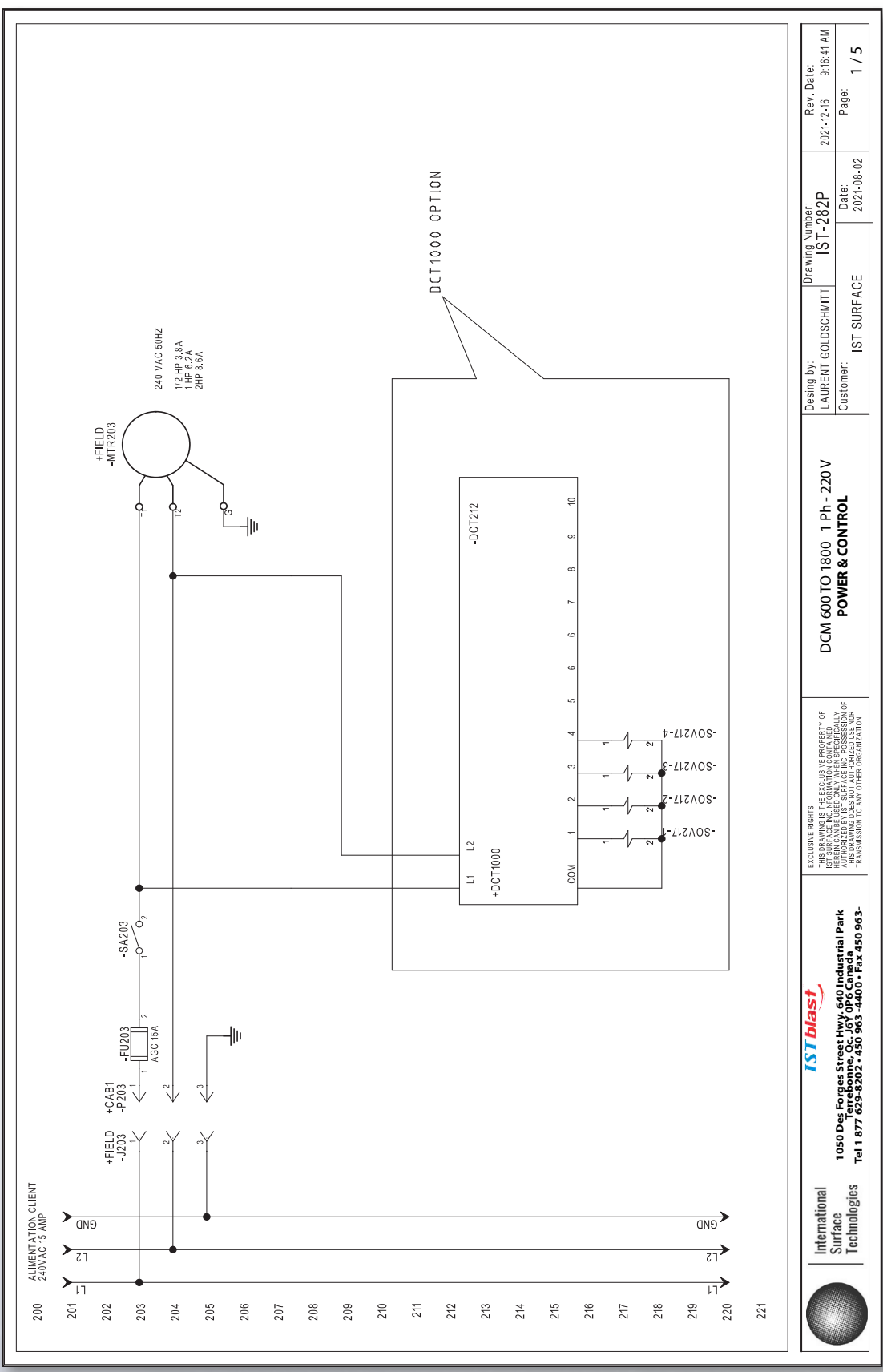

Desing by: LAURENT GOLDSCHMITT  
Customer: IST SURFACE

Drawing Number: IST-282P  
Date: 2021-08-02

DCM 600 TO 1800 1 Ph - 220 V  
POWER & CONTROL

EXCLUSIVE RIGHTS  
THIS DRAWING IS THE EXCLUSIVE PROPERTY OF  
ISTBLAST. IT IS NOT TO BE REPRODUCED,  
COPIED, OR TRANSMITTED IN ANY FORM OR  
BY ANY MEANS, ELECTRONIC OR MECHANICAL,  
INCLUDING PHOTOCOPYING, RECORDING, OR  
BY ANY INFORMATION STORAGE AND RETRIEVAL  
SYSTEM. THIS DRAWING DOES NOT AUTHORIZE  
TRANSMISSION TO ANY OTHER ORGANIZATION.

ISTblast  
1050 Des Forges Street Hwy. 640 Industrial Park  
TerraBonne, Qc. J6Y 0P6 Canada  
Tel 1 877 628-8202 - 450 963 -4400 - Fax 450 963-

International  
Surface  
Technologies



Rev. Date: 2021-12-16 9:16:41 AM  
Page: 1 / 5





**ELECTRICAL SCHEMATIC FOR DCM 600 TO 1800 - 380 V / 3 PH - DIAGRAM**

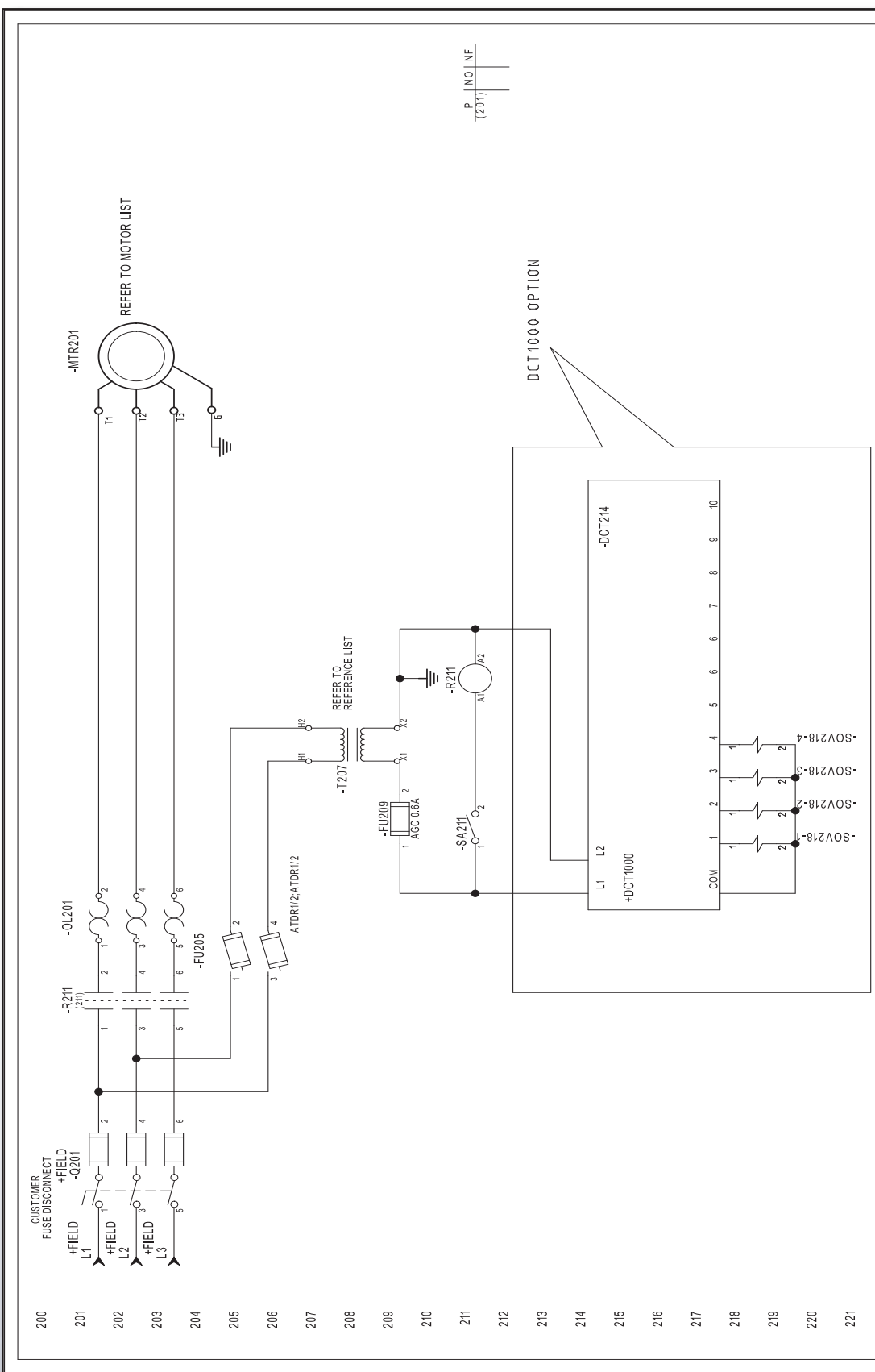

200  
201  
202  
203  
204  
205  
206  
207  
208  
209  
210  
211  
212  
213  
214  
215  
216  
217  
218  
219  
220  
221

<p>International Surface Technologies</p> <p>1050 Des Forges Street Hwy. 640 Industrial Park Terrebonne, Qc. J6Y 0P6 Canada Tel 1 877 629-8202 - 450 963 -4400 - Fax 450 963-</p>	<p>EXCLUSIVE RIGHTS</p> <p>THIS DRAWING IS THE EXCLUSIVE PROPERTY OF ISTBLAST. IT IS NOT TO BE REPRODUCED, COPIED, EITHER WHOLLY OR IN PART, OR TRANSMITTED IN ANY FORM OR BY ANY MEANS, WITHOUT THE WRITTEN PERMISSION OF ISTBLAST. ANY UNAUTHORIZED REPRODUCTION OR TRANSMISSION TO ANY OTHER ORGANIZATION IS STRICTLY PROHIBITED.</p>	<p>DCM 600 TO 1800 3 Ph - 380 V POWER &amp; CONTROL</p>	<p>Desing by: LAURENT GOLDSCHMITT Drawing Number: IST-282S Date: 2021-08-02</p>	<p>Rev. Date: 2021-12-03 09:26:34 Page: 3 / 5</p>
	<p>Customer: IST SURFACE</p>			





**ELECTRICAL SCHEMATIC FOR DCM 600 TO 1800 - REFERENCE LIST**

FOR EUROPE  
YOU MUST HAVE  
LADIMT220V AC COIL

MOTOR RATINGS VOLTS INPUT, STARTER AND OVERLOAD SELECTION								
POWER	VOLTS	AMPS	PHASES	HERTZ	RPM	STARTER	OVERLOAD	CUSTOMER FUSE TYPE AND CAPACITY
3HP	380V	4.6A	3	50	3000	LEDI093A62CG70	LRD10	AJT6
5HP	380V	7.4A	3	50	3000	LEDI093A62CG70	LRD14	AJT10
7.5HP	380V	10.6A	3	50	3000	LEDI093A62CG70	LRD21	AJT15
10HP	380V	14.5A	3	50	3000	LEDI093A62CG70	LRD22	AJT20

CONTROL TRANSFORMER SELECTION						
PRIMARY VOLTAGE	VA	PHASES	HERTZ	SECONDARY VOLTAGE	PART NO	PRIMARY FUSE
380VAC	100	1	50	240VAC	MTC100-31	0.5 amp

MOTOR RATINGS VOLTS INPUT AND SELECTION							
POWER	VOLTS	AMPS	PHASES	HERTZ	RPM	PARTS NO	MAKER
3HP	380V	4.6A	3	50	3450	NEP182TC2-2X4	NORDIC
5HP	380V	7.4A	3	50	3450	NEP184TC2-2X4	NORDIC
7.5HP	380V	10.6A	3	50	3450	NEP213TC2-2X4	NORDIC
10HP	380V	14.5A	3	50	3450	NEP215TC2-2X4	NORDIC

Desing by: LAURENT GOLDSCHMITT  
Customer: IST SURFACE  
Drawing Number: IST-282S  
Date: 2019-11-06  
Rev. Date: 2021-12-03 09:26:34  
Page: 5 / 5

DCM 600TO 1800 3 Ph - 380 V  
**REFERENCE LIST**

EXCLUSIVE RIGHTS: THE EXCLUSIVE PROPERTY OF IST SURFACE TECHNOLOGIES INC. IS HEREBY GRANTED TO THE USER OF THIS DOCUMENT. NO PART OF THIS DOCUMENT IS TO BE REPRODUCED OR TRANSMITTED IN ANY FORM OR BY ANY MEANS, WITHOUT THE WRITTEN PERMISSION OF IST SURFACE TECHNOLOGIES INC.

**ISTblast**  
1050 Des Forges Street Hwy. 640 Industrial Park  
Terrebonne, Qc J6Y 0P6 Canada  
Tel 1 877 629-8202 • 450 963-4400 • Fax 450 963-

International  
Surface  
Technologies



## SEQUENTIAL CONTROLLER

**DCP 100**  
Pressure module  
# 908704

**DCT 100**  
Static pressure  
indicator

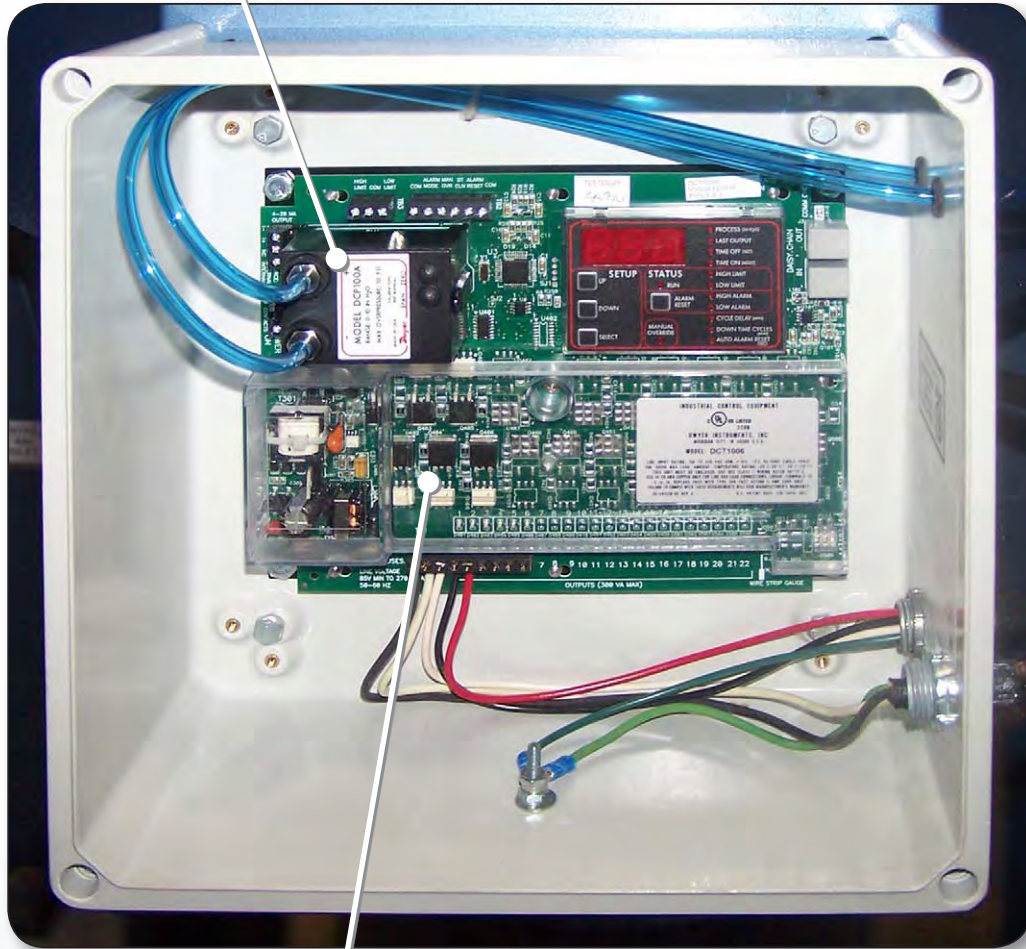

**DCT 1000**  
Sequencer  
# 908702

Sequential controller DCT-1000 dust collector used in conjunction with pressure module DCP 100  
Their operation is described in the documents attached pages 46 to 48.



## SEQUENTIAL CONTROLLER DCT1000 (SPECS)

### Specifications - Installation and Operating

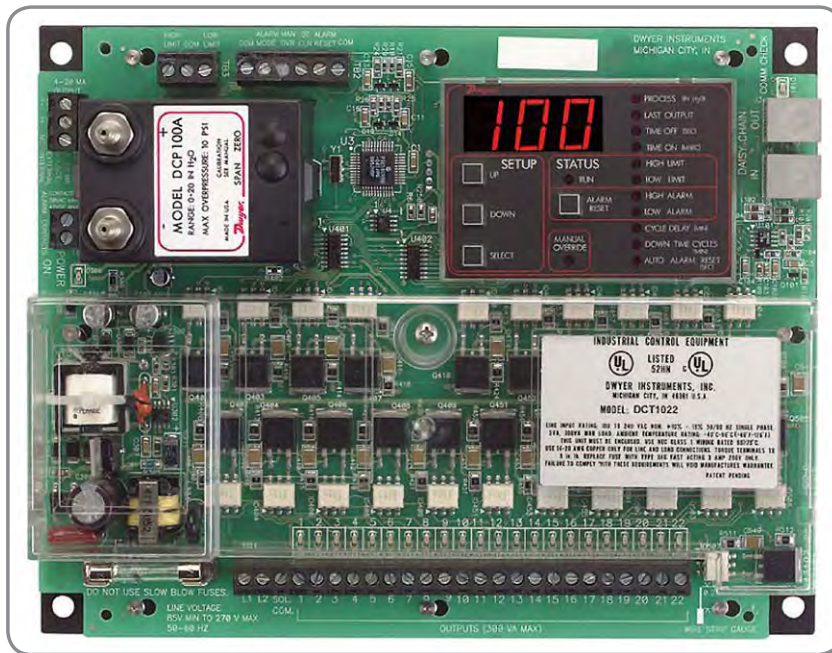

Thank you for purchasing the sequential controller DCT1000. You have selected a model of its kind in the field of controller that will provide years of operation with high reliability.

Sequential Controller DCT1000 has been designed for use with pulse jet type dust collectors for cleaning applications on demand or continuously.

The continuous cleaning applications require no external inputs and can be used depending on demand through the use of the functionality of cycle time.

For on-demand applications, the pressure modules (DCP100A/200A) optional can be used to enjoy all the features of DCT1000, or switch to external pressure (eg Dwyer Photohelic<sup>®</sup>) can be used to control high / low limit.

As with traditional Dwyer products, the Dwyer DCT1000 was designed so that it is easy to use, thus allowing for a quick and easy start up for your dust control applications. The contents inside this installation and operating manual will guide you through the features of the DCT1000 and how they can be applied to get the most out of your dust control requirements.

### SPECIFICATIONS

- Output Channels: 6, 10, & 22 channels. Expandable to 255
- channels using DCT1122 & DCT1110 channel expander boards.
- Power Requirements: 85 to 270 V AC, 50 or 60 Hz.
- Solenoid Supply: 3 A maximum per channel.
- Fuse: 3 A @ 250 V AC. Low voltage control circuitry is isolated from
- the line voltage for system safety.
- Temperature Limits: -40 to 140°F (-40 to 60°C).
- Storage Temperature Limits: -40 to 176°F (-40 to 80°C).
- On Time: 10 millisecc. to 600 millisecc. , 10 millisecc. by steps.
- On Time Accuracy: ±10 millisecc. .
- Off Time: 1 second to 255 seconds, 1 second steps.
- Off Time Accuracy: ±1% of the value or ±50 millisecc. , whichever is greater.
- Weight: 1 lb 3.0 oz (538.6 g).
- Agency Approvals: UL, cUL.

## SEQUENTIAL CONTROLLER (SPECS & INSTALLATION)

### dimensions and size

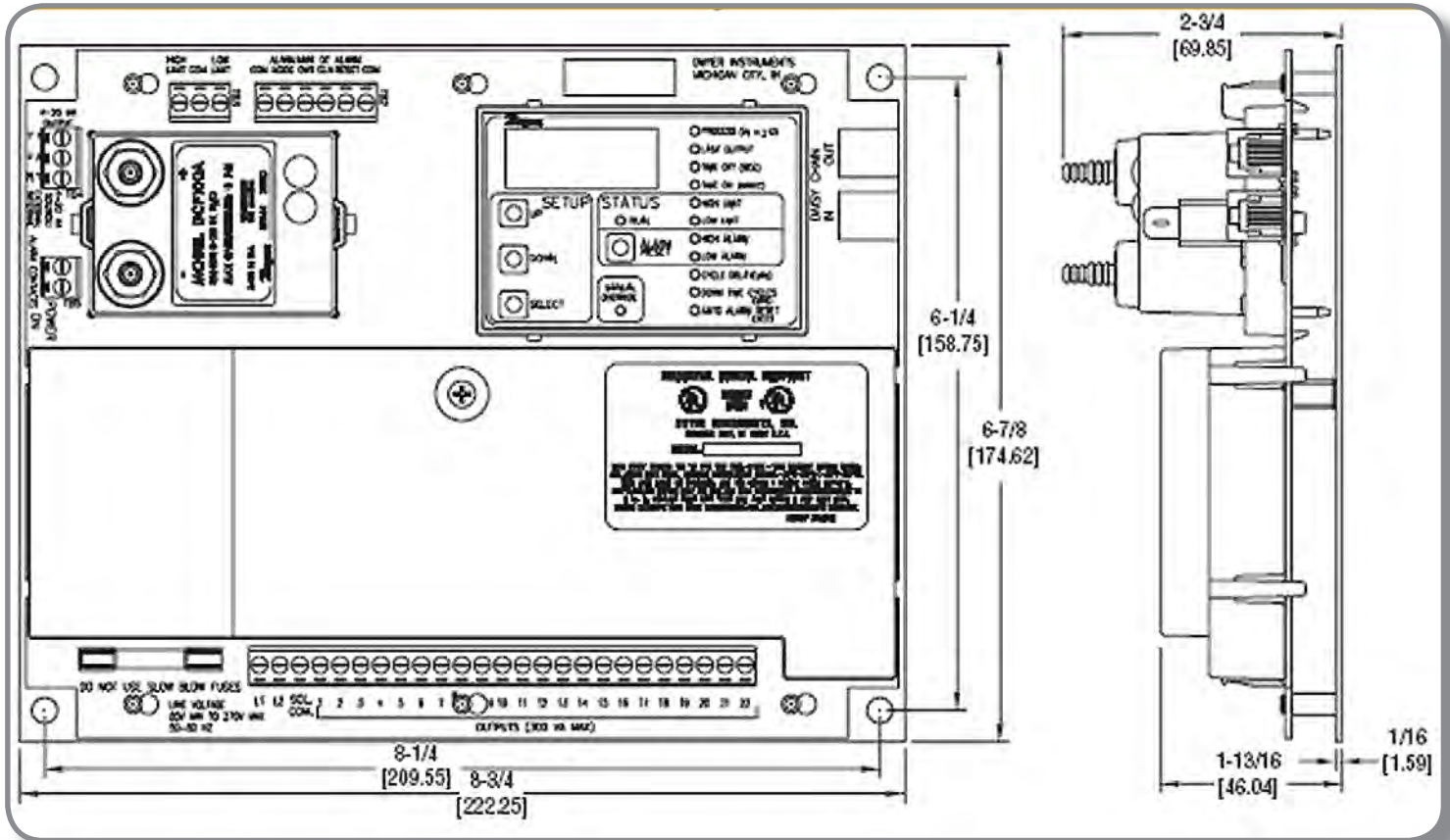

### 1.0 — INSTALLING THE DCT1000



**CAUTION:** Always install and maintain this device when the device is turned off and with a locking installed if necessary. Voltage line will be exposed naked in the output connector / power and the fuse. For this reason, we installed a protective plastic to protect the user from accidental contact with the exposed part.

Please note that the protective cover supply is a safety device and should be removed for any reason. For ease of installation and maintenance, connectors and fuses were left unprotected. The design of the open framework of the DCT1000 requires an enclosure that meets the appropriate safety and local code requirements. For optimal performance, the enclosure must also protect the controller from dirt, water and direct sunlight. There are no special requirements for orientation, and the controller is easily mounted using the mounting holes on the base plate factory installed.



**CAUTION:** Do not place the control cables, communication cables, or other Class 2 wiring in the same conduit as power cables. There may be a system malfunction if the Class 2 wiring is placed too close or with the power conductors



## 1.0 — INSTALLING THE DCT1000 (CONT'D)

### 1.1 — Requirements for feeding matter

The controller has a power «universal» power that connects input power of 120 V AC to 240 V AC. The input voltage must be between 85 and 270 V AC / 50 Hz or 60 No change in circuit is required when switching between these tensions. The values of solenoid, however, must be adjusted to accommodate the voltage of the selected line.

### 1.2 — Terminal connections of the DCT1000

Line solenoid valve and connections are located on the lower edge of the map below the plastic. The terminal block is a connector type «Euro» that grips the wire into the connector body. The connector accepts wires from 14 to 22 AWG. The wire should not be stripped of more than 0.25 inches to avoid short circuit or expose bare son creating a potential hazard of electric shock.

To help you determine the right to bare wire lengthways required a mark length of wire stripper is provided in the lower right corner of the map. The connector system used on the DCT1000 is specified for a single connection, but you can splice several together if local codes permit and that the practices of performance are met.

To power the master controller and extensionner dr channels, the supply must be connected to line L1 and L2 (see dimensional specifications, Figure 1). Connect the solenoid between the selected output and the common solenoids. The common solenoid and L2 are connected internally.

The contacts of the switches connected to the control inputs at the top of the table above should be isolated and only connected to the appropriate terminal and common terminals.

The following sections describe connections to external switch. See Figure 2 for the connection of the switch.

#### 1.2.1 Connection of external pressure

The controller can be used with a limit switch or external pressure sensor to provide the cleaning process the request. The high limit and low limit inputs can be used for this purpose. A simple on-off can be established with a single pressure switch connected to the input of the upper limit. Better control can be achieved with a limit gauge high and low as the Photohelic Dwyer<sup>®</sup>. In this mode of application, time, free time, and the delay of the cycle can be programmed to set the cleaning cycle. A three-pin terminal block (TB3) to connect the outside running up and down (see Figure 2 on next page). These switches should be isolated from contacts. The common line should not be grounded or protective equipment on the ground because they can introduce electrical noise and cause a malfunction or possible damage to the sequencer. The operations of these entries are as follows (see next page):

Operation in progress	Switch lower limit	Switch upper limit	Next operation
Waiting	Open	Open	Waiting
Waiting or pending	X	Closed	In progress
Waiting	∅	Open	Waiting
Waiting	Closed	∅	In progress
Run	Closed	*	In progress
Hold	Closed	∅	In progress

Legend	
X	Is open or closed
∅	Transition from open to closed
*	Transition from closed to open

## 1.0 — INSTALLING THE DCT1000 (CONT'D)

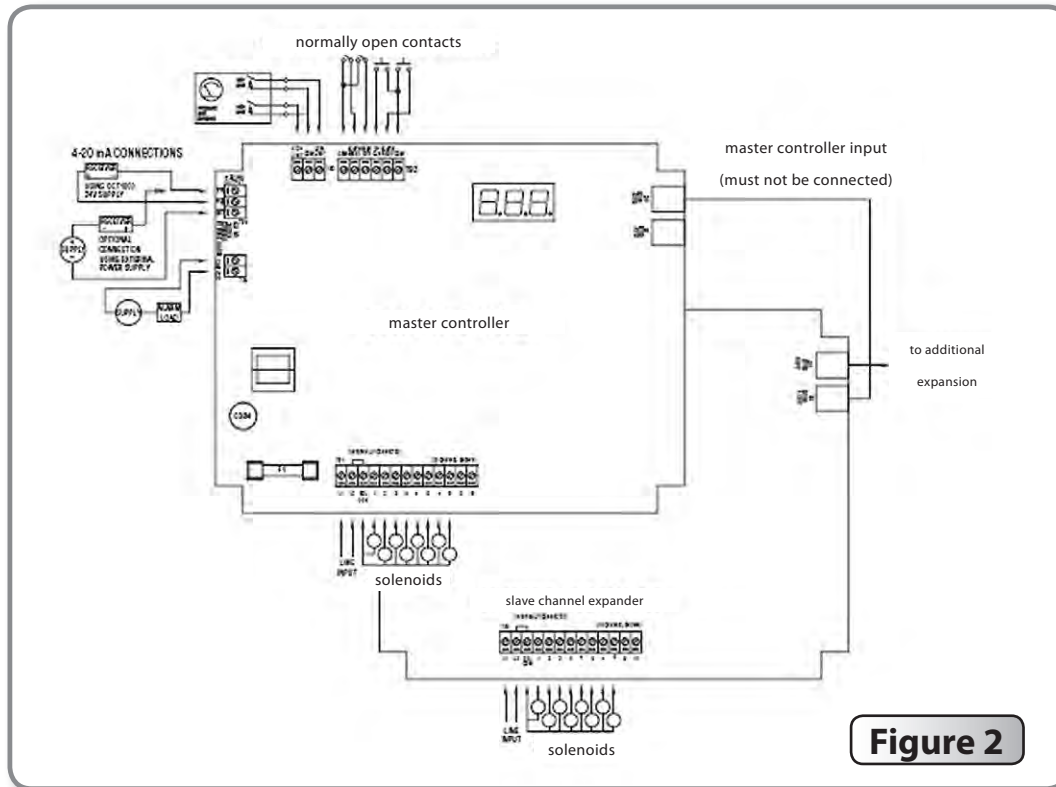

**Figure 2**

### 1.2.2 Connection manually override switch

The function manual control allows the system to be put to execution mode regardless of other conditions. This mode is activated when the terminal of the manual control and joint related. It is disabled when they are disconnected. If the controller is to operate in continuous mode, a jumper can be connected to these terminals. When manual control is required on a periodic basis, install a SPST toggle switch between the manual control terminal and the common terminal.

### 1.2.3 Timing for cleaning cycle

The timing for cleaning cycle power down time cleaning system realize an execution cycle for a period of time between 0 and 255 minutes. The operation is initiated by connecting the terminal time scale of a common terminal. This function is optimized by the use of an external switch normally open.

### 1.2.4 Connecting multiple tables timer

The two control panels master and slave can have up to 22 channels each. The system can be expanded up to 255 channels using master and slave controller cards. The DCT1000 will automatically detect the total number of channels involved and make their outputs available. You will notice that both master and slave controllers have a telephone-type connector mounted on the upper right side of the table. These connectors are used in systems require that tables be slaves chained in series to provide an additional channel capacity. For systems that require tables slaves, the master controller should have no connection made its entry into string unless it is designated as a slave control himself. (For systems requiring more than three cards slaves, a master controller to be used as slave board to meet the fourth power. This sequence is repeated until the limit of 255 channels has been reached. The cables do are not traditional telephone style cables.

## 1.0 — INSTALLING THE DCT1000 (CONT'D)



**WARNING :** Do not use jumper cables telephone. They have a cross connection and can damage controllers. Cables designed for use with the DCT1000 are available from Dwyer Instruments (Model-2 DCAC02 2 feet measure, then measure DCAC04 4 feet, etc.).

### 1.2.5 Mode in a continuous cycle

The master controller has several operating modes available for different applications. Starting with the basic mode, it is capable of operating with a continuous cleaning cycle. It can be initialized by placing a jumper between the input and the common limit High or by omitting the manual entry of the connection of the ordinary. The management of this cycle has three installation parameters: timing off, on time and cycle. The timing off the solenoid operates specifically on the schedule and the time interval between the end of impulsion and early the next. The delay of a delay cycle allows to program up to 255 minutes between the end of a complete cleaning cycle and the beginning of the next. This allows additional options to define a clean profile.

### 1.3 DCP Installation



**WARNING :** Before installing please go DCP100A/200A Please carefully review the terms of the operations specifications. Some operating systems, especially in applications of pneumatic transmission, may be that the static pressure or suction have conditions that exceed the capacity of the module pressure DCP100A/200A.

For these conditions, there are a number of additional products Dwyer pressure that can be used to meet your application requirements, all of which can be forwarded to the Controller Timer Dwyer DCT1000 Dust. For more information on these products and Dwyer, please call them at 219879-8000 or visit them on the web at : [www.dwyerinst.com](http://www.dwyerinst.com)-or-[www.dustcontrols.com](http://www.dustcontrols.com) .



## 1.0 — DCT1000 INSTALLATION (SUITE)

### 1.3.1 Location

The system should be located in an enclosure that meets appropriate standards of safety and electrical codes. There is no other requirement for the particular orientation as pressure module and the orientation is not critical. The path of the air piping should be particularly studied to ensure that there is no potential condensation or moisture that flows through the sensor. Where there is a high concentration of condensation present, a gutter or inlet filter should be installed to ensure proper operation in the long term.

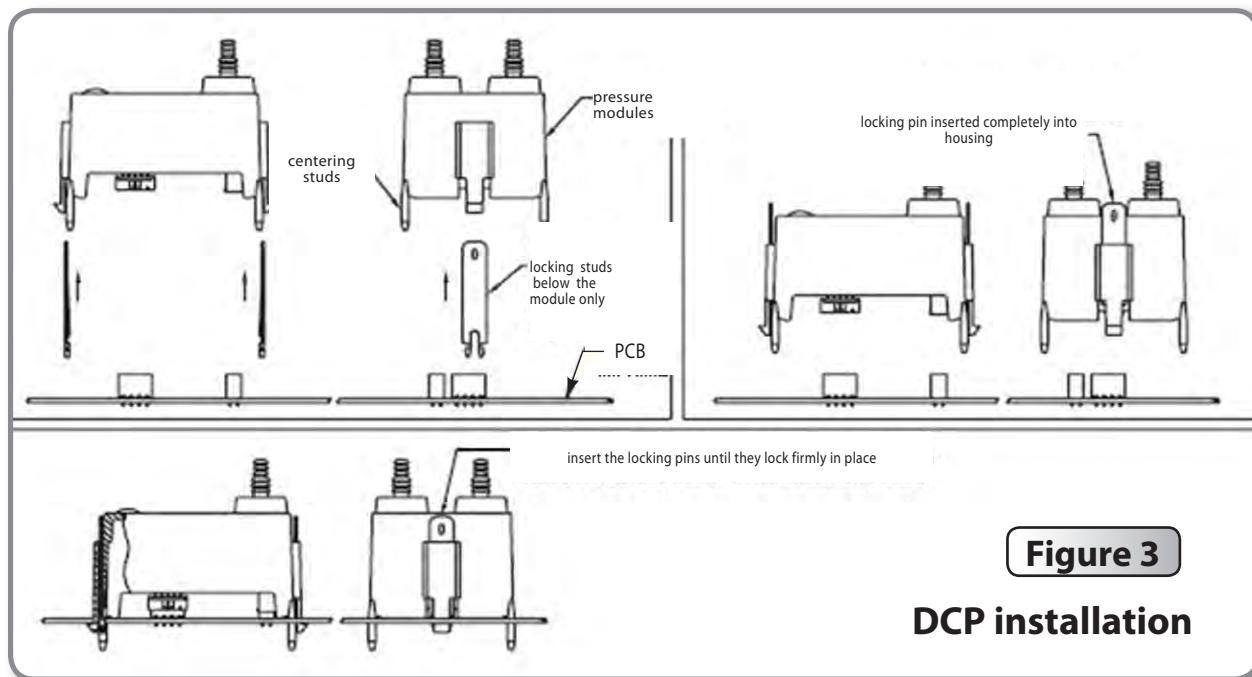

### 1.3.2 DCP connection to the master controller

The pressure module is attached to the master controller using integrated connectors on both units. Ports for the insertion pressure module are located in the upper left quadrant of the master controller DCT1000. The pressure module can be removed by compressing attachments retained each side of the module, then gently remove the module from the master controller circuit. By inserting the module, the following procedure should be observed to ensure proper installation:

- Examine the bottom of the pressure module and note the orientation of the connectors.
- Align the module so that the connectors match the connector receptacles on the circuit of the controller.
- Orient the module with the four blocks of alignment with their respective mounting holes.
- Gently press the module into the connector and slide the retaining clips on each side of the module in their homes.
- Always install and maintain this system with the power off and install a lock if necessary. Connect the pressure module to «Hot» in a system to damage the system or cause the cancellation of the calibration parameters.

By installing or removing the module and ensure to guide the module correctly with the table. Installing or removing the module from any angle can break the alignment pins.

## 1.0 — INSTALLING THE DCT1000 (CONT'D)

### 1.3.3 — Locking studs on model pressure

The DCP100A DCP200A and are provided with locking studs to secure the module. In normal operation, they are not necessary since the clips are sufficient to secure the module even in a high vibration. However, if the device must be delivered or used in conditions where strong mechanical shock could occur, the pins lock will ensure that the module does not break into standing out is its support.

To install the locking pin, insert a module below the plot behind each of the two brackets. The entire insert in the slot. The ends of the studs will depart through the slots at the top of this housing. Next, insert the module into the panel as shown above, making sure it is properly aligned and that is in place. Press the locking tabs exposed until the tab is pushed in behind the lock in the table. To remove the module, slide the locking tabs into place using a small screwdriver and remove the module as described above. See Figure 3.

### 1.3.4 — Connections of the DCP

When a pressure module is installed, the 4-20 mA process signal and alarm relay contacts are available. The 4-20 mA circuit is isolated from ground and other signals. The alarm relay contacts are isolated, normally open contacts. The pressure connections can be made with grooved couplings with hose is 1 / 8 " or 3 / 16 " dia. inside.



**Warning: Do not force the module into the connectors. Insertion force can damage the connectors. Properly aligned, the module clicks into place.**

### 1.3.5 — Maintenance of DCP

The pressure module should require very little maintenance in normal operation. However, a periodic calibration may be desirable to ensure accurate readings. The module can be removed and returned to the factory for calibration.

## 1.4 — Switch connection mode alarm

The automatic alarm reset is controlled by the mode switch for connecting alarm. To enable automatic alarm reset mode of alarm input to be connected to a common connection. A jumper can be used when the automatic reset alarm is still active. A switch can be used if there are times when stopping the automatic alarm should be disabled. The switch must be a single contact and wired, so no connection is made between one or the other son and the earth. See Figure 2 connections.

### 1.4.1 — Reset connection mode alarm

The alarm can be reset by pressing the reset button on the alarm control panel or by an external switch connected between the terminal alarm reset and common terminals. The alarm reset only works if the pressure module is installed and the pressure returned to normal. See Figure 2 connections.

### 1.4.2 — Connecting the 4-20 mA loop

The pressure module provides an isolated 4-20 mA output, which may be used to remotely monitor the differential pressure across the dust bags or cartridges. The connection is made on the master control module at the terminal block designated for this signal. The connection is a 2-wire configuration with the option of using either an external 15 to 35 V DC power source or using the internal 24 V DC source. See Figure 2 Wiring Connections.



## 1.0 — INSTALLING THE DCT1000 (CONT'D)

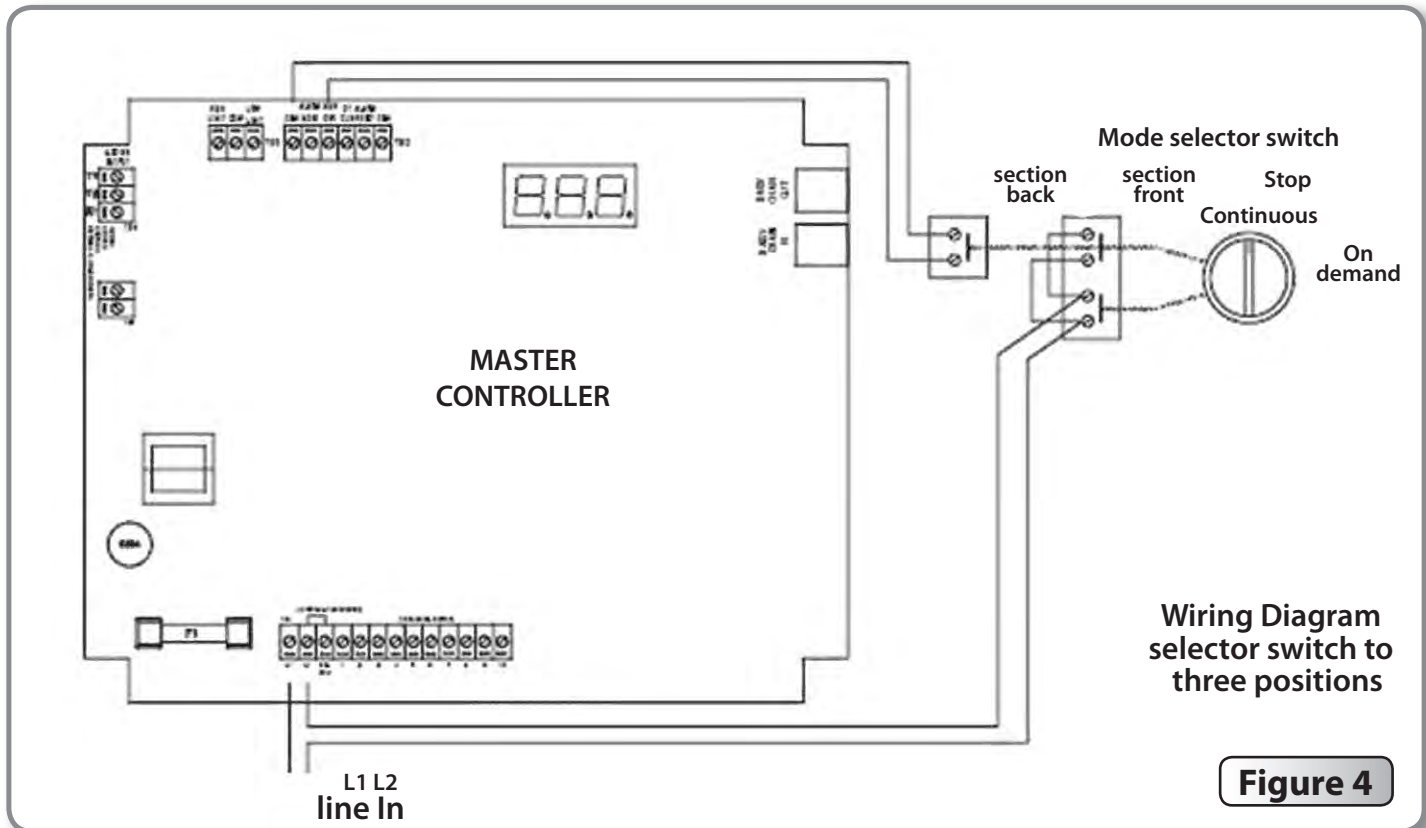

### 1.4.3 — Connecting the Alarm Relay

With the pressure module installed, a relay contact is provided for controlling an external alarm. This relay is a single-pole contact. It is activated when either of the high alarm limits is exceeded, or if the pressure falls below the low alarm threshold. The connection is made to the TB5 with a two-pin connector. See connections Figure 2

### 1.5 — Three Position Selection Switch Wiring

An optional mode selection switch is available with the weather Proof enclosure. With this switch the user may select either continuous cleaning, on-demand cleaning, or off. This switch is supplied factory wired as shown in Figure 4. The switch has a front and rear section. The front section, consisting of two independent contacts, controls the power to the board. These contacts must be wired in parallel as shown in the diagram. The rear section controls the manual override, which when closed will force the system into a continuous must be reconnected, follow the wiring diagram.



**Caution :** Do not interconnect the low voltage manual override leads with the power leads. This will destroy the control board as well as pose a serious shock hazard.



## **2.0 — PROGRAMMING THE DCT1000 MASTER CONTROLLER**

We've made it easy to navigate the DCT1000. Menu items can be accessed simply by pressing the "SELECT" button. The menu item that you are currently accessing is indicated by the illumination of an LED. To change menu items, all you have to do is push "UP" to increase a value or push "DOWN" to decrease a value. There are no keystrokes that you need to memorize, special combinations, or passwords that are required. The master controller is equipped with an on board display and programming information center. The controller will power-up with the process indicator illuminated. If a pressure module is installed, the display will indicate the measured pressure in inches of water (w.c.); otherwise it will normally be blank

### **2.1 — Last Output**

The Last Output setup selects the last channel to be activated. When first selected, the display will flash the last output available in the system. With single board installations, this will be the number of channels installed, typically 6, 10 or 22. This value becomes more important when multiple modules are installed. The last output value flashed will be the sum of all channels available in the system.

After the last available channel indication has completed, the currently programmed last channel value is displayed. This value may be changed using the "UP" and "DOWN" buttons. The minimum value is one while the maximum value is the maximum number of installed channels, including all expansion modules. The default value is the maximum number of channels. Pressing "SELECT" will change the setup mode to Time Off Setup.

### **2.2 — Time Off (Sec.)**

Time off defines the period of time between solenoid activations when no channels are enabled. This may be set between one second and 255 seconds. The factory default is 10 seconds. The display will show the current time off setting when the time off setup mode is entered. The value may be changed using the Up and Down buttons. Pressing both "UP" and "DOWN" simultaneously and holding for approximately four seconds will restore the default value of 10.

### **2.3 • Time On (millisec. )**

Time On Setup sets the solenoid on time. The display will indicate the currently programmed time on setting. This is measured in milliseconds. Using the "UP" and "DOWN" buttons, the value may be changed. The value may be set between 10 millisec. and 600 millisec. in 10 millisec. increments. Pressing the "UP" and "DOWN" buttons simultaneously for approximately four seconds will restore the factory default value of 100 millisec. . Pressing the "SELECT" button will advance the setup mode to the High Limit setup if the pressure module is installed. With no pressure module, it will step to Cycle Delay Setup.

### **2.4 • High Limit [Only available when DCP connected]**

The High Limit Setup, available only with a pressure module installed, sets the pressure at which the cleaning cycle will begin. This value may be between zero and the pressure module full scale pressure. Normally, the High Limit should be above the Low Limit. If, however, the High Limit pressure is set below the Low Limit, the cleaning cycle will begin when the High Limit is exceeded and stop when the pressure falls below the High Limit. The Low Limit in this case will have no effect. Pressing "SELECT" will change the system to the Low Limit Setup mode.

### **2.5 • Low Limit [Only available when DCP installed]**

The operation of the Low Limit, available only with a pressure module installed, is identical to the High Limit except this value sets the pressure where the cleaning cycle will end. The upper settable value is the calibration pressure of the pressure module and the lower limit is zero. Pressing "SELECT" will change the system to the High Alarm Setup mode.

## **2.0 — PROGRAMMING THE DCT1000 MASTER CONTROLLER (CONT'D)**

### **2.6 • High Alarm [Only available when DCP installed]**

The operation of the alarm system is identical to the high limit and low and high facility is only available if a pressure module is installed. The default value is 0 high alarm. The upper value adjustable pressure range is the maximum pressure module and the lower limit is zero. Pressing «SELECT» will change the system configuration to mode low alarm configuration.

### **2.7 • Low Alarm [Only available when DCP installed]**

The operation of the Low Alarm Setup is identical to the High and Low Limit Setup. The Low Alarm default is 0. The upper settable value is the full scale pressure of the pressure module and the lower limit is zero. Pressing "SELECT" will change the system to the Cycle Delay Setup mode.

### **2.8 • Cycle Delay (min)**

The cycle delay inserts a delay time between the end of the last channel and the beginning of the first channel. This may be set to between zero and 255 minutes. The factory default is zero. Setting the value to zero will disable the delay. Pressing "SELECT" will change the system to the Down Time Cycles Setup mode.

### **2.9 • Down Time Cycles (min)**

The Down Time Cycles setup will select a value between zero and 255 minutes. The factory default is one minute. Selecting zero will disable the operation. When the down time cycles is activated by shorting the down time cycles input to the common terminal, (see figure 2) the system will enter a forced cleaning mode for the programmed duration. NOTE: The cycle delay, if one is programmed, will not be inserted in the timing cycle. Pressing "SELECT" will change the system to the Auto Alarm Reset Setup mode, if a pressure module is installed, or to Process when no pressure module is available.

### **2.10 • Auto Alarm Reset (sec) [Only available when DCP installed]**

The Auto Alarm Reset Setup, available only when a pressure module is installed, allows the auto alarm reset time to be selected. This value may be set between zero and 255 seconds. The factory default value is five seconds. When the auto alarm reset is enabled by shorting the auto alarm reset terminal to a common terminal, (See Figure 1) the alarm will be reset after the pressure returns to the normal range and the timeout has expired. Pressing "SELECT" will change the system to Process mode. We have also included a number of features that will aid maintenance personnel in diagnosing problems or verifying that the system is operating.



## **3.0 — MAINTENANCE SUPPORT AND DIAGNOSTICS**

### **3.1 Restoring Factory Defaults**

The DCT1000 has been programmed with factory default values that meet most industry operating conditions. In the event that you want to restore all of the parameters to the original factory default values:

- (1) Return the master controller to the process mode.
- (2) Press and hold both “UP” and “DOWN” buttons.

The display will indicate a 10 second countdown, at the end of which all parameters will be restored to factory defaults. Releasing the switches prior to the end of the count will stop the process and no modification will be made. Likewise, in each of the parameter setup modes, pressing and holding the “UP” and “DOWN” buttons simultaneously will reset the individual default value, leaving other settings unchanged.

### **3.2 Power Indicator**

A power on LED indicator is provided at the center left edge of the board. This will be illuminated when the power supply is operating properly. If the power LED is not illuminated, the primary power may be off or there is a fault in the power circuit.

### **3.3 Active Channel Indicator**

Located just above the solenoid terminations, you will find that each channel is provided with an LED that is illuminated when the TRIAC switch is on. This allows a visual correlation between the channel being pulsed and the operation of the solenoid.

### **3.4 Comm Check Indicator**

The Comm Check Indicator can be found in the upper right hand corner of the slave and master controller board (just above the “out” terminal, a telephone style connector). This indicator is used for two purposes. First, on a master controller a brief flash once per second is produced to indicate that the system is operating. Second, this indicator is used to show when the communication check operation is performed on slave boards. The master controller will check each of the slave boards at a rate of about one inquiry per second, starting with the slave board connected directly to the master controller and ending with the last slave board in the chain. The master controller will flash its Comm Check LED for about 250 millise. each time it makes a communication check. The external module selected for test will also flash its Comm Check LED for about the same time each time it is interrogated. Observing this test sequence will indicate that the communication between boards is operational. When a slave board powers up, the Comm Check LED will be illuminated continuously. It will be extinguished when the master controller has initialized its communication channel. This indicator then shows that a master controller is operating and that each slave board is responding properly on the daisy chain.



## 3.0 — MAINTENANCE SUPPORT AND DIAGNOSTICS

### 3.5 Error Codes

Error codes will be displayed on the three-digit display when certain faults occur. Most of these indicators are associated with the daisy chain communication, but certain error codes pertain to single board operation also. These codes are :

DISPLAY	MEANING	ACTION REQUIRED
<b>Err 1</b>	This is a “watchdog” reset that is enabled when the master controller isn’t able to cycle through its operation.	Make sure all electrical connections are appropriately shielded so the master controller is not disrupted by noise.
<b>Err 2</b>	The pressure module has failed to respond to the request of the master controller.	The master controller will try to recover from the fault. If unsuccessful, replace the pressure module.
<b>Err 3</b>	Communication error in the daisy chain interface. This will only appear when the master controller is used in conjunction with a slave board.	Make sure the control cable used in the daisy chain interface is properly shielded from noise.
<b>Err 4</b>	The master controller has detected a change in module configuration or a fault in one of the modules.	Reinstall all modules in accordance with the instructions in the factory IOM.
<b>Err 5</b>	If the fault described in “Err 4” is not corrected, the master controller will reconfigure the modules that are responding properly and operate at a degraded condition.	Reinstall all modules. Contact factory if the problem persists.
<b>Err 6</b>	A message error affecting the software of the master controller or one of its modules.	Check the integrity of all connecting cables used to drive slave boards for additional solenoids. Also check the electrical grounding of the system installation.
<b>Err 7</b>	Indicates that one of the TRIAC drivers are not functioning.	Return to factory for evaluation and repair.
<b>Err 8</b>	Internal Error.	Contact the factory.
<b>Err 9</b>	Unassigned message code.	Contact the factory.

## 4.0 — GLOSSARY OF TERMS

- **Run Mode:** The term used when the timer board is firing the solenoids.
- **Pressure Module:** The pressure measurement subsystem that includes the software and hardware for on-demand cleaning, alarms and signal retransmission of the process variable (i.e., the differential pressure across the dust bags).
- **Master Controller:** The primary timer board that contains all of the major features, connections for external inputs and power to drive the DCT1000 Dust Collector Timer Controller system.
- **Power Guard:** A plastic shield that covers the output triacs and other line voltage circuitry.
- **Demand Cycle Mode:** A process in which the run mode is enabled through the on-board pressure module or an external switch such as the Dwyer Photohelic®.
- **Euro Connector:** A “caged” connection used to terminate solenoids, incoming power, or external switches on the DCT1000.
- **Continuous Cycle Mode:** A time based cycling mode dependent on solenoid time on/off settings and time set between complete cycles.
- **Manual Override:** Allows the user to override the DCT1000 remotely or from the master controller panel through use of a switch or a wire jumper.
- **Slave Board:** A channel expander that is used in conjunction with the master controller to accommodate additional solenoids on larger dust collection systems. It can be recognized easily as it does not have the on-board display panel or the power supply present. A master controller may also be used as a slave board.

## SERIES DCP100A/200A PRESSURE MODULES

### SPECIFICATIONS – INSTALLATION & OPERATING INSTRUCTIONS

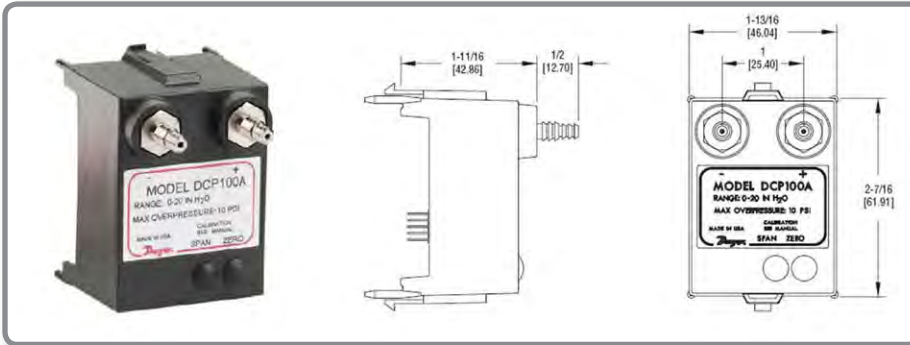

The DCP100A or DCP200A pressure modules are designed exclusively for use with the Dwyer DCT1000 Dust Collector Timer Controller boards for on-demand cleaning requirements. These series of modules are available in 10" w.c. [2.49 kPa] or 20" w.c. [4.98 kPa] ranges, which allow for differential process pressure measurement as indicated on the display of the master controller. An isolated 4-20 mA readout channel is

provided for remote pressure display. The 4-20 mA output may be wired either for use with an external power supply and indicator or using the isolated on-board 24 volt power supply to power the loop.

### SPECIFICATIONS

- Pressure Ranges: ..... 10" w.c. or 20" w.c.
- Temperature Limits: ..... -40 to 140°F (-40 to 60°C).
- Pressure Limit: ..... 10 psi (68.95 kPa).
- Pressure Limit (differential): ..... 10 psi (68.95 kPa).
- Accuracy: ..... ±1.5% F.S. @ 73°F(22.8°C).
- Output Signal: ..... 4-20 mA.
- Alarm Contacts: ..... 1.5 A inductive load, 3 A resistive load @ 30 V AC or 40 V DC.
- Process Connections: ..... Two barbed connections for use with 1/8" (3.18 mm) or 3/16" (4.76 mm) I.D. tubing.

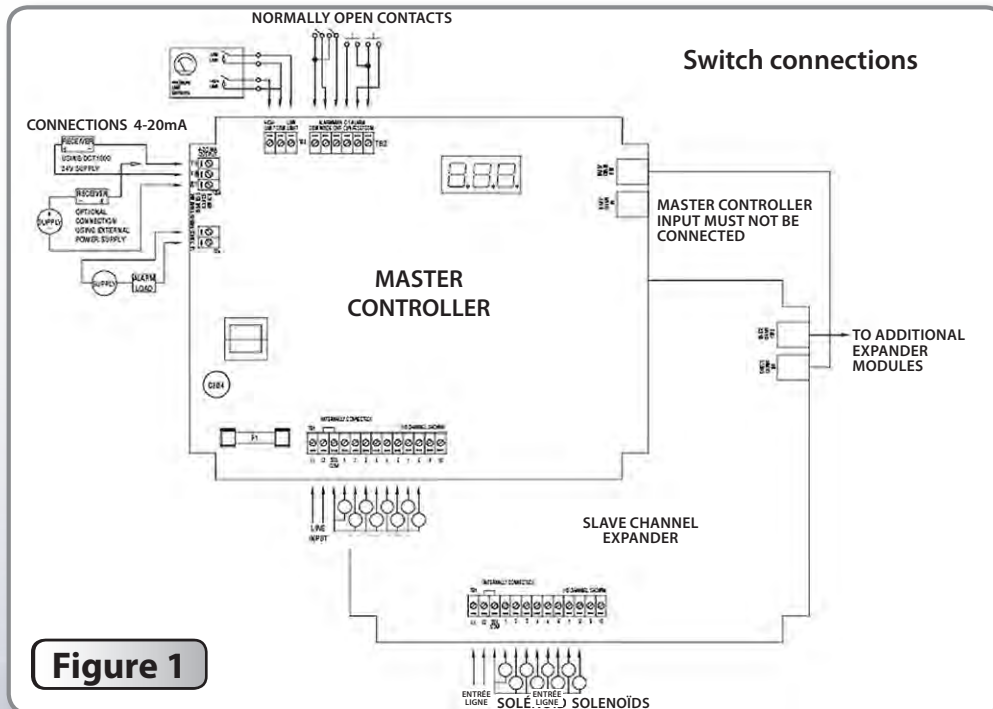

**Figure 1**



## SERIES DCP100A/200A PRESSURE MODULES (CONT'D)

### Specifications – Installation & Operating Instructions

#### 1.0 — INSTALLATION



**Caution :** Prior to installing the DCP100A/200A please review the operating specifications carefully. Some operating systems, especially in pneumatic conveying applications, may see static pressure or vacuum conditions that exceed the capability of the DCP100A/200A pressure module. For these conditions there are a number of alternate Dwyer pressure products that can be used to meet your application requirements, all of which can be terminated to the Dwyer DCT1000 Dust Collector Timer Controller. For more information on these and other Dwyer products, please call us at (219) 879-8000, or visit us on the web at [www.dwyer-inst.com](http://www.dwyer-inst.com) or [www.dust-controls.com](http://www.dust-controls.com)

#### 1.1 — Location

The system should be located in an enclosure that meets relevant safety standards and electrical codes. There are no other special orientation requirements as the pressure module is not orientation sensitive. Care should be observed when routing the air hoses to ensure that any potential condensation or moisture will not drain into the sensor. Where heavy condensation is present, a drip loop or an in-line filter should be installed to ensure long term operation.

#### 1.2 — Connections

When a pressure module is installed, the 4- 20 mA process signal and the alarm relay contacts are available. The circuit may be used with the internal 24 V power source or with an external source. In either case, the 4-20 mA circuit is isolated from ground and other signals.

The alarm relay contacts are isolated, normally open contacts. Pressure connections may be made to the stepped hose barbs with either 1/8" or 3/16" I.D. tubing. The following subparagraphs describe the external switch connections. Refer to Figure 1 (above) for switch connection illustration.

#### 1.3 — Pressure Module Installation

The pressure module is attached to the Master Controller using integral connectors on both units. The insertion ports for the pressure module are located in the upper left quadrant of the DCT1000 Master Controller. The pressure module can be removed by compressing the retaining clips on each end of the module, then gently pulling the module out of the master controller board. When inserting the module, the following procedure should be adhered to insure proper installation:

- Examine the bottom of the pressure module and note the orientation of the connectors.
- Align the module so that these connectors match the connector receptacles on the controller board.
- Orient the module with the four alignment pins over their respective mounting holes.
- Gently press the module into the connectors and snap the retaining clips on either end of the module into their slots.
- Always install and service this device with the power off and a lockout installed if required. "Hot" plugging the pressure module into an operating system may damage the system or cause the calibration parameters to be erased.



**Caution :** Do not force the module into the connectors. Forcing the insertion may damage the connectors. Properly aligned, the module should snap into place.

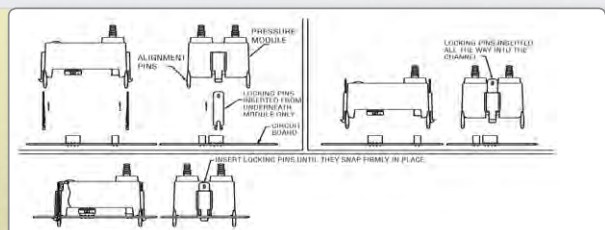

## SERIES DCP100A/200A PRESSURE MODULES

### **Specifications – Installation & Operating Instructions**

#### 2.0 - DEMAND MODE USING A DCP100A/200A PRESSURE

The DCT1000 system may be configured to be a self-contained on-demand control system with the installation of the DCP100A /200A pressure module. When this module is installed, the master controller detects it and automatically sets the system to an on demand mode, enabling features associated with the pressure sensor. The following subparagraphs describe the setup and operation of these pressure related features.

##### **2-1 — High Limit Setup**

The High Limit Setup sets the pressure at which the cleaning cycle will begin. This value may be between zero and the pressure module calibration pressure. Normally, the High Limit should be above the Low Limit. If, however, the High Limit pressure is set below the Low Limit, the cleaning cycle will begin when the High Limit is exceeded and stop when the pressure falls below the High Limit. The Low Limit in this case will have no effect. Pressing both Up and Down buttons simultaneously and holding for about four seconds will restore the factory setting for High Limit to 5.0" w.c. [1.24 kPa].

##### **2.2 — Low Limit Setup**

The operation of the Low Limit mode is identical to the High Limit mode except that the default Low Limit pressure is 3.0" w.c.[0.75 kPa]. The upper settable value is the calibration pressure of the pressure module and the lower limit is zero. Press the Select button until the Low Limit indicator is illuminated. Use the Up and Down controls to set the limit to the desired setting. Pressing both Up and Down buttons simultaneously and holding for about four seconds will restore the factory default.

##### **2.3 — High Alarm Setup**

The operation of the High Alarm Setup is identical to the High and Low Limit Setup. The High Alarm default is 0.0" w.c. The upper settable value is the calibration pressure of the pressure module and the lower limit is zero. Press the Select button until the High Alarm indicator is illuminated. Use the Up and Down controls to set the limit to the desired setting. Pressing both Up and Down buttons simultaneously and holding for about four seconds will restore the factory default.

##### **2.4 — Low Alarm Setup**

The operation of the Low Alarm Setup is identical to the High and Low Limit Setup. The Low Alarm default is 0.0" w.c. The upper settable value is the calibration pressure of the pressure module and the lower limit is zero. Press the Select button until the Low Alarm indicator is illuminated. Use the Up and Down controls to set the limit to the desired setting. Pressing both Up and Down buttons simultaneously and holding for about four seconds will restore the factor default.

##### **2.5 — Auto Alarm Reset Setup**

The Auto Alarm Reset Setup mode allows the auto alarm reset time to be selected. This value may be set between zero and 255 seconds. The factory default value is five seconds. When the auto alarm reset is enabled by shorting the auto alarm reset terminal to a common terminal, the alarm will be reset after the pressure returns to the normal range and the selected timeout period has expired.

#### 3.0 PRESSURE MODULE MAINTENANCE

The pressure module should require very little maintenance under normal operational conditions. However, periodic calibration may be desirable to assure accuracy of the readings. The module may be removed and returned to the factory for calibration.



## **ISTBLAST LIMITED WARRANTY**

**ISTblast** warrants all equipment led in this manual which is manufactured by **ISTblast** and bearing its name, to be free from defects in material and workmanship on the date of sale by an authorized **ISTblast** distributor to the original purchaser for use. Not with standing any special, extended or limited warranty published by **ISTblast** will, for a period of TWELVE (12) months from the date of sale, repair or replace any part of the equipment determined by **ISTblast** to be defective. This warranty applies only when the equipment is installed, operated and maintained in accordance with **ISTblast** 's written recommendations.

This warranty does not cover, and **ISTblast** shall not be liable for general wear and tear, or any malfunction, damage or wear caused by faulty installation, misapplication, abrasion, corrosion, inadequate or improper maintenance, negligence, accident, tampering, or substitution of non- **ISTblast** component parts. Nor shall **ISTblast** be liable for malfunction, damage or wear caused by the incompatibility with **ISTblast** equipment with structures, accessories, equipment or materials not supplied by **ISTblast** , or the improper design, manufacture, installation, operation or maintenance of structures, accessories, equipment or materials not supplied by **ISTblast** .

This warranty is conditioned upon the prepaid return of the equipment claimed to be defective to an authorized **ISTblast** distributor for verification of the claimed defect. If the claimed defect is verified, **ISTblast** will repair or replace free of charge any defective parts. The equipment will be returned to the original purchaser, transportation prepaid. If the inspection of the equipment does not disclose any defect in material or workmanship, repairs will be made at a reasonable charge, which charges may include the costs of parts, labor, and transportation.

**THIS WARRANTY IS EXCLUSIVE, AND IS IN LIEU OF ANY OTHER WARRANTIES, EXPRESSED OR IMPLIED, INCLUDING BUT NOT LIMITED TO WARRANTY OF MERCHANTABILITY OR WARRANTY OF FITNESS FOR A PARTICULAR PURPOSE.**

**ISTblast** 's sole obligation and the buyer's sole remedy for any breach of warranty shall be as set forth above. The buyer agrees that no other remedy (including, but not limited to, incidental or consequential damages for lost profits, lost sales, injury to person or property, or any other incidental or consequential loss) shall be available. Any action for breach of warranty must be brought forward within one (1) year of the date of sale.

**ISTblast MAKES NO WARRANTY, AND DISCLAIMS ALL IMPLIED WARRANTIES OF MERCHANTABILITY AND FITNESS FOR A PARTICULAR PURPOSE, IN CONNECTION WITH ACCESSORIES, EQUIPMENT, MATERIALS OR COMPONENTS SOLD BUT NOT MANUFACTURED BY ISTblast .** These items sold, but not manufactured by **ISTblast** (such as electric motors, switches, hose, etc.), are subject to the warranty, if any, of their manufacturer. **ISTblast** will provide the purchaser with reasonable assistance in making any claim for breach of these warranties.

### **LIMITATION OF LIABILITY**

In no event will **ISTblast** be liable for indirect, incidental, special or consequential damages resulting from **ISTblast** supplying equipment hereunder, or the furnishing, performance, or use of any products or other goods sold hereto, whether due to a breach of contract, breach of warranty, the negligence of **ISTblast** , or otherwise.

**Report all accidents or "near misses" which involve ISTblast products to:  
Technical Assistance**

**The following items are not covered under the ISTblast warranty policy:  
Parts or chassis replacement due to normal wears.**

**Defective material or workmanship is not considered normal wear**





**INFORMATION / TECHNICAL ASSISTANCE**

**ISTblast** is a registered trademark of:



For more information, pricing or technical support, contact your local IST distributor or call / fax to our Consumer Information numbers:

**TEL.: 1 877 629-8202 & 450 963-4400**

Or visit us at:  
**[istsurface.com](http://istsurface.com)**

## ABOUT THE COMPANY

### WHO WE ARE

IST is a leading manufacturer of equipment for the surface treatment industry and the solvent recycling industry. Our extensive line of equipment includes batch units and automated machines designed to achieve the highest manufacturing standards.

### MISSION

IST works tightly with their customers to transform industrial processes to improve their quality, productivity, and environmental footprint.

### OUR SERVICES

- Custom Design & Fabrication
- Installation & Startup
- Preventative Maintenance Program
- Private Labels
- Testing Lab
- 24/7 Technical Support 5656

### INDUSTRIES WE SERVE

- Aerospace & Aviation
- Aluminium Smelters
- Automotive
- Construction & Civil Engineering
- Flexography (labelling) & Lithography
- Foundry & Forge
- General Manufacturing
- Military
- Power & Energy
- Rail & Mass Transit
- Shipyards
- Wood finishing

