

DUST COLLECTOR
DCM 200 FOR MRS 200



- Warranty
- Safety
- Operation

- Service Parts
- Accessory Information
- Registration Form



INSTRUCTION MANUAL

2023-10-03

TABLE OF CONTENTS

	Page
INTRODUCTION - INSTALLATION	3
NOTICE TO PURCHASERS AND USERS OF OUR PRODUCTS AND THIS INFORMATIONAL MATERIAL	4
USE AND EQUIPMENT MAINTENANCE	5
GENERAL SAFETY RULES - PERSONAL SAFETY - UNIT USE AND	5
PERSONAL SAFETY	5
MUFFLER (OPTIONAL)	6
INSTALLATION	6
INSTALLATION (CONT'D)	7
INSTALLATION (END)	8
MAINTENANCE	8
MAINTENANCE (CONT'D)	9
PREVENTIVE MAINTENANCE SCHEDULE	10
DCM 200 DIAGRAM	11
DCM 200 - OPTION DUST COLLECTOR DRUM AND MUFFLER	12
DCM200 INTERIOR DIAGRAM	13
DCM200 INTERIOR DIAGRAM (CONT'D)	14
SPARE PARTS FOR DCM 200	15
ISTBLAST LIMITED WARRANTY	16
ISTBLAST WARRANTY REGISTRATION	17
WARRANTY INFORMATION / TECHNICAL ASSISTANCE	18
OUR LOCATION	19
OUR MISSION	20

INTRODUCTION - INSTALLATION

Welcome to the ISTblast® family of sandblasting products. This booklet contains helpful information and acquaints you with the operation and maintenance of your equipment. Please read carefully and follow our recommendations to assure trouble free operation. If you have any questions, please do not hesitate to contact your distributor or our technical service.

1. Carefully inspect the shipping carton for any signs of transport damage. The damage to the carton often indicates possibility of transport damage to the equipment inside.
2. Carefully remove your ISTblast dust collector from the shipping carton and skid.
3. Check your equipment immediately to ensure that it is free of transport damage. Report any transport damage to the carrier without delay for possible claim procedures. ISTblast is not responsible for damage to equipment after it leaves our warehouse.
4. Check the equipment received and compare it with the parts you have received. If any parts are missing, contact the supplier you purchased the equipment from.

Before operating the ISTblast dust collector, read this Instruction Manual completely. All ISTblast products are engineered and manufactured to the highest performance standards and have been subjected to detail testing before shipment from the factory.

NOTICE TO PURCHASERS AND USERS OF OUR PRODUCTS
AND THIS INFORMATIONAL MATERIAL

The products described in this material, and the information relating to those products, is intended for knowledgeable, experienced users of abrasive blasting equipment.

No representation is intended or made as to the suitability of the products described herein for any particular purpose of application. No representations are intended or made as to the efficiency, production rate, or the useful life of the products described herein.

Any estimate regarding production rates or production finishes are the responsibility of the user and must be derived solely from the user's experience and expertise, and must not be based on information in this material.

The products described in this material may be combined by the user in a variety of ways for purposes determined solely by the user. No representations are intended or made as to the suitability or engineering balance of the combination of products determined by the user in his selection, nor as to the compliance with regulations or standard practice of such combinations of components or products.

It is the responsibility of the knowledgeable, experienced users of the products mentioned in this material to familiarize themselves with the appropriate laws, regulations and safe practices that apply to these products, equipment that is connected to these products and materials that may be used with these products.

It is the responsibility of the user to insure that proper training of operators has been performed and a safe work environment is provided.

Our company is proud to provide a variety of products to the abrasive blasting industry, and we have confidence that the professionals in our industry will utilize their knowledge and expertise in the safe efficient use of these products.



« READ ALL INSTRUCTIONS » Failure to follow the SAFETY RULES identified by a BULLET (○) symbol listed BELOW and other safety precautions may result in serious personal injury.

« SAVE THESE INSTRUCTIONS »

GENERAL SAFETY RULES - PERSONAL SAFETY - UNIT USE AND CARE

- **KEEP WORK AREA CLEAN.**
- **KEEP CHILDREN AWAY.** Do not let visitors come in contact with the equipment. All visitors should be kept away from the work area.

PERSONAL SAFETY

- **GUARD AGAINST ELECTRIC SHOCK.** Non-skid footwear is recommended where damp or wet ground may be encountered. A ground fault circuit interrupter protected power line must be used for these conditions.
- **DRESS PROPERLY.** Do not wear loose clothing or jewelry. They can be caught in the moving parts. Wear protective hair covering to contain long hair.
- **USE SAFETY EQUIPMENT. WEAR SAFETY GOGGLES** or glasses with side shields.
- **WEAR A DUST PROOF MASK.**
- **STAY ALERT. USE YOUR COMMON SENSE.** Concentrate on what you are doing. Do not operate the unit when you are tired or under the influence of drugs or alcohol.
- **DO NOT OVERREACH.** Keep proper footing and balance at all times.

USE AND EQUIPMENT MAINTENANCE

- **BEFORE CONNECTING THE UNIT** to an electric current, make sure that the current is the same as that indicated on the identification plate of the collector. An electric current higher than indicated that could seriously injure the user and also damage the collector. If you have any doubts, do not connect the unit.
- **DO NOT FORCE THE EQUIPMENT.** It will perform better and more safely if it performs his duties the way it was designed.
- **USE OF ANY OTHER ACCESSORIES** not specified in this manual may be dangerous.
- **DISCONNECT THE UNIT** on its maintenance.
- **DO NOT ALTER OR IMPROPERLY USE THE UNIT.** These units are precision equipment. Alteration unspecified or modification can lead to a dangerous situation. Only a qualified technician should make all repairs (•), whether electrical or mechanical. Contact your nearest repair ISTblast service. Use only ISTblast original parts, the use of other parts carries a risk.

INSTALLATION

1. Make sure your dust collector is installed level, on a solid surface. Do not put it on a wood floor or rubber without first giving a grounding.
2. For your dust collector DCM model, an electrical connection is required. Consult an electrician.
3. For dust collectors having the dust barrel option, make sure the barrel is placed under the dust collector and securely connected to it.
4. For electric motors operating on 3 phases, ensure the rotation will be the same as that indicated by the arrow red and black on the motor casing.
5. For dust collectors equipped with **a muffler option** you must install it directly to the air outlet of the fan. Simply bolt it on the adapter. To ensure right air circulation, it is essential to keep 18 inches of clearance in front of the air outlet of the muffler.

MUFFLER (OPTIONAL)

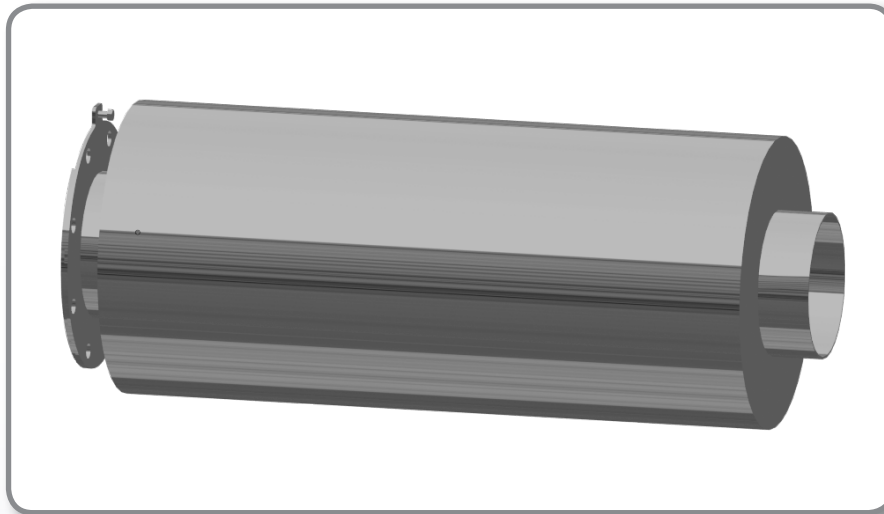

INSTALLATION (CONT'D)

- The dust collector must be installed leveled on the ground and close to the other elements (sandblasting vessel, recycler, etc. ...) Connect one end of the abrasive transport hose at the exit of the recycler (**1**) and the other end to the entrance at the bottom of the dust collector (**2**). Securing each end of the hose with the clamps included with the hose.



- Connect the power cord from the dust collector to a power source (see the electrical specification for voltage, amperage).

INSTALLATION (END)

8. Connect air supply as shown :



All electrical connections to the ISTblast equipment should be made by a qualified electrician and must adhere to the codes, standards, and procedures specified by the authority having jurisdiction.

ISTblast is not responsible for the connections made by the customer.

MAINTENANCE

1. Dust collector require a light coating of dust on their bags. During the first two weeks of operation and depending on your dust collector, it is very important to not shake the bags. For this reason, during the first hours of operation of your dust collector, the new bags will leave a little dust escaping from the air outlet.
2. A source of compressed air at **80 psi maximum** is necessary for the operation of the standard bag shaker of your device. You must connect your air source to the point: AIR INTAKE. For the standard model, this action is performed by a manual pneumatic shaker. Simply press the button next to the door about a dozen times (Fig. 2).

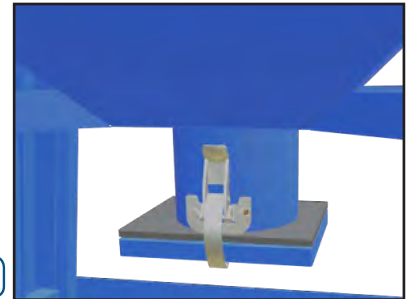

Fig. 2

MAINTENANCE (CONT'D)

3. If your dust collector is equipped with the **automatic shaker option (601429) 120 V, or (601427) 600 V**, the action will occur automatically at each motor shut down.

4. Remove dust from the dust collector on a regular basis. Before opening the door, make sure to have a container under the opening to collect the dust.



Picture 3

If you are equipped with the dust drum option simply open the lid with the ring's lever (**picture 4**) and empty the dust.



Picture 4

5. Never wash dust bags. If you have to clean them, use compressed air only, **blowing from the outside to the inside** of the bag (the opposite would clog the bag's pores and make it unusable). Replace torn bags as needed. For replacement parts, see parts lists at page 15.

IMPORTANT : Bag's shacking should never be performed while the electric motor is running. Always wait for complete stop of electric motor to avoid bag's tearing.

PREVENTIVE MAINTENANCE SCHEDULE

DAILY MAINTENANCE & OPERATION

Shake bag once a day at the end of shift when motor is off. (Not required with an automatic shaker)

MONTHLY MAINTENANCE

Waste drum : check level every week and empty if needed.

BI ANNUAL MAINTENANCE

Motor : Check bearing of the motor

IMPORTANT

It may be necessary to adjust the ventilation when using a different abrasive from the original one. Please contact us to obtain necessary information for a proper calibration of the system.

OPTION : AUTO-SHAKE COMMAND FROM ELECTRICAL PANEL

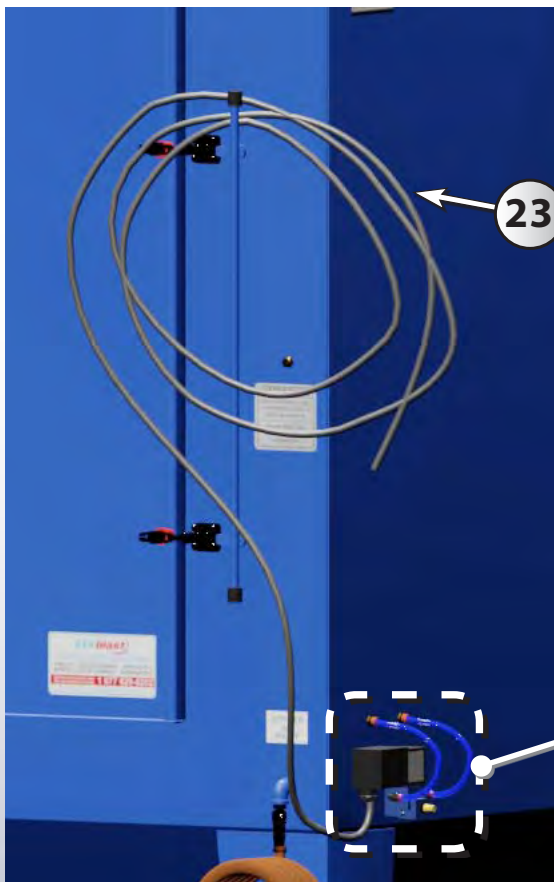

#	STOCK	DESCRIPTION <i>(All items are sold per foot or per unit)</i>
22	608568	SOLENOID VALVE
23	916607	CABLE 18GA 4 COND. BRAIDED SHIELD

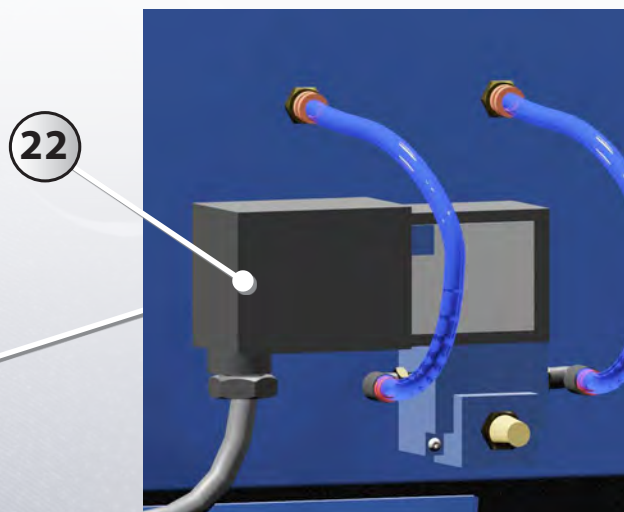

DCM 200 DIAGRAM



Front side

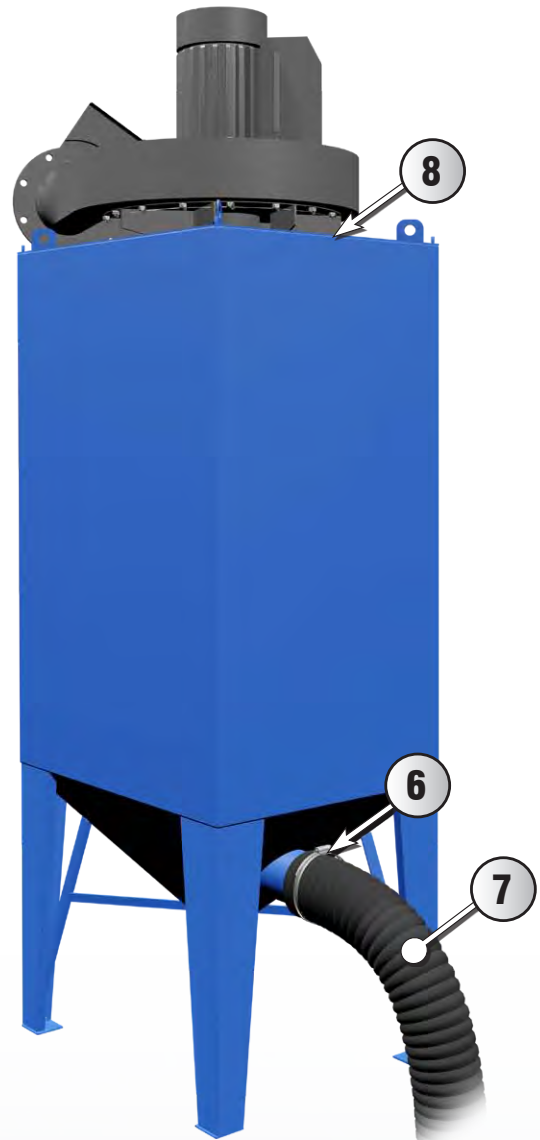

Back side

#	STOCK	DESCRIPTION (ALL ITEMS ARE SOLD PER FOOT OR PER UNIT)
1	916113	10 HP - 600V MOTOR (C/W TURBINE)
2	634240	NAME PLATE
3	607222	AIR INLET (1/4" MALE QUICK COUPLING)
4	600702	MULTIPUR HOSE KIT C/W 1/4" CONNECTOR
5	NPN	8" ADJUSTABLE AIR INLET
6	624128	CLAMPING RING
7	606173	8" Ø DUST CONVEYING HOSE, (SOLD PER FOOT)
8	618318	1/4" X 1/2" SELF-ADHESIVE RUBBER FOAM

RECOMMENDED SPARE PARTS

DESCRIPTION	PART NB
DB 6 bag (qty 30)	601316
Piston	608405

DCM 200 - OPTION DUST COLLECTOR DRUM AND MUFFLER

IF YOU HAVE THE DUST COLLECTOR DRUM OPTION:



- Place the support in a position to receive the collector. Pay attention to the position of the access door to bags.
- Place the dust collector in position on the support.
- Place the dust collecting drum under the dust collector and connect it by using the flexible hose.
- At the end of the installation, make sure to properly anchor the dust collector to the ground.

IF YOU HAVE THE DCM200 MUFFLER OPTION :

Muffler adjustment air inlet :

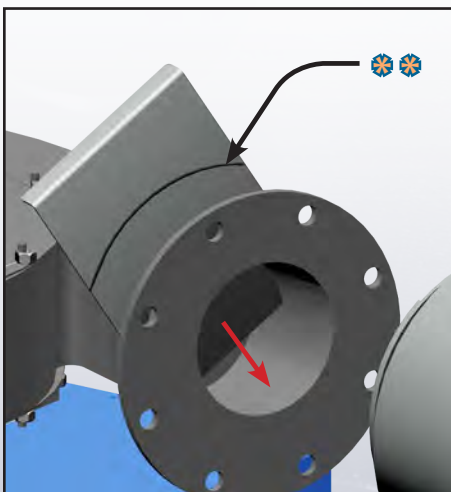

- It should be bolted directly to the output of the fan located on the dust collector. Make sure the exhaust gate valve is between the fan and the muffler. If required, adjust the gate valve to the **black mark** on the housing. ❄️❄️

❄️❄️ **Black mark** = *Factory calibration.*

ID	# STOCK	DESCRIPTION
1	916113	MOTOR 10 hp 600 V (C/W IMPELLER)
	916141	MOTOR 10 hp 460 V (C/W IMPELLER)
2	916086	HORIZONTAL MUFFLER 900 cfm

DCM200 INTERIOR DIAGRAM



#	STOCK	DESCRIPTION (ALL ITEMS ARE SOLD PER FOOT OR PER UNIT)
10	608406	CLEVIS ROD SHAFT
11	608405	3/4" DIA. X 3" STROKE CYLINDER
12	608407	BRACKET FOR CYLINDER
13	608408	FLOW ADJUST 10-32
14	608409	1/4" ADAPTOR
15	608508	PNEUMATIC SHAKER BUTTON
16	619005	2" WHEEL
17	601309	"S" HOOK

DCM200 INTERIOR DIAGRAM (CONT'D)

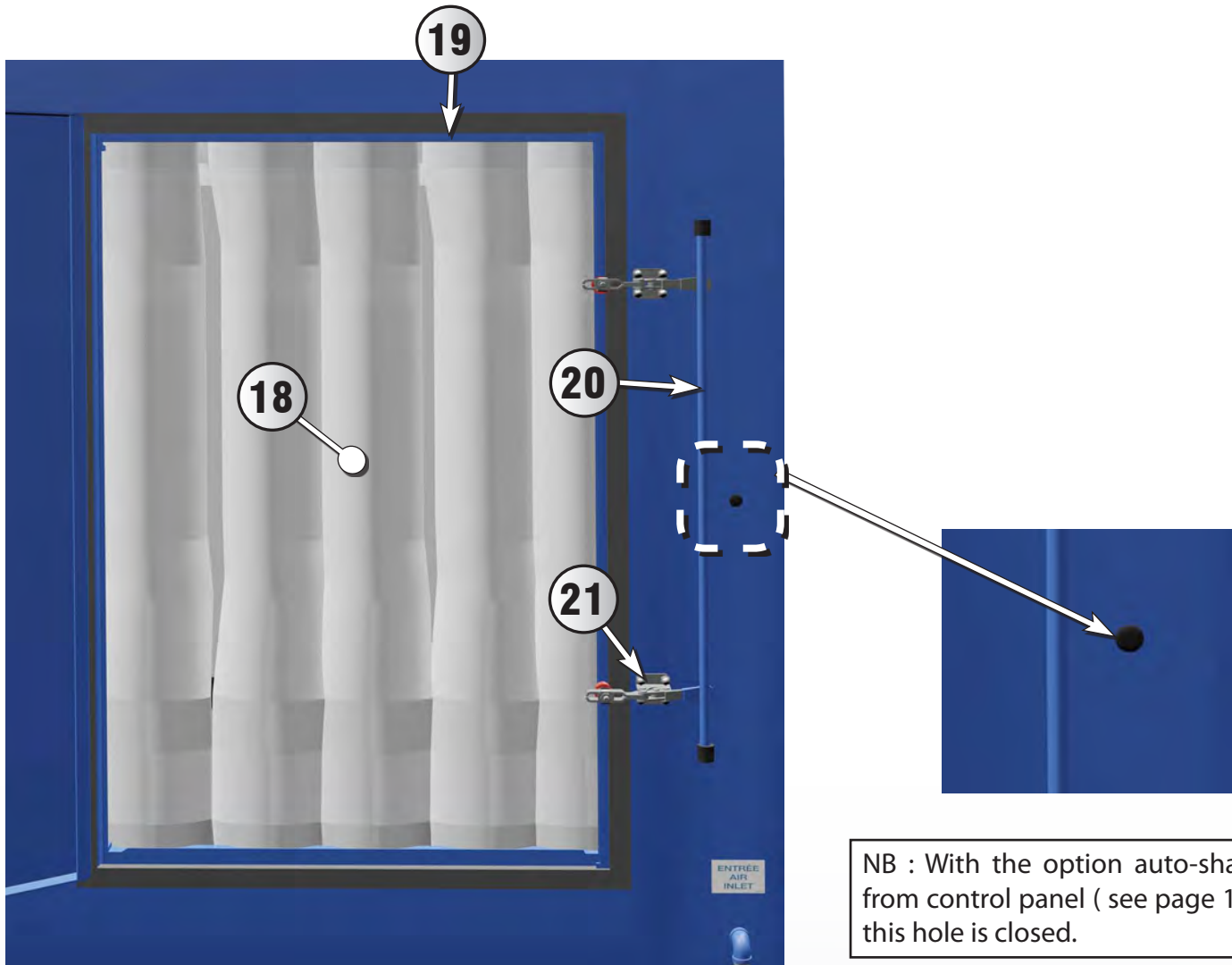

NB : With the option auto-shake from control panel (see page 14) this hole is closed.

#	STOCK	DESCRIPTION (ALL ITEMS ARE SOLD PER FOOT OR PER UNIT)
18	601316	DB 6 BAGS (QTY : 30)
19	618306	½" X ½" SELF-ADHESIVE RUBBER FOAM
20	610287	COMPLETE DOOR HANDLE
21	610223	DOOR LATCH

SPARE PARTS FOR DCM 200

STOCK	DESCRIPTION (ALL ITEMS ARE SOLD PER FOOT OR PER UNIT)
916113	10 hp - 600V Motor (c/w turbine)
634240	Name plate
608508	Pneumatic shaker button
607222	Air inlet (1/4" male quick coupling)
601371	Dust trap
618305	1/2 " x 1 " self-adhesive rubber foam (sold per foot)
610280	8" adjustable air inlet
618318	1/4" x 1/2" self-adhesive rubber foam
606173	8" Ø dust conveying hose, (sold per foot)
624128	Clamping ring
608406	Clevis rod shaft
608405	3/4" dia. x 3" stroke cylinder

STOCK	DESCRIPTION (ALL ITEMS ARE SOLD PER FOOT OR PER UNIT)
608407	Bracket for cylinder
608408	Flow adjust 10-32
608409	1/4" adaptor
608508	Pneumatic shaker button
619005	2" wheel
601309	"S" hook
601316	DB 6 bags (Qty : 30)
618306	1/2" x 1/2" self-adhesive rubber foam
610287	Complete door handle
610223	Door latch
606147	1/4" Ø multi-purpose hose

TROUBLESHOOTING

PROBLEME	POSSIBLE CAUSE	SOLUTION
La soufflerie ne démarre pas	<ul style="list-style-type: none"> • Source d'alimentation électrique déficiente 	<ul style="list-style-type: none"> • Vérifiez les fusibles dans le circuit
L'abrasif n'est pas aspiré	<ul style="list-style-type: none"> • Mauvais branchement électrique 	<ul style="list-style-type: none"> • Vérifiez la rotation du ventilateur
	<ul style="list-style-type: none"> • Sacs de dépoussiéreur bloqués 	<ul style="list-style-type: none"> • Assurez vous de bien secouer les sacs du dépoussiéreur. • Changer les sacs au besoin
	<ul style="list-style-type: none"> • Fuite d'air 	<ul style="list-style-type: none"> • Assurez vous qu'il n'y a pas de fuite dans les conduits ou boyaux de convoyage de l'abrasif. • Assurez vous de l'étanchéité du joint entre la sableuse et le système cyclonique.
L'abrasif se retrouve en grande quantité dans le dépoussiéreur	<ul style="list-style-type: none"> • Trop grande alimentation en air secondaire. 	<ul style="list-style-type: none"> • Recherchez une fuite d'air entre la sableuse et la trémie de stockage ou le recycleur (système cyclonique)

ISTBLAST LIMITED WARRANTY

ISTblast warrants all equipment led in this manual which is manufactured by ISTblast and bearing its name, to be free from defects in material and workmanship on the date of sale by an authorized ISTblast distributor to the original purchaser for use. Notwithstanding any special, extended or limited warranty published by ISTblast will, for a period of TWELVE (12) months from the date of sale, repair or replace any part of the equipment determined by ISTblast to be defective. This warranty applies only when the equipment is installed, operated and maintained in accordance with ISTblast's written recommendations.

This warranty does not cover, and ISTblast shall not be liable for general wear and tear, or any malfunction, damage or wear caused by faulty installation, misapplication, abrasion, corrosion, inadequate or improper maintenance, negligence, accident, tampering, or substitution of non-ISTblast component parts. Nor shall ISTblast be liable for malfunction, damage or wear caused by the incompatibility with ISTblast equipment with structures, accessories, equipment or materials not supplied by ISTblast, or the improper design, manufacture, installation, operation or maintenance of structures, accessories, equipment or materials not supplied by ISTblast.

This warranty is conditioned upon the prepaid return of the equipment claimed to be defective to an authorized ISTblast distributor for verification of the claimed defect. If the claimed defect is verified, ISTblast will repair or replace free of charge any defective parts. The equipment will be returned to the original purchaser, transportation prepaid. If the inspection of the equipment does not disclose any defect in material or workmanship, repairs will be made at a reasonable charge, which charges may include the costs of parts, labor, and transportation.

THIS WARRANTY IS EXCLUSIVE, AND IS IN LIEU OF ANY OTHER WARRANTIES, EXPRESSED OR IMPLIED, INCLUDING BUT NOT LIMITED TO WARRANTY OF MERCHANTABILITY OR WARRANTY OF FITNESS FOR A PARTICULAR PURPOSE.

ISTblast's sole obligation and the buyer's sole remedy for any breach of warranty shall be as set forth above. The buyer agrees that no other remedy (including, but not limited to, incidental or consequential damages for lost profits, lost sales, injury to person or property, or any other incidental or consequential loss) shall be available. Any action for breach of warranty must be brought forward within one (1) year of the date of sale.

ISTblast MAKES NO WARRANTY, AND DISCLAIMS ALL IMPLIED WARRANTIES OF MERCHANTABILITY AND FITNESS FOR A PARTICULAR PURPOSE, IN CONNECTION WITH ACCESSORIES, EQUIPMENT, MATERIALS OR COMPONENTS SOLD BUT NOT MANUFACTURED BY ISTblast. These items sold, but not manufactured by ISTblast (such as electric motors, switches, hose, etc.), are subject to the warranty, if any, of their manufacturer. ISTblast will provide the purchaser with reasonable assistance in making any claim for breach of these warranties.

LIMITATION OF LIABILITY

In no event will ISTblast be liable for indirect, incidental, special or consequential damages resulting from ISTblast supplying equipment hereunder, or the furnishing, performance, or use of any products or other goods sold hereto, whether due to a breach of contract, breach of warranty, the negligence of ISTblast, or otherwise.

Report all accidents or "near misses" which involve ISTblast products to:
- Technical Assistance

The following items are not covered under the ISTblast warranty policy:
- Parts or chassis replacement due to normal wears.

Report all accidents or negligence involving ISTblast products to our Service Department :

1 877 629-8202

INFORMATION / TECHNICAL ASSISTANCE

ISTblast is a registered trademark of:



For more information, pricing or technical support, contact your local IST distributor or call / fax to our Consumer Information numbers:

TEL.: 1 877 629-8202 & 450 963-4400

Or visit us at:
www.istsurface.com

OUR MAP LOCATION

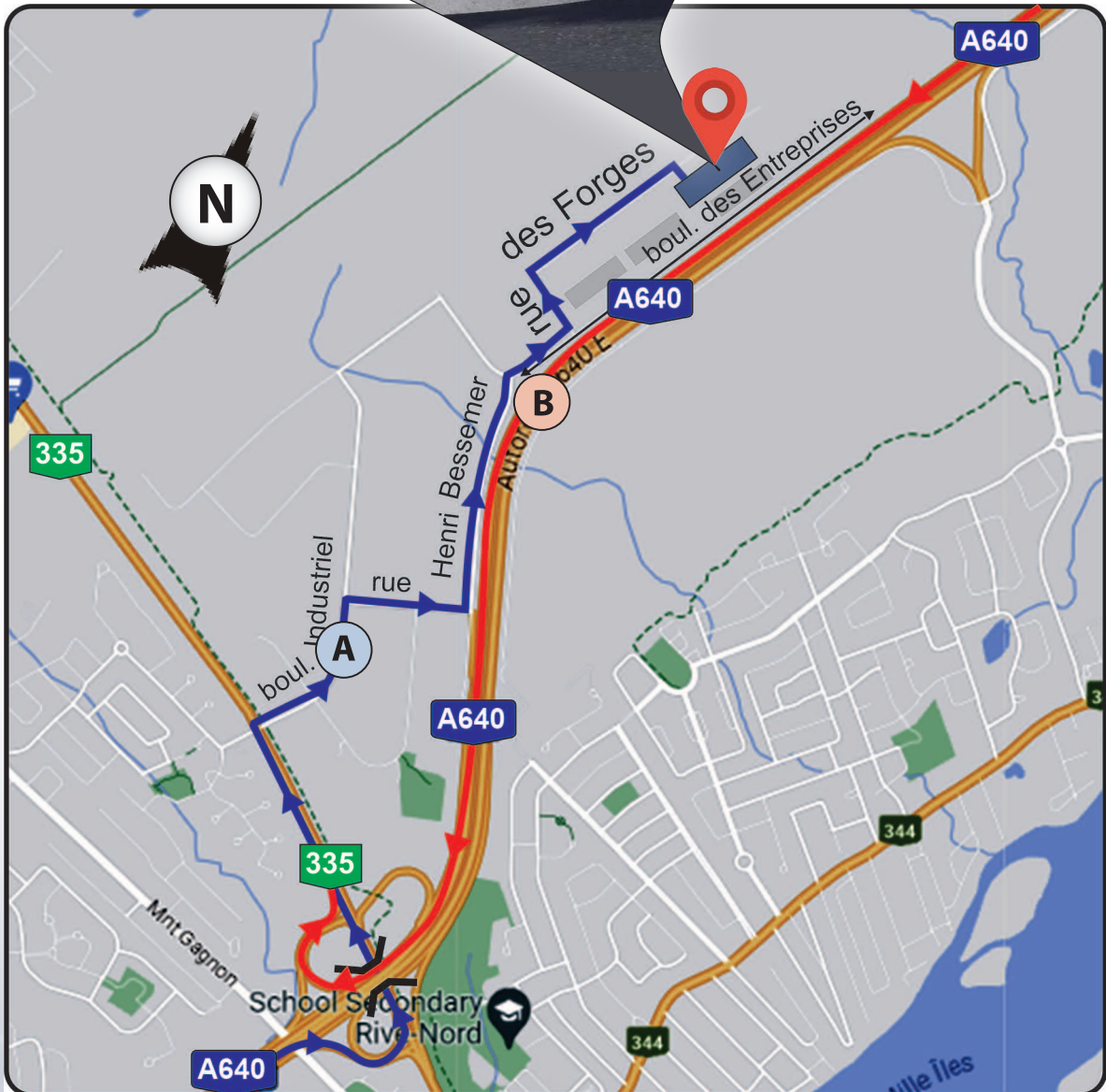

ABOUT THE COMPANY

WHO WE ARE

IST is a leading manufacturer of equipment for the surface treatment industry and the solvent recycling industry. Our extensive line of equipment includes batch units and automated machines designed to achieve the highest manufacturing standards.

MISSION

IST works tightly with their customers to transform industrial processes to improve their quality, productivity, and environmental footprint.

OUR SERVICES

- Custom Design & Fabrication
- Installation & Startup
- Preventative Maintenance Program
- Private Labels
- Testing Lab
- 24/7 Technical Support 5656

INDUSTRIES WE SERVE

- Aerospace & Aviation
- Aluminium Smelters
- Automotive
- Construction & Civil Engineering
- Flexography (labelling) & Lithography
- Foundry & Forge
- General Manufacturing
- Military
- Power & Energy
- Rail & Mass Transit
- Shipyards
- Wood finishing

