

## Y-TRACK SPINNER HANGER WITH INDEXING CAPABILITY

### TYPE SH 4860



ISTblast airless spinner hanger blast systems come in a variety of sizes. Rugged, long lasting, industrial equipment that provides versatility in blasting a wide range of part sizes and shapes.

The Spinner Hanger delivers high efficiency with center-fed blast wheels. A cast control cage in the wheel allows for management of the abrasive pattern achieving the highest percentage of shot impact on the work.

ISTblast equipment is designed for ease of maintenance and durability. Viking blast wheels proven reliability and longevity blend well with the heavy-duty construction of the Spinner Hanger and I-Beam style "Y" track conveyance.

#### MARKETS

- General manufacturing
- Industrial Equipment
- Metal forming
- Aerospace and aviation
- Rail and Transit
- Marine
- Automotive
- Power & Energy

#### FEATURES

- ✓ Cast lined blast chambers
- ✓ Manganese wheel housing and cast liners
- ✓ Heavy duty abrasive recycling system with
- ✓ air wash separator
- ✓ Light curtains standard to provide the highest level of operator safety
- ✓ Heavy duty, I-beam type "Y" track conveyance
- ✓ Rugged construction with 25% more weight than comparable equipment
- ✓ Multiple indexing
- ✓ Low and easy maintenance
- ✓ Heavy duty auger system
- ✓ Machine warranty
- ✓ Pre-wired and tested
- ✓ Rotary scalping drum
- ✓ PLC Control Panel comes as standard equipment

No other indexing spinner hanger blast system on the market today offers the many practical benefits like an ISTblast trough blaster as standard equipment. Just look at the features. The standard components in a ISTblast system have been carefully designed for safety, ease of operation, reduced maintenance and increased productivity.

It is in the customization of our basic designs to your parts specific needs that truly sets ISTblast apart from the competition. With an accomplished and proven design staff, ISTblast can build equipment from the ground up or simply modify existing models to tailor fit your cleaning application. At ISTblast we do not simply match your part to the closest machine size that will work. We match our blast equipment to your part, to provide the most efficient and economical cleaning solution possible.

**FLOOR PLAN**

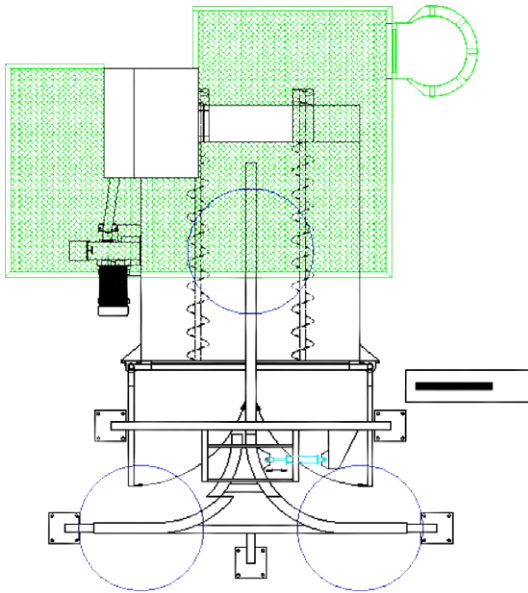

SH 4860Y Top view

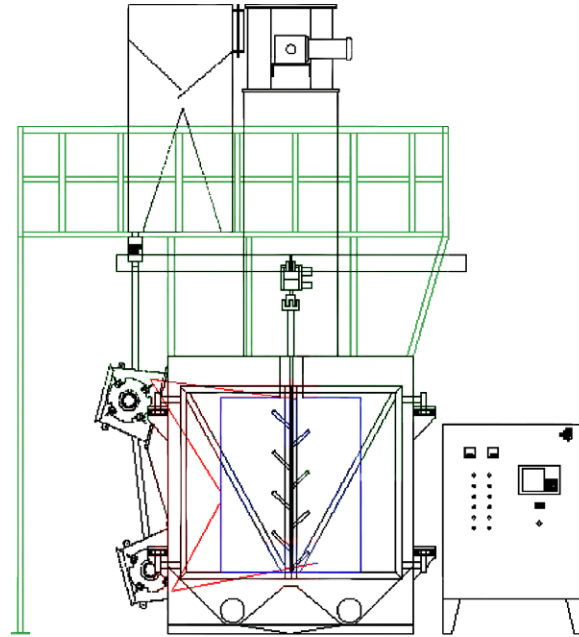

SH 4860Y Front view

**SPECIFICATIONS**

Description	
Work Envelope	48" Diam. x 60" H
Overall Dimensions	16'-7" L x 14'-9" W x 18'-6" H
Electrical	460 V, 3-Ph, 60 Hz
Abrasive Required	4 900 lb
Double Lip Type Airwash Separator	48"
Blast Wheels	
• Number of wheels	2
• Horsepower	30 hp
• Diameter	15" $\emptyset$
• rpm	3 600
Floor Space Required	18'-3" L x 16'-10" W

*Additional options available*