



BAG HOUSE DUST COLLECTOR

MODEL DC 50

The advantage of the DC50 dust collector is to circumvent the limitation imposed by the NFPA regulation; being an open type, the modular series is not restricted by the fact that systems above 400 cfm that need to be equipped on all anti-explosion devices..

The DC50 is an ideal solution for those looking for an affordable option to their dust collection needs.

The DC50 has can be used with existing sandblasting cabinets or can be purchased in combination with an ISTblast sandblasting cabinet. A great feature of the DC50 is that it does not use any compressed air thereby limiting the impact to your sandblasting operation.

The DC50 is a modular, manual shaker type, dust collector requiring minimal supervision and maintenance.

MARKETS

- General manufacturing
- Aerospace and aviation
- Marine
- Automotive
- Petroleum
- Power & energy
- Pharmaceutical

FEATURES

- ✓ Dust collector features an energy-saving air-filtration system capturing 99,5 % of all particles three (3) microns or larger.
- ✓ Low cost
- ✓ Small footprint
- ✓ Ease of access to the filter bags
- ✓ Replacement bags are readily available anywhere on the market
- ✓ Can be operated with either pressure or suction sandblasting cabinets.
- ✓ QPS approved in Canada and the U.S.



No other dust collector on the market today offers the many practical benefits included on a ISTblast dust collector as standard equipment. The standard components in a ISTblast system have been carefully designed for safety, ease of operation, reduced maintenance and increased productivity.

HOW IT WORKS

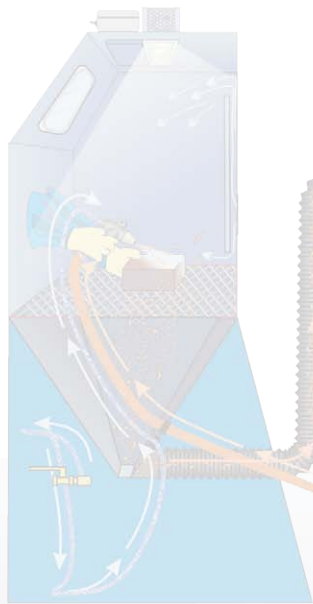

With standard blast cabinet

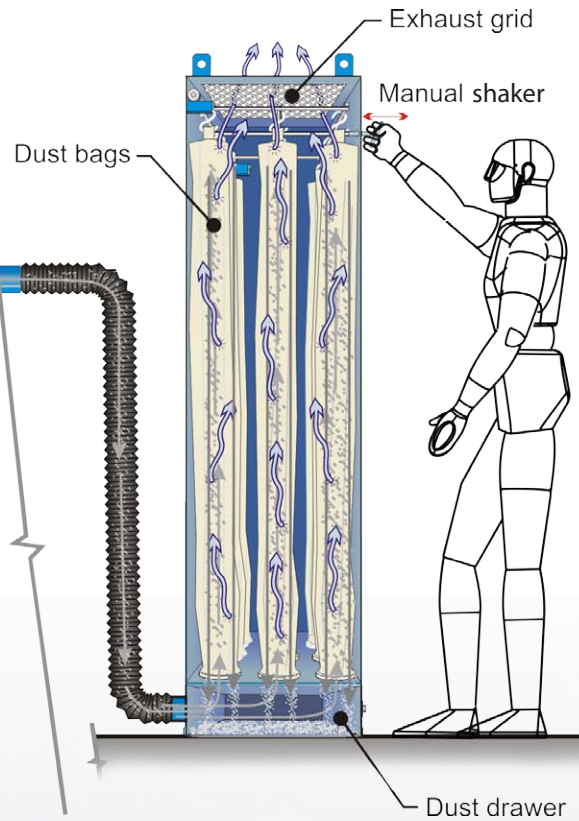

FLOOR

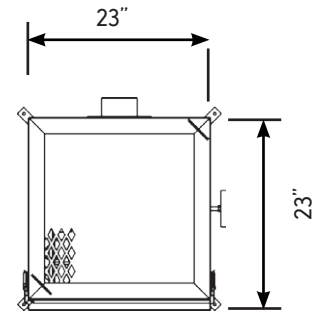

Plan view

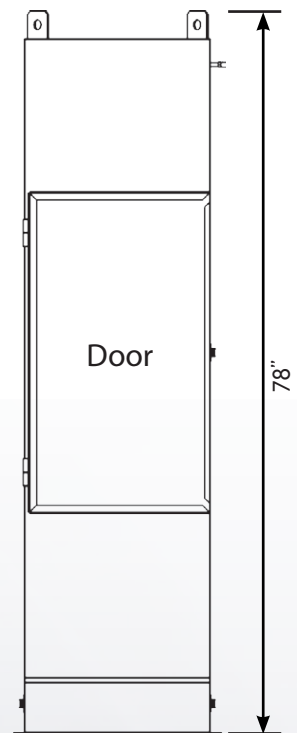

Elevation view

SPECIFICATIONS	DC50
Model number	625016
Filter Area (square feet)	50
Weight (lb)	250
Door opening (W x H)	20" x 35"