



## BAG-HOUSE DUST COLLECTORS

### SERIES DCM100 TO 330

The models DCM100 to 330 dust collectors are designed for heavy-duty use and are the most efficient for preventing dust from escaping into the work environment and contaminating surroundings machines and work environment.

It is ideal for those who can afford high-efficiency, low maintenance shaker dust collector with head motor.

These dust collectors DCM100 to 330 are the appropriate solution for dust filtration and collection of various applications with the use of very little compressed air.

the DCM100 TO 330 are automated, modular, automatic shaker type, dust collectors requiring minimal supervision and maintenance.

### MARKETS

- General manufacturing
- Aerospace and aviation
- Marine
- Automotive
- Petroleum
- Power & energy
- Pharmaceutical

### FEATURES

- ✓ Dust collector features an energy-saving air-filtration system captures 99,5 % of all particles three (3) microns or larger
- ✓ Bag-House dust collectors offer improved efficiency and durability (available in 600, 900 1,200 and 1,800 CFM models)
- ✓ Automatic shaker available as an option
- ✓ Efficient head motor exhausting system on the clean side of filter media
- ✓ Barrel dust outlet with trap door
- ✓ Ease of access to the filter bags
- ✓ Replacement bags readily available
- ✓ Can be operated with either pressure or suction sandblasting cabinets systems
- ✓ QPS approved in Canada and the U.S.



No other dust collector on the market today offers the many practical benefits included on a ISTblast dust collector as standard equipment. Just look at the features. The standard components in a ISTblast system have been carefully designed for safety, ease of operation, reduced maintenance and increased productivity.

## HOW IT WORKS

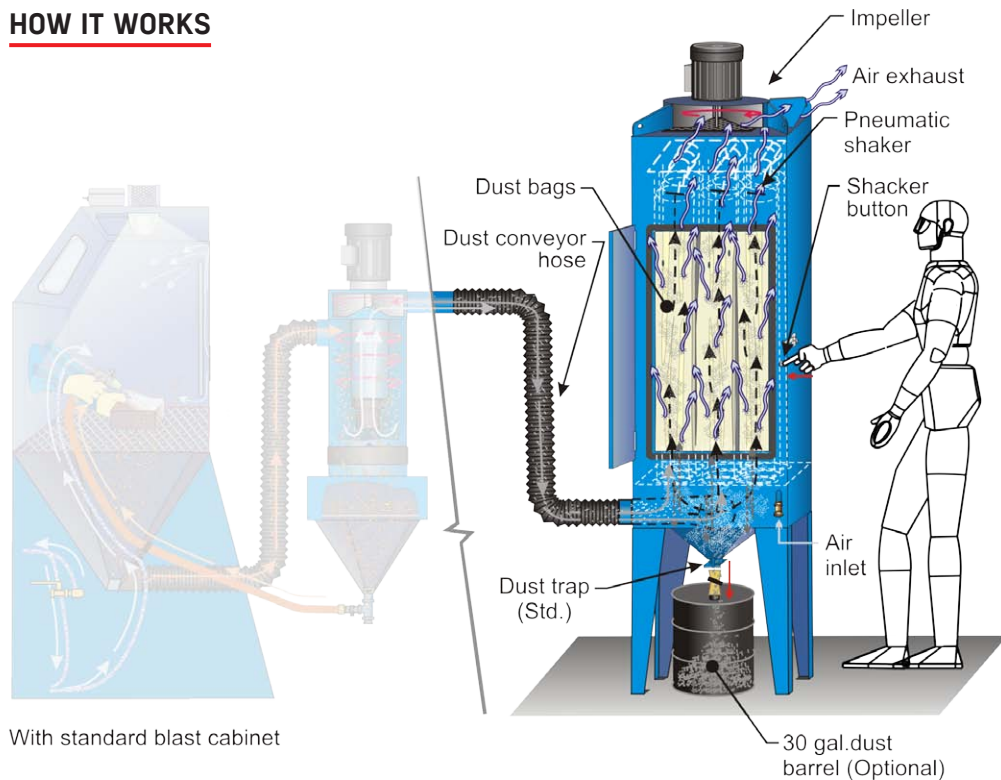

With standard blast cabinet

## FLOOR LAYOUT

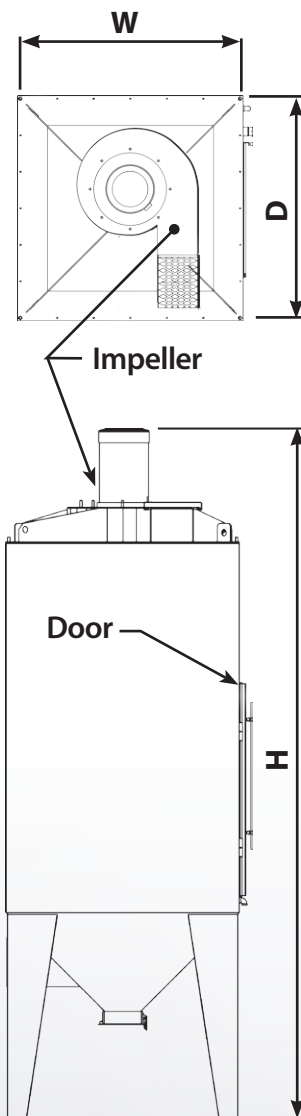

## SOME OPTIONS



Vertical muffer



Horizontal muffer

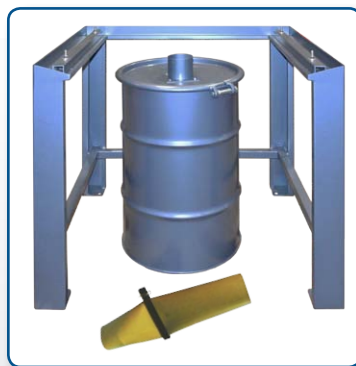

Extension feet and 30 gal barrel

## SPECIFICATIONS

Description	DCM100	DCM160	DCM230	DCM330
Model number	625025	625031	625037	625043
Filter Area (square feet)	100	160	230	330
Fan motor (hp/CFM)	1/600	2/900	3/1200	5/1800
Weight (lbs)	400	450	525	700
Overall dim's (DxW)	28" x 28"	32" x 32"	38" x 38"	38" x 38"
Overall height (H)	103"	105"	112"	137"
Door opening (WxH)	23" x 35"	23" x 35"	23" x 35"	23" x 35"