



CARTIDGE-TYPE DUST COLLECTORS

MODELS DCM600 TO 1800

The DCM600 to DCM1800 models are the most efficient and effective motorized dust collection systems in the work environment today. The automated fans can draw in air from the reclaimers from 600 to 1800 cfm.

Dust and fine particles that pass through the recycler are filtered and only clean air is exhausted from the system. The cartridges are cleaned by a pulse of compressed air blowing inside of them. The reverse pulse momentarily halts the flow of air passing through the cartridges in order to remove dust on the outer surface. The dust falls to the bottom to the barrel.

The pulses intervals are controlled by a sequential controller which collects and compares static pressure data on both dirty and clean side of filters simultaneously.

MARKETS

- General manufacturing
- Aerospace and aviation
- Marine
- Automotive
- Petroleum
- Power & energy
- Pharmaceutical

FEATURES

- ✓ Dust collector features an energy-saving air-filtration system capturing 99,9 % of all particles one (1) microns or larger
- ✓ Cartridge-type dust collectors offer improved efficiency and durability (available in 600, 900, 1,200, and 1,800 cfm models)
- ✓ Efficient motor exhausting system on the clean side of filter media
- ✓ The reverse-pulse shaker-system is automatically controlled by a timer
- ✓ Ease of access to the filter cartridges
- ✓ Can be operated with either pressure or suction sandblasting systems.
- ✓ QPS approved in Canada and the U.S.

No other dust collector on the market today offers the many practical benefits included on a ISTblast dust collector as standard equipment. Just look at the features. The standard components in a ISTblast system have been carefully designed for safety, ease of operation, reduced maintenance and increased productivity.

HOW IT WORKS

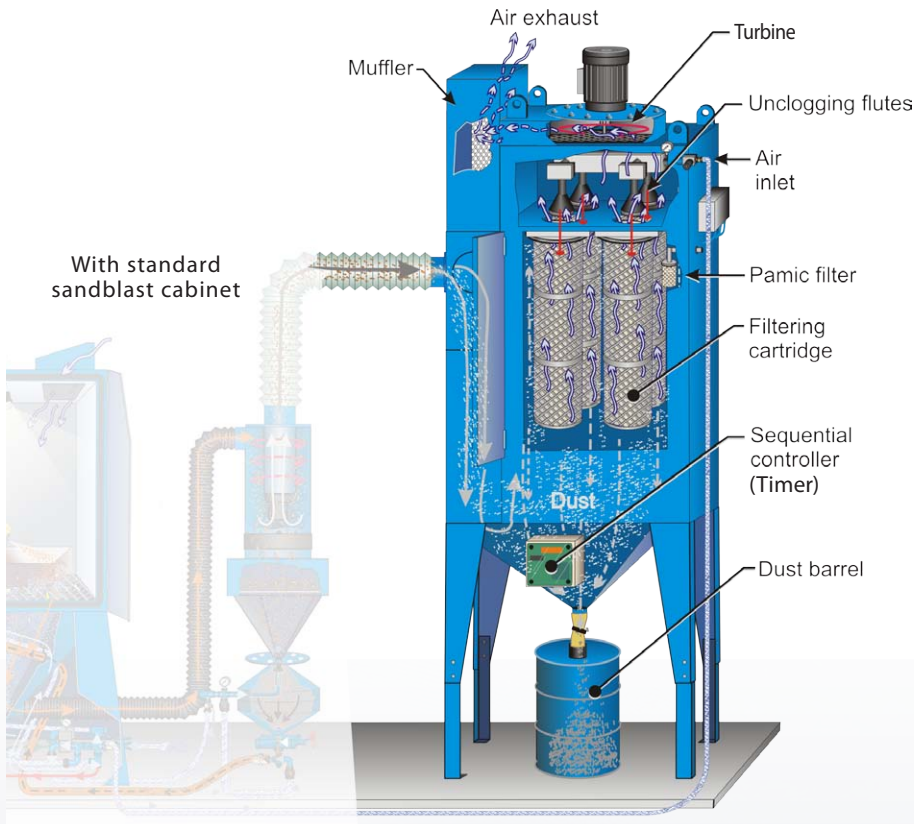

FLOOR PLAN

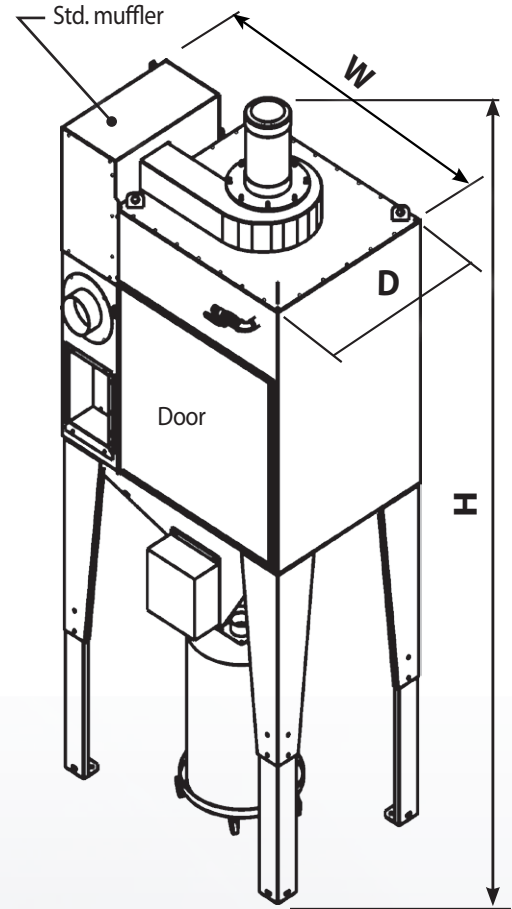

SPECIFICATIONS	DCM 600	DCM 900	DCM 1 200	DCM 1 800
Model number	625125	925016	625130	925010
Filter Area (square feet)	562	562	1,124	1,124
Fan motor capacity (hp/cfm)	1/600	2/900	3/1,200	5/1,800
Weight (lb)	900	915	1,100	1,150
Overall dim's (DxW)	42" x 41"	42" x 41"	55" x 37"	37" x 59"
Overall height (H)	122"	122"	137"	140"
Door opening (WxH)	23" x 37"	23" x 37"	42" x 40"	40" x 38"