



DUST COLLECTORS

MODELS DCM 600 TO 1 800

The DCM 600 to DCM 1 800 models are the most efficient and effective motorized dust collection systems in the work environment today. The automated fans can draw in air from the reclaimers from 600 to 1 800 cfm.

Dust and fine particles that pass through the recycler and are filtered, and only clean air is exhausted by the system. The cartridges are cleaned by a pulse of compressed air blowing inside of them. The reverse pulse momentarily halts the flow of air passing through the cartridges in order to remove dust on the outer surface. The dust falls to the bottom to the barrel.

The pulses intervals are controlled by a timer.

MARKETS

- General manufacturing
- Aerospace and aviation
- Marine
- Automotive
- Petroleum
- Power & energy
- Pharmaceutical

FEATURES

- ✓ Dust collector features an energy-saving air-filtration system capturing 99% of all particles one (1) microns or larger.
- ✓ Cartridges type dust collectors standard, offering improved efficiency and durability
- ✓ Efficient motor exhausting system
- ✓ The reverse-pulse shaker-system is automatically controlled by a timer.
- ✓ Ease of access to the filter cartridges
- ✓ Replacement cartridges readily available anywhere on the market
- ✓ Can be operated with either pressure or suction sandblasting cabinets.
- ✓ CSA approved and made in Canada.



No other dust collector on the market today offers the many practical benefits included on a ISTblast dust collector as standard equipment. Just look at the features. The standard components in a ISTblast system have been carefully designed for safety, ease of operation, reduced maintenance and increased productivity.

HOW IT WORKS

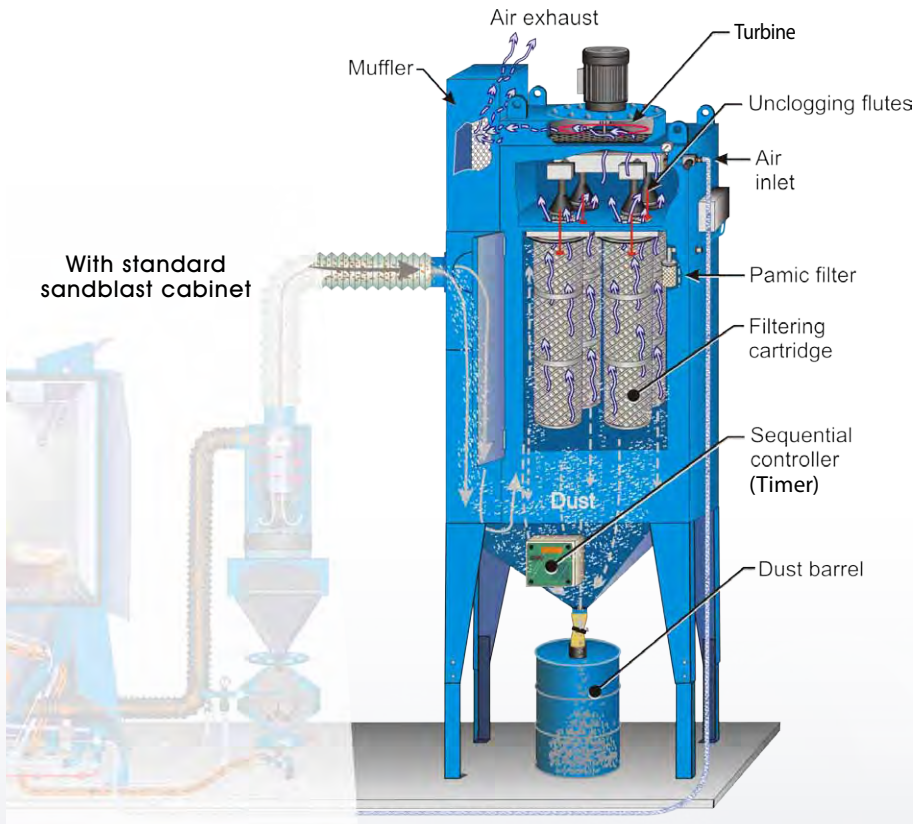

FLOOR PLAN

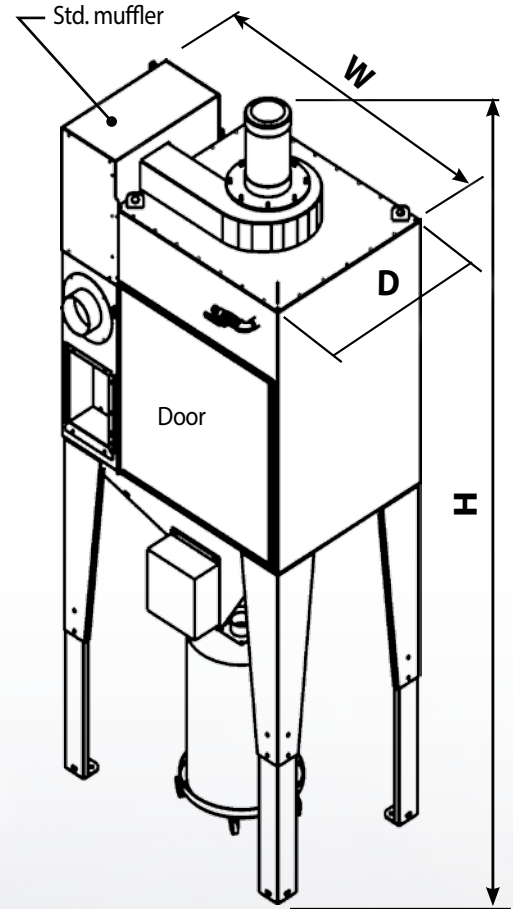

SPECIFICATIONS	DCM 600	DCM 900	DCM 1 200	DCM 1 800
Model number	625125	925016	625130	925010
Filter Area (square feet)	562	562	1 124	1 124
Fan motor capacity (cfm)	600	900	1 200	1 800
Weight (lb)	900	915	1 100	1 150
Overall dim's (D x W)	42" x 41"	42" x 41"	55" x 37"	37" x 59"
Overall height (H)	122"	122"	137"	140"
Door opening (W x H)	23" x 37"	23" x 37"	42" x 40"	40" x 38"