



SANDBLASTING BOOTH MECHANICAL RECOVERY SYSTEM WITH SCREW CONVEYOR AND BUCKET ELEVATOR



TABLE OF CONTENTS

	Page
INTRODUCTION	2 to 4
 SYSTEM OVERVIEW	 5
ABRASIVE MEDIA RECOVERY SYSTEM	6 to
12REMOTE CONTROL BOX.....	13
PRESSURE VESSEL.....	14, 15
 HMI	 16
HMI CONTROL PANEL MENUS.....	17 to 20
 MAINTENANCE	 21
SANBLAST BOOTH	22 to 25
BUCKET ELEVATOR.....	26
TROUBLESHOOTING.....	27
 SAFETY EQUIPMENT	 28
AIR BREATHING - PROTECTIVE EQUIPMENT FOR THE OPERATOR	29 to 33
BLAST SUITS	34
 ISTBLAST LIMITED WARRANTY	 35
 ABOUT THE COMPANY	 36

INTRODUCTION

Welcome to the ISTblast family of sandblasting products. This booklet contains helpful information and acquaints you with the operation and maintenance of your equipment. Please read carefully and follow our recommendations to assure trouble free operation. If you have any questions, please do not hesitate to contact your distributor or our technical service.

The products described in this manual, and the information relating to those products, is intended for knowledgeable, experienced users of abrasive blasting equipment.

No representation is intended or made as to the suitability of the products described herein for any particular purpose or application. No representations are intended or made as to the efficiency, production rate, or the useful life of the products described herein. Any estimate regarding production rates or production finishes are the responsibility of the user and must be derived solely from the user's experience and expertise, and must not be based on information in this manual.

The products described in this manual may be combined by the user in a variety of ways for purposes determined solely by the user. No representations are intended or made as to the suitability or engineering balance of the combination of products determined by the user in his selection, nor as to the compliance with regulations or standard practice of such combinations of components or products.

It is the responsibility of the knowledgeable, experienced users of the products mentioned in this manual to familiarize themselves with the appropriate laws, regulations and safe practices that apply to these products, equipment that is connected to these products and materials that may be used with these products.

It is the responsibility of the user to insure that proper training of operators has been performed and a safe work environment is provided.

Our company is proud to provide a variety of products to the abrasive blasting industry, and we have confidence that the professionals in our industry will utilize their knowledge and expertise in the safe efficient use of these products.

DEFINITION OF TERMS USED IN THIS MANUAL

Abrasive (also known as “media”): granular material used for blasting a surface.

Blow down (also known as “depressurize”): to expulse air automatically or manually from a pressurized vessel.

Control Handle: mandatory remote-control device used to start and stop the blaster.

Depressurize (also known as “blow down”): to expulse air automatically or manually from a pressurized vessel.

Pressure Hold System (also known as “manual blow-down system”): blasting system in which the pressure vessel stays pressurized when the control handle is released.

Pressure Release System (also known as “automatic blow-down system”): blasting system in which the pressure vessel is automatically depressurized when the control handle is released.

Pressure Vessel: enclosed section of the blaster filled with pressurized air and abrasive during blasting operations.

Pressurize: to fill the pressure vessel with compressed air.

Properly Trained Person: a person who has successfully passed a training course in sandblasting pertaining mainly to the safe operation of stationary or portable Abrasive Blasters with capacities ranging from 1.5 ft³ to 6.5 ft³ and who has read this entire manual and understands it.

Silica : hazardous substance found in many naturally occurring abrasives. Dust produced by blasting with abrasives containing silica can cause respiratory diseases.

NOTE: Abrasives containing silica must NEVER be used in any blasting situation. Even if respiratory protective equipment is used, the resulting dust can cause respiratory disease.

SAFETY SYMBOLS

The safety symbols below are designed to ensure the safety and protection of the Abrasive Blaster operator and of anyone else nearby. The explanations provided apply to sandblasting equipment.



OR



WARNING : This symbol indicates a potentially dangerous situation that could result in serious injury or death if the instructions related to the symbol are not carried out. Throughout the manual, this warning triangle will appear to denote instructions requiring special attention.



OR



DANGER : This symbol indicates a potentially dangerous situation that WILL result in serious injury or death if the instructions related to the symbol are not carried out. Throughout the manual, this warning triangle will appear to denote instructions requiring special attention.



SYSTEM OVERVIEW

SANDBLAST BOOTH STRUCTURE - AIR CIRCULATION

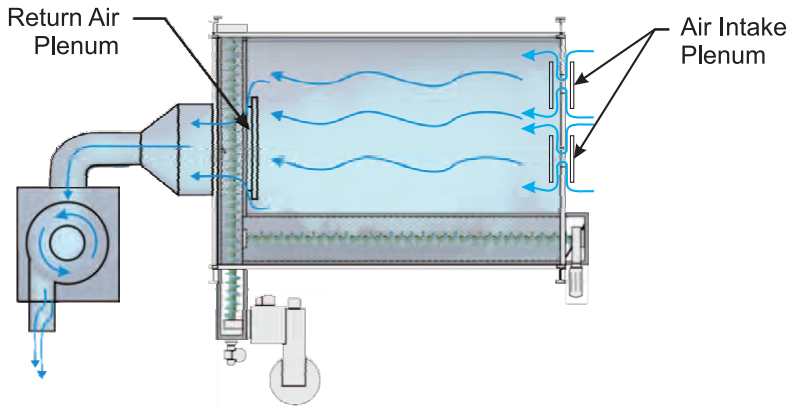

The suction fan, through the dust collector and conduit network, creates a negative pressure of 1/2 "w.g. (Nominal) at one end of the blowing room. This causes the outside air to be sucked through the air inlets at the opposite end of the chamber and generates a cross-flow airflow. The exhaust outlet is diverted to allow only the transport of dust-laden air. The inputs and outputs are proportionally sized to ensure adequate volume and airflows.

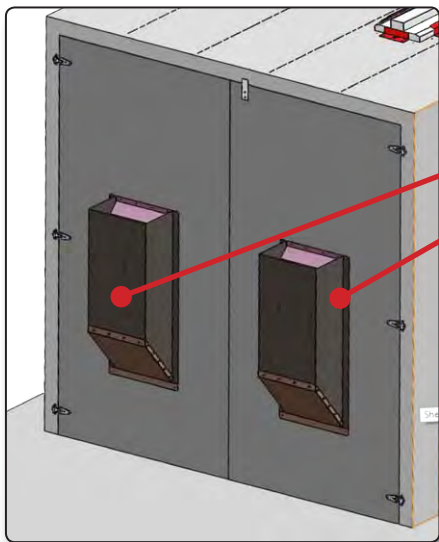

INLET PLENUMS

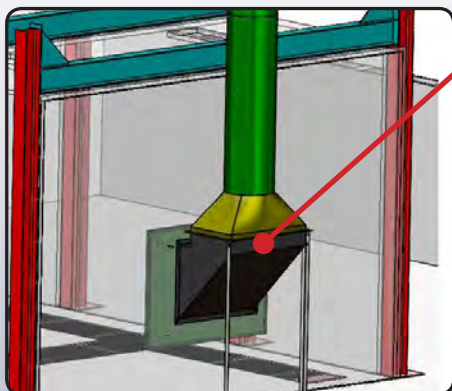

SOLID BACK SANDBLAST BOOTH

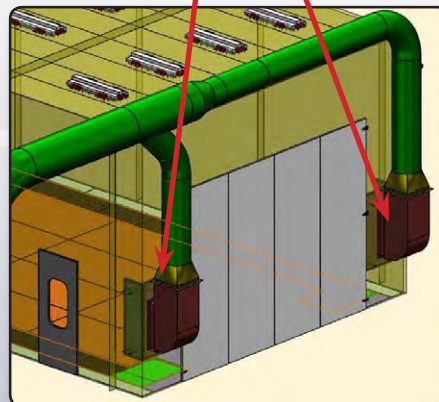

DRIVE THROUGH SANDBLAST BOOTH

ABRASIVE AND CLEANING SYSTEMS - CONFIGURATIONS

The steel grids cover the screw conveyors. These conveyors carry the media to a rotating screen basket that separates the media from the larger debris. The media coming out of the rotary basket feeds a vertical bucket elevator. Once raised, the media falls into an air wash system. This air washing system extracts dust from the media drop which continues its way to the storage hopper. The storage hopper feeds the media into the pressure vessel as used by the operator and so on.

RECOVERY AREA

Many configurations are available, see your custom drawing provided by ISTblast to meet your needs.

SOME EXAMPLES OF CONFIGURATIONS:

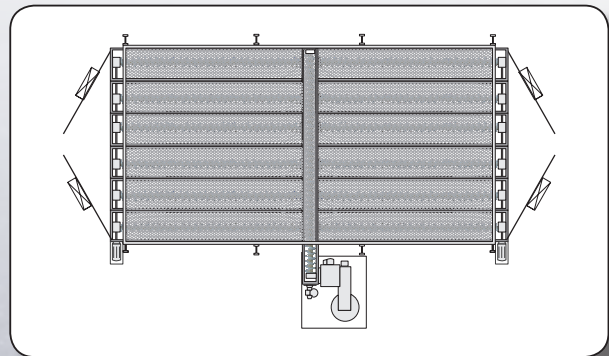
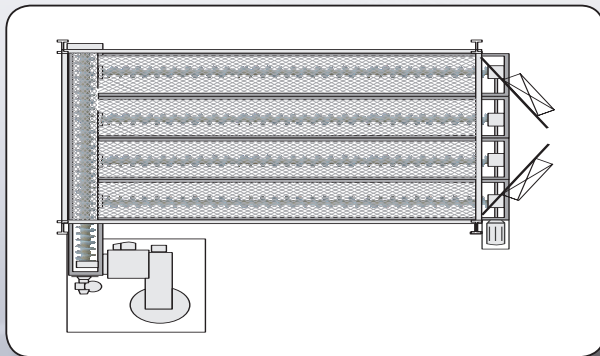
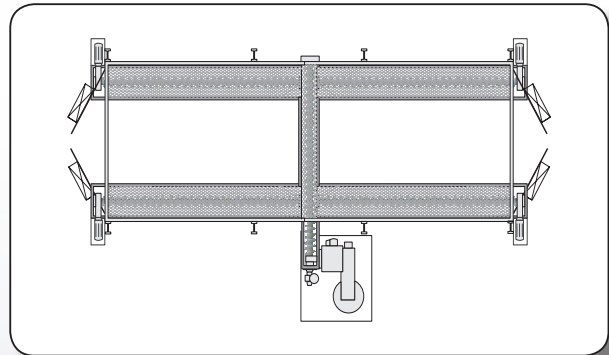
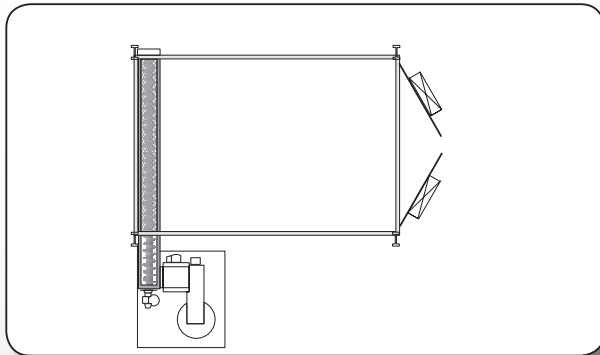
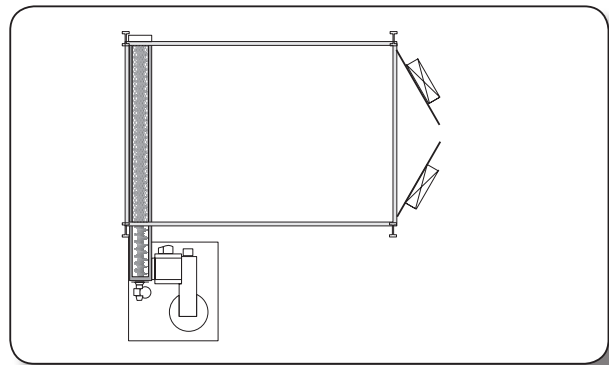
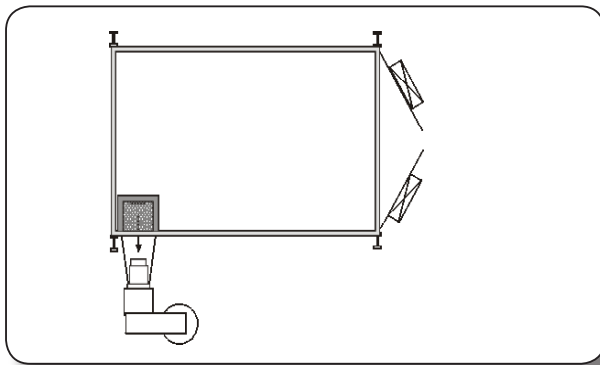

ABRASIVE AND CLEANING SYSTEMS - SCREW CONVEYOR

LONGITUDINAL

The longitudinal conveyor modules on the floor consist of a 10 ga steel screw structure. The screw is supported by a suspension bearing..

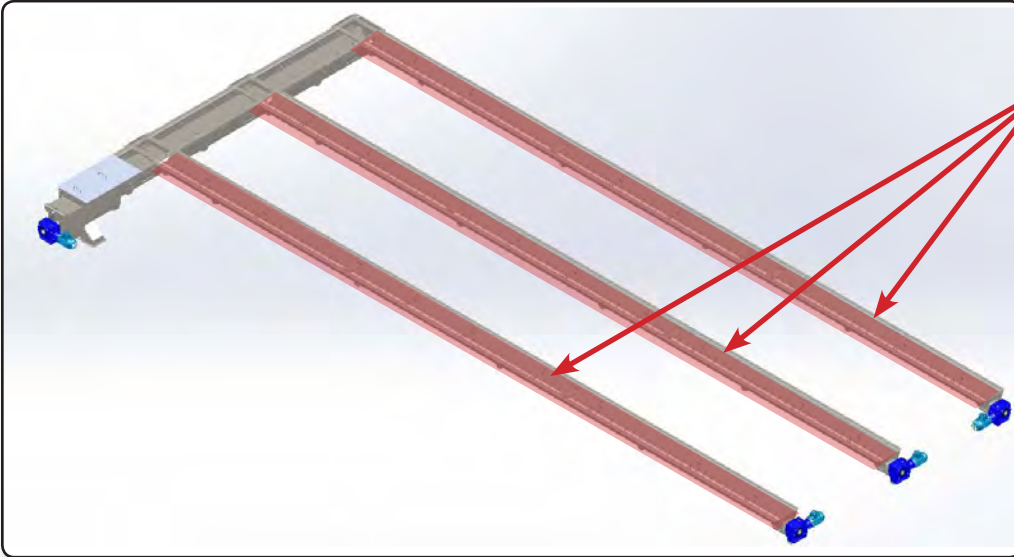

The dimensions and the number of units depend on the chosen configuration.

CROSSING

The transverse screw conveyor modules on the floor consist of a 10 ga steel screw structure. The screw is supported by hanger bearings. The transverse screw conveyor collects the overflow from the longitudinal screw conveyor.

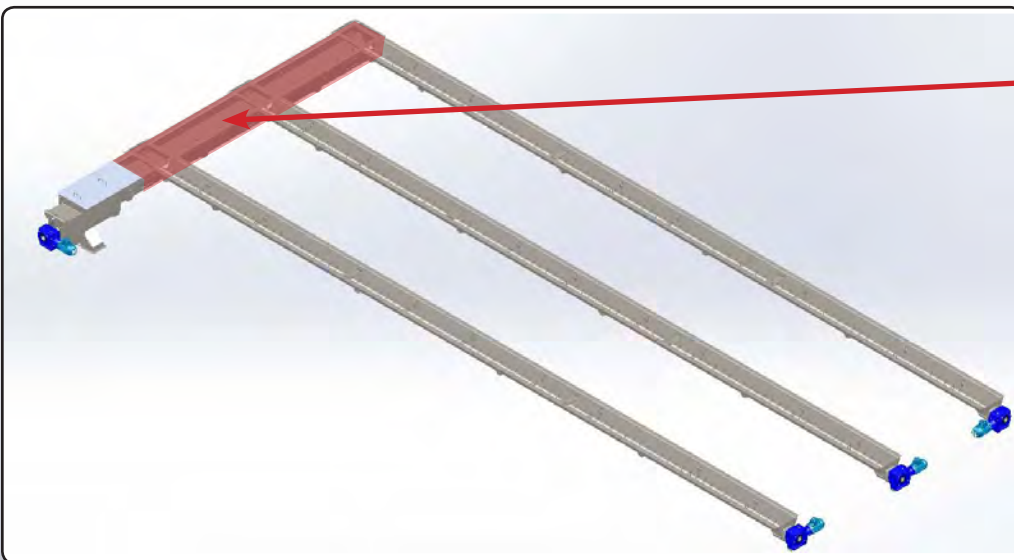

The dimensions and the number of units depend on the chosen configuration.

ABRASIVE MEDIA RECOVERY SYSTEM - OVERVIEW

Worn media are collected by the screw conveyor system incorporated into the floor and conveyed through a perforated screen drum, where particles with higher density are diverted into a rejection drum, to reach the air wash media separator. The air wash separates media based on its density and return only media still in good working condition back to the storage hopper.

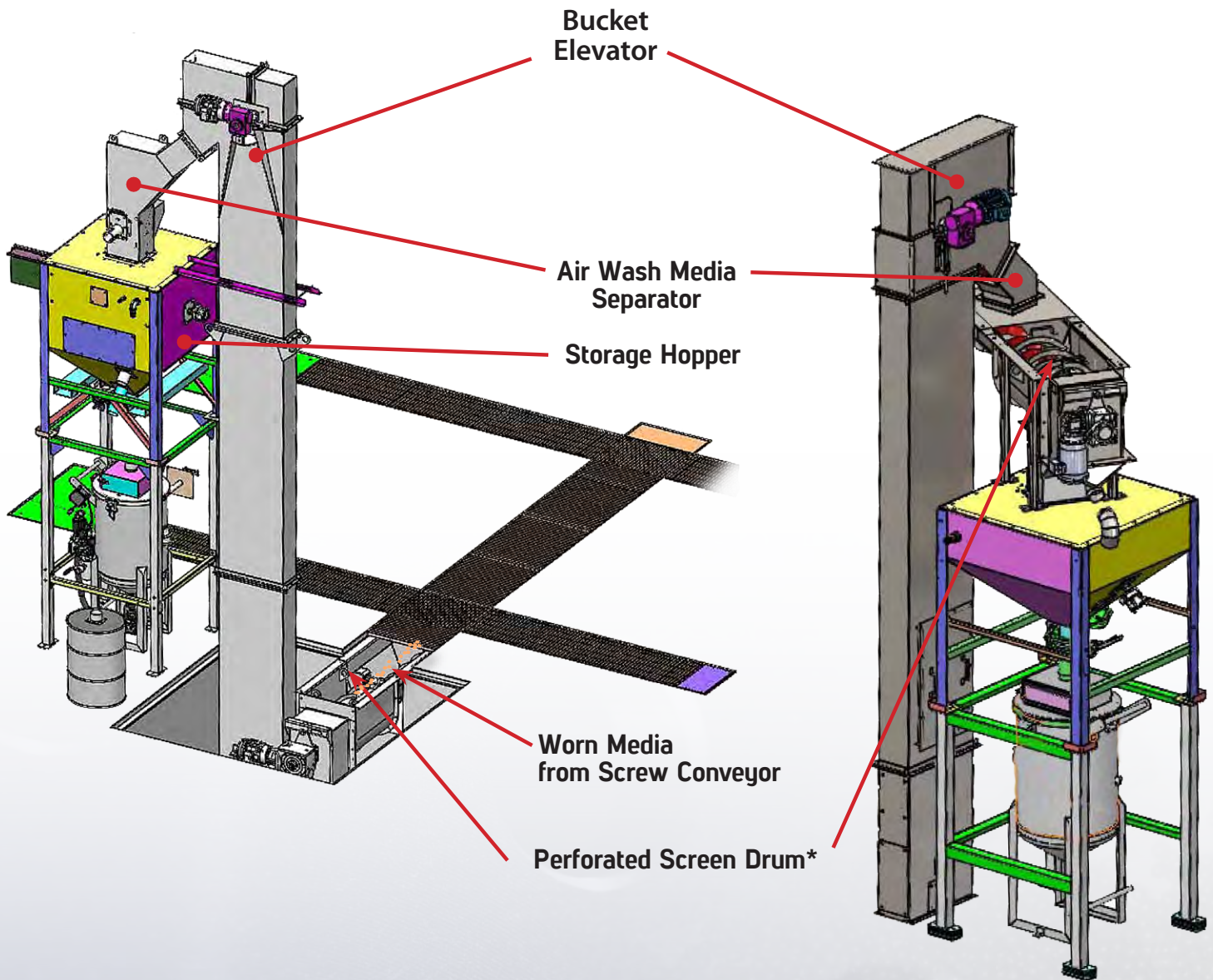

*When excavation is not permitted or is limited in terms of deepness, the perforated screen drum is located between the exit of the bucket elevator and the entrance of the air wash media separator.

ABRASIVE AND CLEANING SYSTEMS - PERFORATED ROTARY DRUM

A rotating screen drum is installed at the end of the transverse screw conveyor to filter out larger debris that could have contaminated the media. The rotating drum screen consists of a 11 gauge steel sheet with 3/16" diameter holes. The body of the rotating basket is 30" long by 14" diameter. There is a welded helix inside and outside the body.

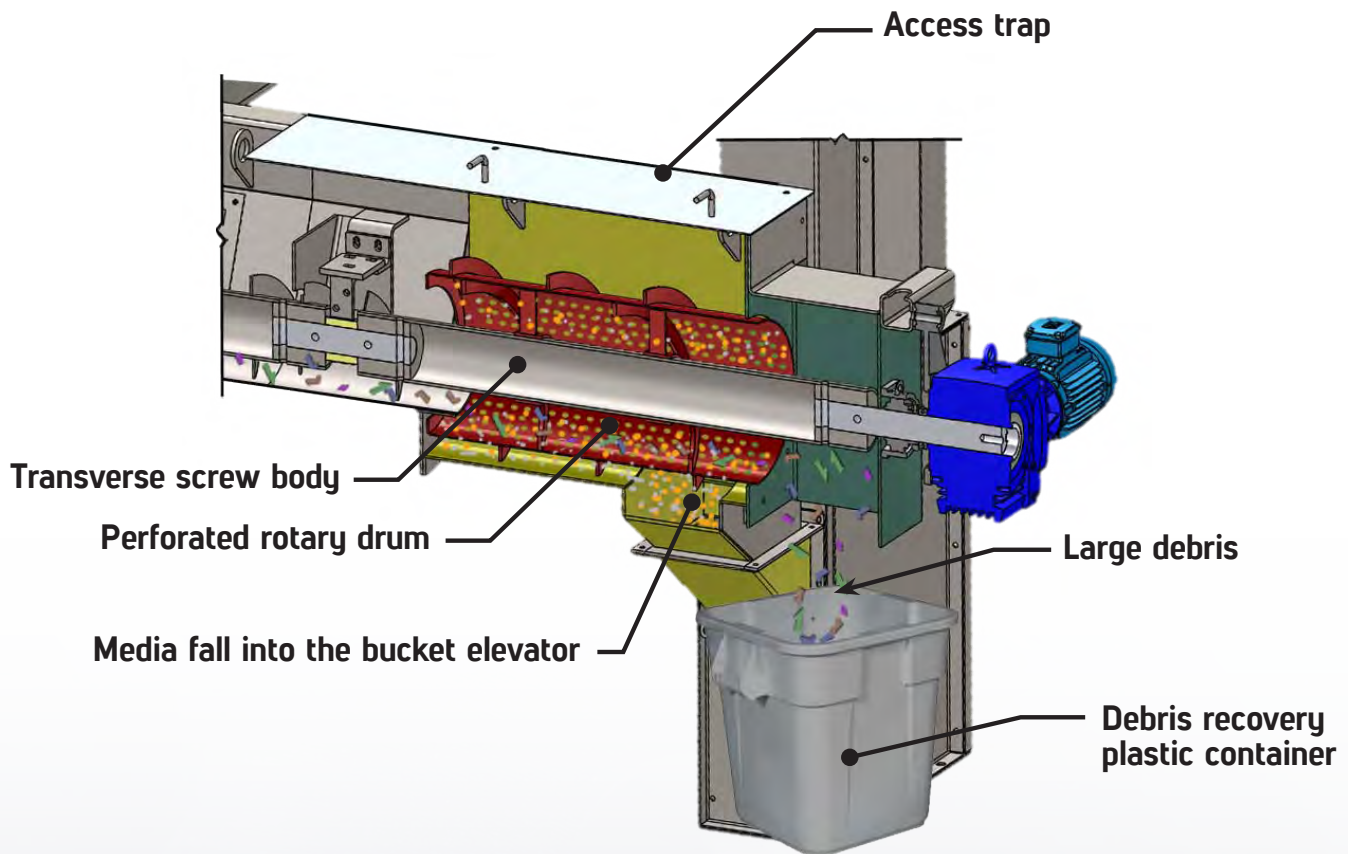



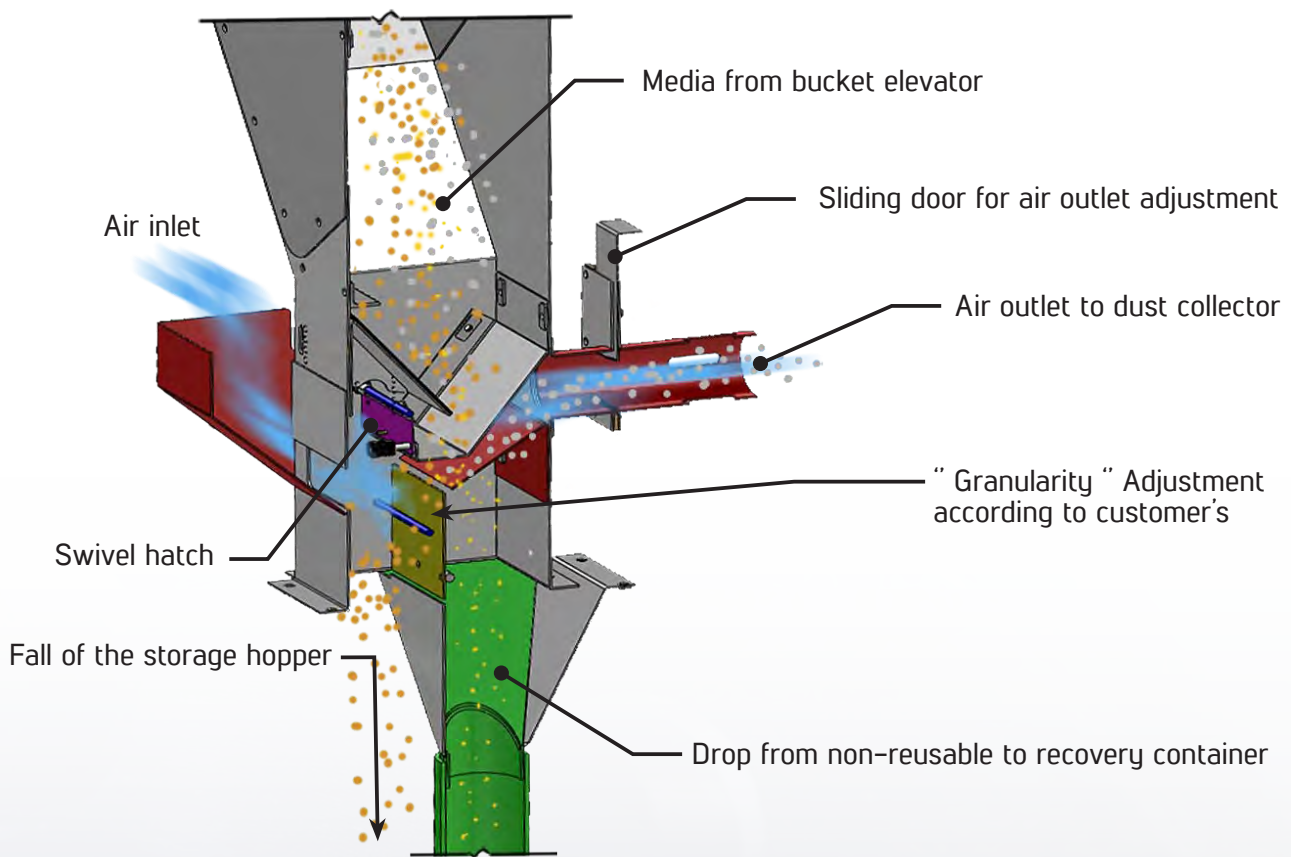

LEGEND	
	Media
	Dust
	Debris

ABRASIVE RECOVERY SYSTEMS - AIR SEPARATION SYSTEM

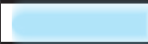
Reusable media, dust and non-reusable media fall from the bucket elevator into the air separation system consisting of several deflectors. A flow of air is created allowing to extract the dust from the mix. The reusable media is directed to the storage hopper to fill the sandblasting pot. A selection of granularity is made possible by an internal door, that controls the velocity of the fall. The non-reusable media is lighter than the reusable media but heavier than the dust, so it can be directed into the non-reusable drop which is ultimately connected to a recovery barrel.



LEGEND	
	Air
	Reusable media
	Non-reusable media
	Dust

ABRASIVE MEDIA RECOVERY SYSTEM - AIR SEPARATION SYSTEM (CONT'D)

The adjustment of the air separator to fine-tune the selection of the granularity is made possible by the external lever located on the side of the assembly.

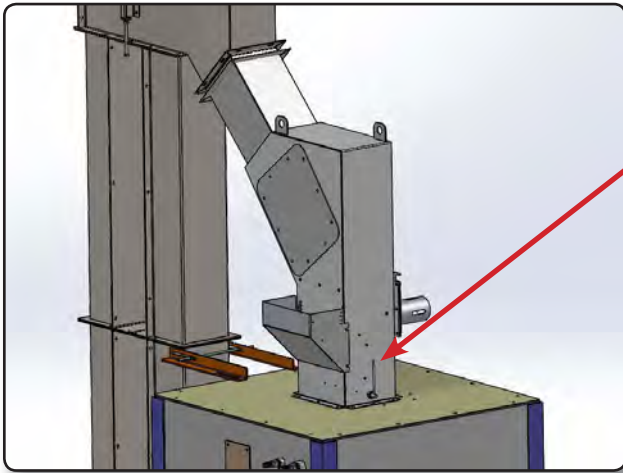

Adjustment deflector to increase or decrease the airflow speed

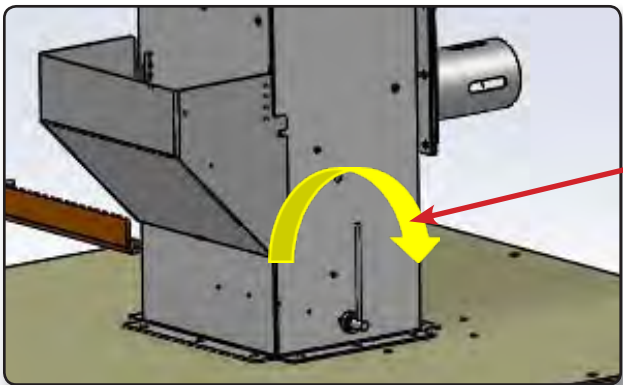

A wider range of media granularity will fall into the storage hopper.

The media mixture will include fine particles

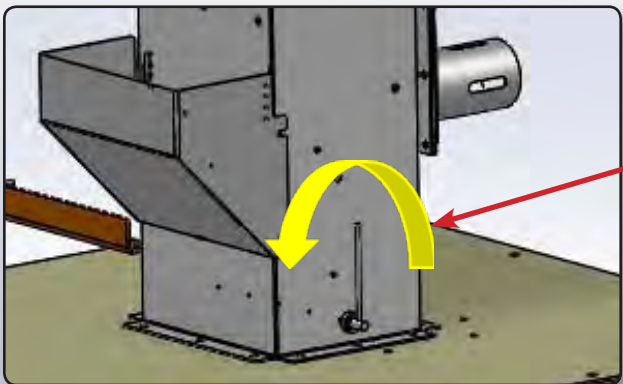

A smaller range of media granularity will fall into the storage hopper.

The reused media will have fewer fine particles

REMOTE CONTROL BOXE FOR PRESSURIZATION/DEPRESSURIZATION & BLAST ON/AIR (LOCATED INSIDE THE SANDBLAST BOOTH)

A PRESSURIZED/DEPRESSURIZED VESSEL SWITCH

The depressurization switch located inside the blast booth allows the operator to fill up its pressure pot without the hassle of leaving the booth and taking off the safety equipment.

This switch controls the AV-176 Combo Air Valve to release the pressure inside the blast pot, allowing the plunger to fall and let the blast media contained into the recovery hopper to fill up the pot.

B BLAST ON/AIR ONLY SWITCH

A pneumatic cut-off switch is provided to turn your blast hose into a powerful air blower producing high velocity compressed air to blow dust off of the workpiece and to clean the floor by blowing abrasive media remains towards the nearest floor recovery hopper. This switch controls the opening and closing of the abrasive metering valve.

When sandblasting is completed, the operator simply places the switch to the "AIR ONLY" position, stopping the flow of abrasive. The air valve remains open so that only high-speed compressed air flows through the nozzle.

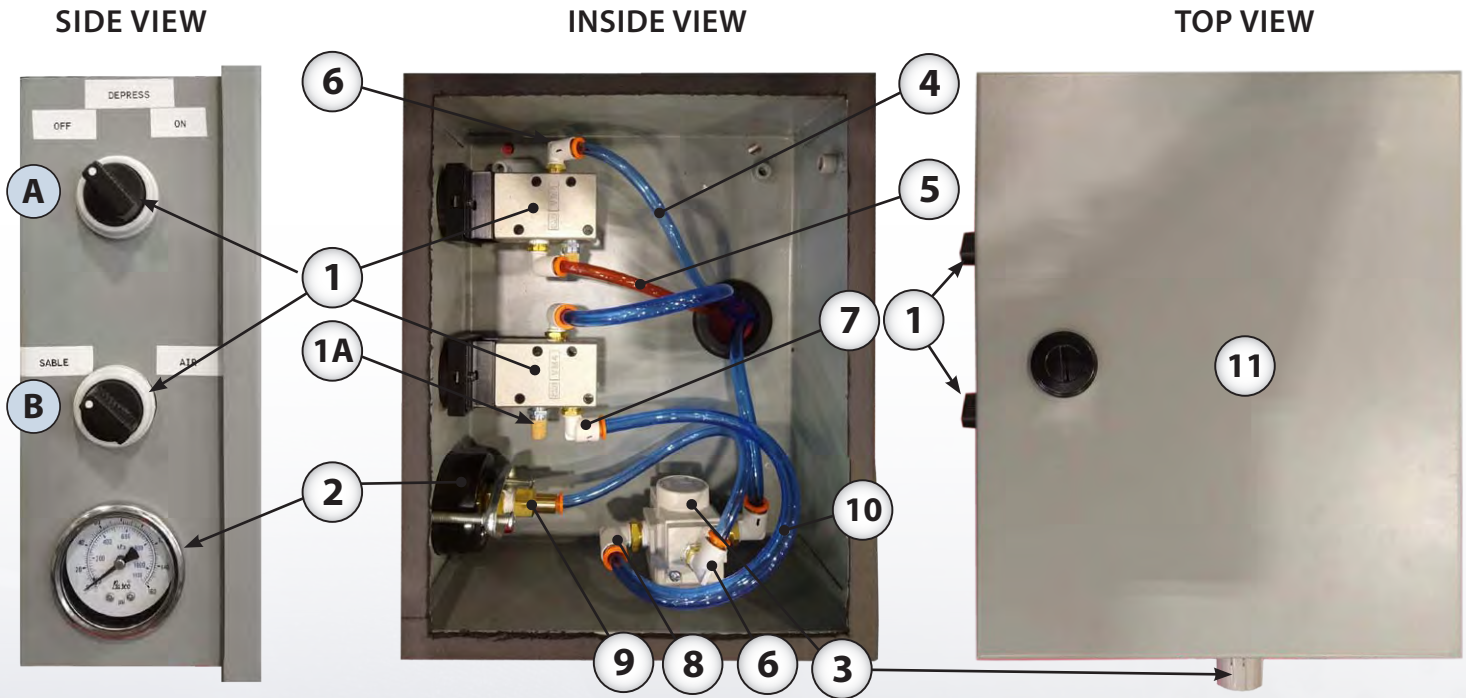

ID	Part #	Description
1	920062	PNEUMATIC SWITCH
1A	608284	MUFFLER
2	740013	1/8" PRESSURE GAUGE
3	608015	1/4" PRESSURE REGULATOR

ID	Part #	Description
6	324561	90° 1/8" MTP - 1/4" T. PUSH-IN FITTING
7	740009	90° 1/8" MTP - 5/16" T. PUSH-IN FITTING
8	908815	90° 1/4" MTP - 5/16" T. PUSH-IN FITTING
9	324572	1/8" MTP - 1/4" T. PUSH-IN FITTING
10	919584	5/16" BLUE POLYESTER TUBE
11	776130	10" H x 8" L x 4" D JUNCTION BOX

PRESSURE VESSEL - CONTROL VALVES

ABRASIVE METERING VALVES



AR7+A7 MEDIA METERING VALVE ASS'Y

The AR7 abrasive metering valve can control the flow of abrasive that falls into the blast stream by the use of a crank. The pneumatic actuating function is controlled by the A7 actuator separately. Usually close, the A7 actuator opens the orifice and let the blast media flow through when the blast flow is activated by the operator.

AIR VALVES



AV-176 COMBO VALVE

The AV-176 valve is a one-piece combination inlet and outlet valve utilized to control compressed air supply into and out of the blast pot.

A single piston assembly is utilized to both open and close the valve's inlet and outlet sections.



AV-186 AIR VALVE

The AV-186 is a diaphragm air valve that controls the air flow of the jet stream when the vessel is pressurized. By default, this valve is closed. When the operator activates the remote control handle, the AV-186 Air Valve opens and let the compressed air flow through the jet stream, where it mixes up with the media and then propels it at high velocity on the workpiece.

FOR PARTS DETAILS VALVES, SEE SANDBLASTING PRESSURE POT INSTRUCTION MANUAL.

CHECKING INSTALLATION

1. Check motor rotation on dust collectors as per arrow indicators placed on each fan.
2. Check that the emergency pull and door security options work properly.
3. Check that the pulse controller for the blast room dust collector activates solenoides on pulsation system (see manual DCM 2,000-50,000).
4. Install the hose blast nozzle and blast control handle.
5. Check that all pipe and hose connections are tightly fastened and air tight.
6. Check that all electrical box covers are securely installed.
7. Check that the dust drum (option) under the dust collector is sitting firmly and is center.
8. Start the dust collector.

PRESSURE VESSEL - ABRASIVE BLAST LINE



SANDBLAST HOSE

The sandblast hose, which transmits compressed air and media to the blast nozzle, has an internal diameter of 1¼" and an outside diameter of 2 5/32". It weighs 60 pounds for each 50' length. The hose is rated for a working pressure of 175 psig. The hose fitting is ¼" thick, rubber impregnated with carbon black for static dissipation. It is equipped with quick and light aluminum couplings that mount outside and incorporate self-locking safety wires. Fifty (50) feet of sandblast hose and control lines are supplied with each blasting machine. An optional 12 ½" "whip" hose is available at the last section to provide the user with more flexibility and less weight to carry on his back.



SANDBLAST NOZZLE

A double venturi nozzle will be supplied with the sandblasting machine. The nozzles are made of the highest quality materials and designed for a long service life. The nozzle is connected to the sandblast hose with an externally mounted nylon nozzle holder.



OPERATOR REMOTE CONTROLS

The remote controls are pneumatic type, and include a normally closed inlet valve and a normally open outlet valve. The air pressure opens the inlet valve and closes the outlet valve to begin the sanding process. In the event of loss of air pressure on the valves, the springs return the valves to their normal position.

If your sandblast hose is 75 feet or more, the remote control should be electric.

ABOUT THE REMOTE CONTROL SYSTEMS

An electric or pneumatic remote control system (also called "Deadman") must always be used with a sandblasting pot to start and stop blasting.



Electrical: On the sandblasting pot, the remote control handle must be connected to the female socket with rotating latch of the blasting pot. A 12V DC power source (12V battery or optional 120 V AC to 12 V DC converter) must be connected to the male latch connector.



Pneumatic: The dual remote control hose must be connected to the blasting pot using supplied threaded or quick disconnect couplings. The use of pneumatic remote control systems is not recommended with sandblast hoses over 75 feet.

HMI (HUMAN MACHINE INTERFACE)
FOR SCREW SANDBLASTING ROOM

HMI



FATEK HMI INTERFACE



SCREEN SAVER MODE

ISTblast screen saver will display after 4 minutes of inactivity.
When touching it anywhere, the menu will display again.



HMI (HUMAN MACHINE INTERFACE) - MAIN MENU



By pressing the "Menu" button (5), the buttons from 1 to 4 will appear above

1	AUTOMATIC: Access the Automatic Mode Operation Screen
2	ALARMS: Display all ongoing and fixed alarm notifications
3	MANUAL: Access the Manual Mode Operation Screen
4	PARAMETERS: access to Language and Timer adjustments (requires a password)
5	MENU: Access all available menus

1 AUTOMATIC MODE

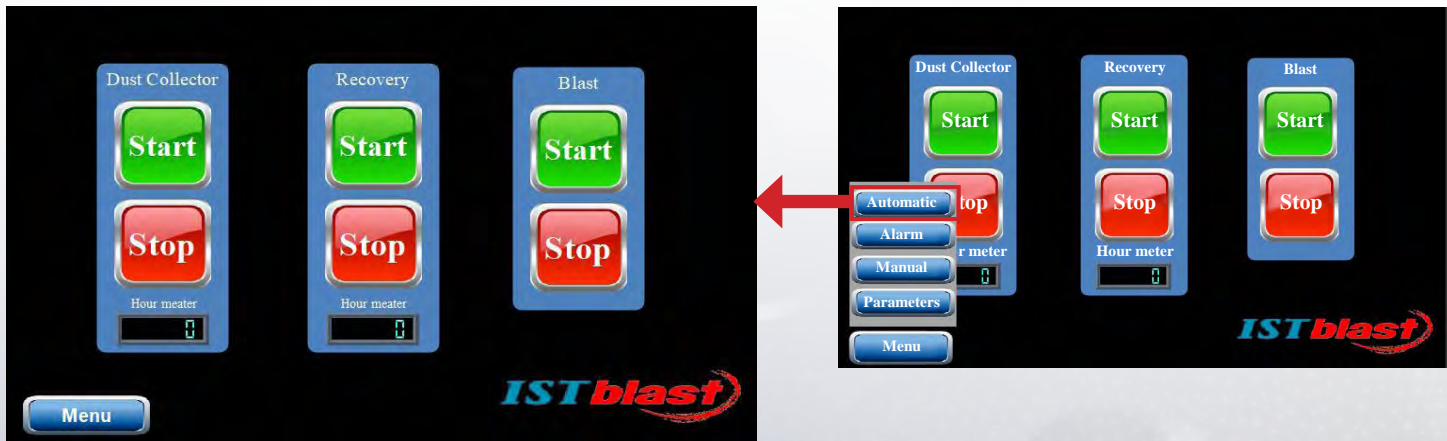

THE SYSTEM WILL AUTOMATICALLY LOCK ITSELF AFER ONE MINUTE OF INACTIVITY.

HMI - (HUMAN MACHINE INTERFACE) - USER ACCESS

2 ALARM

Date	Trigger	Recovery	Message
20/08/06	09:08:35	09:13:33	Recovery System Time Out
20/08/06	09:08:35		!! FIRE !!
20/08/06	09:08:35		Hi Level Air Particles
20/08/06	09:08:35		Overload Longitudinal Screw #8
20/08/06	09:08:35		Overload Longitudinal Screw #7
20/08/06	09:08:35		Overload Longitudinal Screw #6
20/08/06	09:08:35		Overload Longitudinal Screw #5
20/08/06	09:08:35		Overload Longitudinal Screw #4
20/08/06	09:08:35		Overload Longitudinal Screw #3
20/08/06	09:08:35		Overload Longitudinal Screw #2
20/08/06	09:08:35		Overload Longitudinal Screw #1
20/08/06	09:08:35		Overload Cross Screw



- | | |
|---|--|
| 1 | Error messages in green have been resolved |
| 2 | Error messages in red are in progress |
| 3 | Use scroll bar to scroll the page up/down |
| 4 | Press "Alarm" again to reset all alarms (if required)* |
| 5 | Return to menu |

If any default occurs, a sentence in red *indicating the nature of the alarm will be displayed while scrolling at the top of the main screen. When the fault is resolved, the sentence will disappear and will be displayed in green in the history of the alarm panel.

3 MANUAL MODE

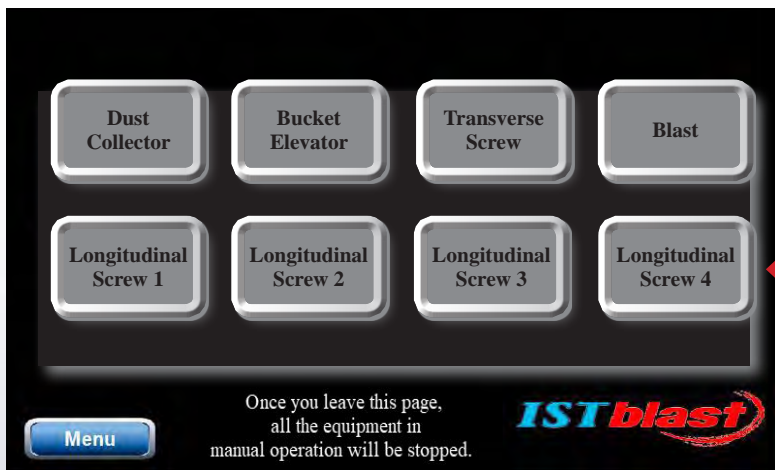

Press the grey button to activate a system. The case will turn green while the system starts. A message will display under the buttons: "Once you leave this page, all the equipment in manual operation will be stopped"

HMI (HUMAN MACHINE INTERFACE) - ADMIN. ACCESS

4 PARAMETERS

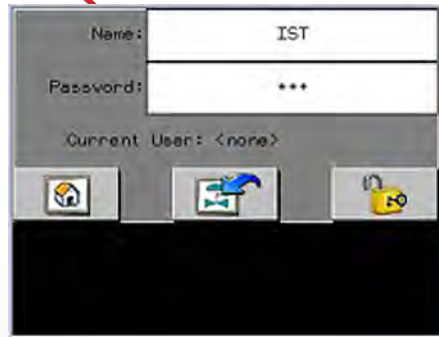

Enter your Name & Password

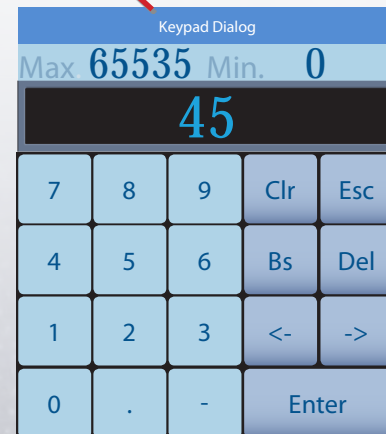

TOUCH ANY OF THESE CONTROL BOXES TO ADJUST VALUE BY USING THE POPUP KEYPAD



MAINTENANCE

BOOTH ENCLOSURE

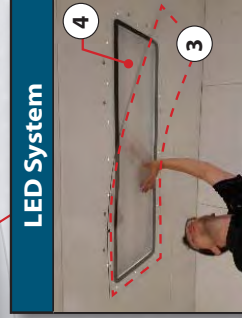
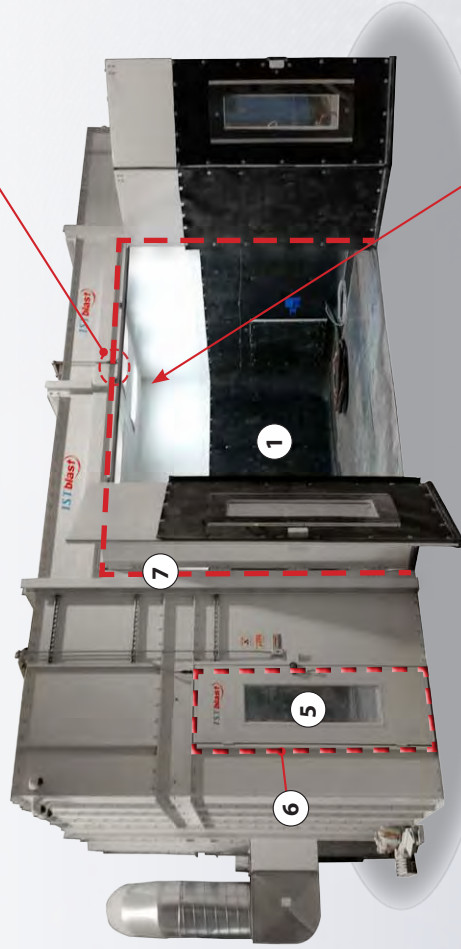

WEEKLY MAINTENANCE

- 1. Rubber Lining (1):** Check for wear or deterioration of blast room rubber lining and replace when needed.
- 2. Light System:** Clean frequently Light Lexan Cover (3) and replace when needed.
- 3. Personal Men Door:** Clean frequently Door Lexan Window (4) and replace when needed. Make sure Door Seal (5) is airtight and replace when needed.

REPLACE WHEN NEEDED

DESCRIPTION	PART #
Rubber Lining (sold by square foot) (1)	618330
Door Safety Switch (2)	917586
Lexan Cover for Light (3)	D900183S02
LED Light Fixture (4)	617193
Lexan Door Window (5)	613032
Door Seal (6) 1 ³ / ₄ " x 5 ¹ / ₈ " (12.5 ft)	618438
Main Door Seal (7) 1 ¹ / ₄ " x 7 ⁷ / ₈ " (45 ft)	618349



PREVENTIVE MAINTENANCE SCHEDULE

SANDBLASTING EQUIPMENT



DAILY MAINTENANCE & OPERATION

- Inspect Personal Protective Equipment (PPE) ①. Service or replace when needed.
- Arrange blast hose ⑤ in a way to avoid overlaps and steep curves.

WEEKLY MAINTENANCE

- Inspect and service remote control handle and hose ②.
- Inspect blast nozzle ③ and replace when needed.
- Inspect “whip” blast hose (the last section near the nozzle) ④ for leaks and replace when needed. The wall of the whip hose is thinner than other sections to facilitate handling, but it wears out faster.

MONTHLY MAINTENANCE

- Inspect blast hose ⑤, couplings ⑥ and gaskets for soft spots and premature wear. Replace when needed.
- Inspect breathing air supply hose ⑦, couplings and gaskets for soft spots and premature wear. Replace when needed.

REPLACE WHEN NEEDED

- Refer to Nozzle, Hose, and Coupling Selection Guide.

SCREW CONVEYOR SYSTEM - PREVENTIVE MAINTENANCE SCHEDULE

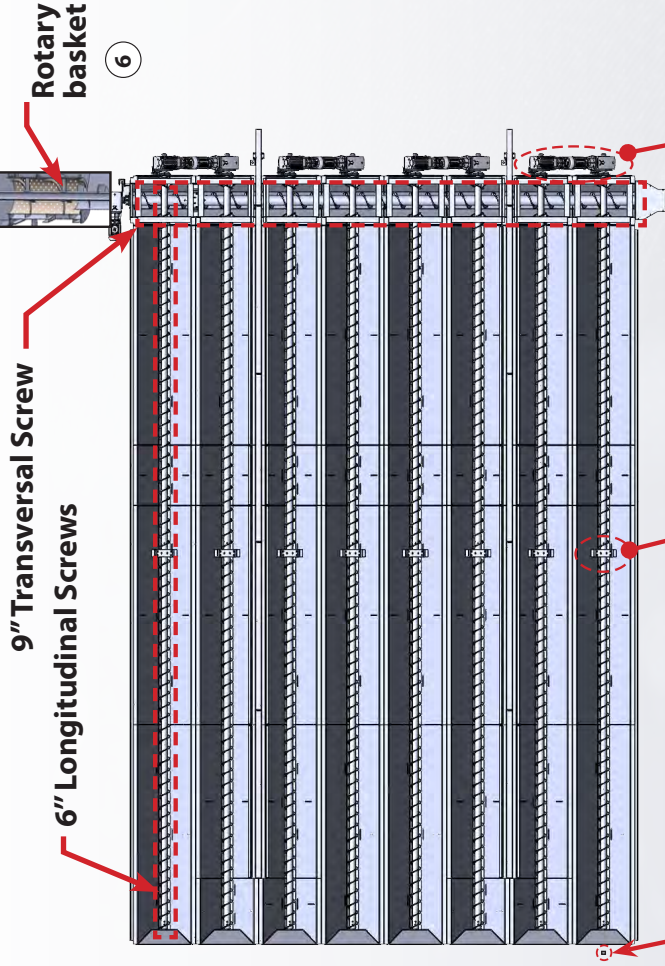

MONTHLY

- Lubricate **Ball Bearings** ④ and **Thrust Roller Bearings** ⑤
- Refer to name plate for oil type and volume required.
- Empty debris basket from **perforated screen drum** ⑥

EVERY 6 MONTHS

- Inspect every **Hanger Bearings** ① and **Coupling Shafts** ② for signs of wear. Both parts are self-lubricating and maintenance free. Replace when you notice signs of wear and/or when you hear a repetitive screeching noise.

EVERY 2,000 HOURS OF OPERATION

- Change oil on gear motor ③ Refer to name plate for oil type and volume required.

REPLACE WHEN NEEDED

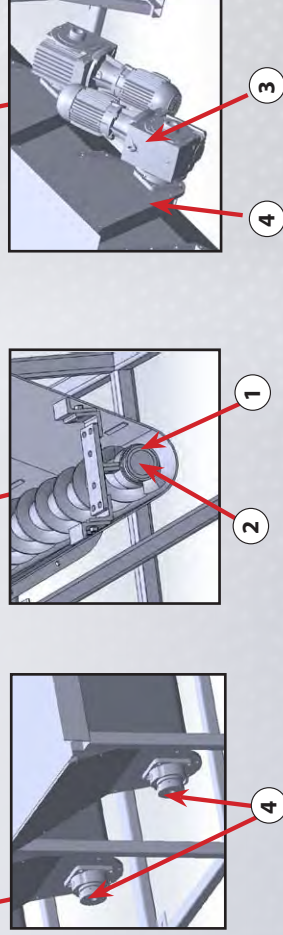

Roller Bearings



Ball Bearings

DESCRIPTION	PART #
Hanger Bearing ①	919729
Coupling Shaft ②	900404
Gear Motor 2 hp / 480 V ③	916555
Gear Motor 2 hp / 600 V ③	916556
Flange-Mount Ball Bearing ④	900406
Thrust Roller Bearing ⑤	916557

④ Bearings can vary from system to system. Refer to the picture to identify the part that is on your system.



SCREW CONVEYOR SYSTEM - HANGER BEARING REPLACEMENT

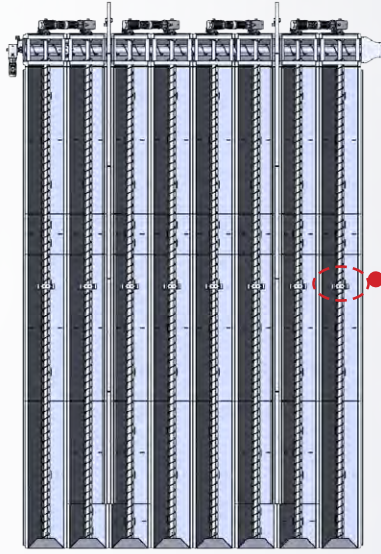

Hanger Bearing & Coupling Shaft

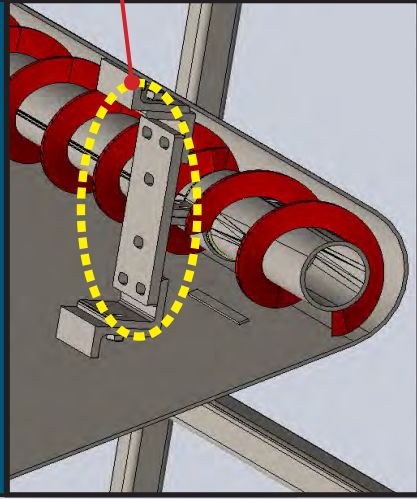

1. Remove the holding plate ① & "J" brackets ②.
2. Remove the split hanger bearing ④.
3. Clean the surface of the coupling shaft ③ using a fine emery cloth, as necessary.
4. Put a new hanger bearing ④ in place. Use only original "Martin" cast iron oil impregnated.

You don't need to change the coupling shaft unless it has signs of wear.

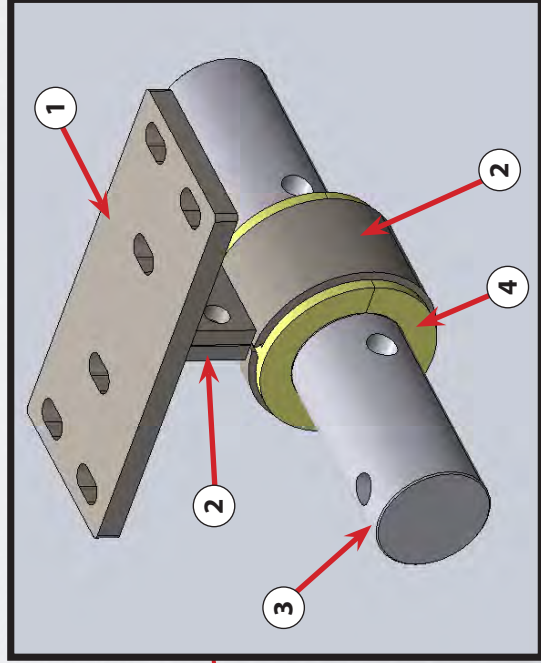

PREVENTIVE MAINTENANCE SCHEDULE

TENSIONING RUBBER BELT

- The rubber belt **3** must be tensioned 1 month after startup, and periodically thereafter.
- To adjust the tension on the belt, turn the adjustment screw **4** clockwise to increase tension or counterclockwise to release tension. The tension must be equal on both sides of the bucket elevator.
- Inspect the belt and the buckets through the service trap door **5**, and adjust tension accordingly.

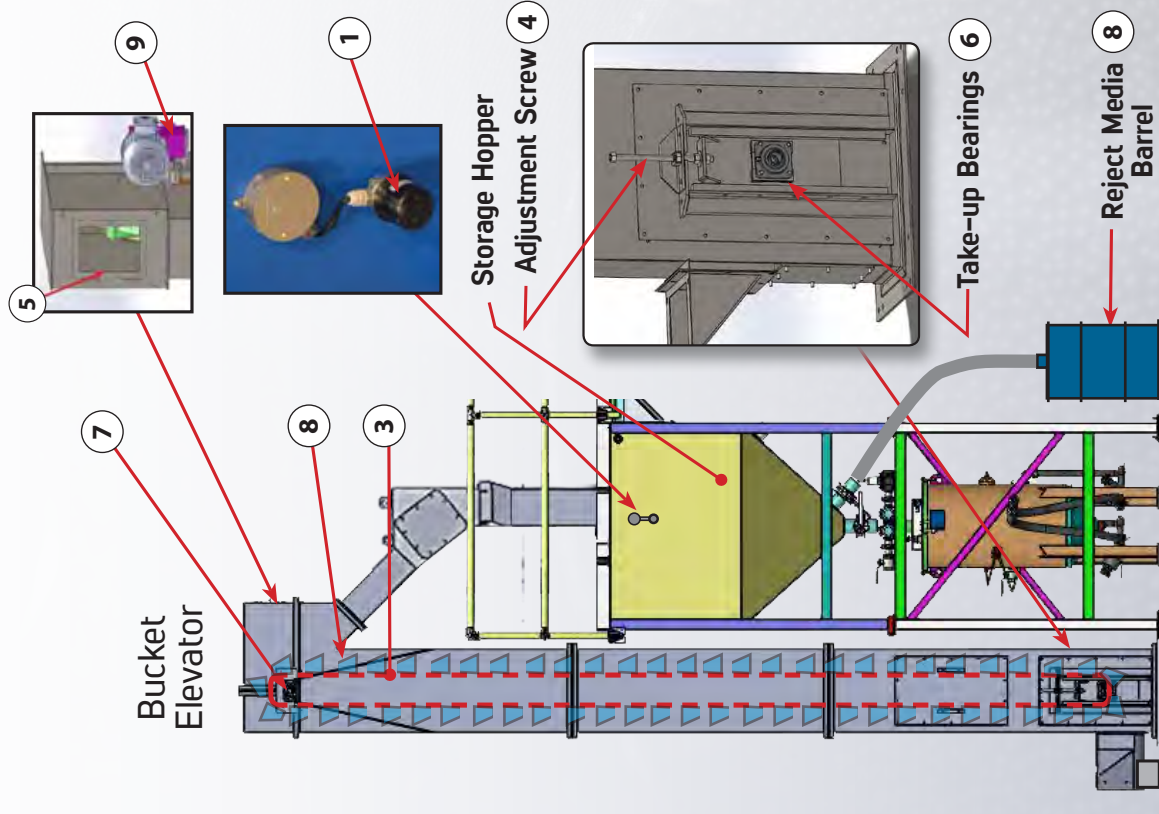

1 MONTH AFTER STARTUP

- Adjust tension on rubber belt **3**.

MONTHLY

- Lubricate Take-Up Bearings **6** and Pillow Block Bearing **7** using multipurpose gear box grease. Replace when worn.
- Check level of rejected media barrel **8** and empty regularly.

EVERY 2,000 HOURS OF OPERATION

- Change oil on gear motors. Refer to name plate for oil type and volume required. Replace when worn.
- Inspect the belt and the buckets through the service trap door **5**, and adjust tension accordingly. Replace belt or buckets when you notice signs of wear.

REPLACE WHEN REQUIRED

DESCRIPTION	PART NB.
Take-up roller bearing on the lift shaft 6	916558
Roller bearing on the shaft at the head of the elevator 7	924980

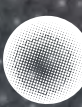

TROUBLESHOOTING

TYPE OF FAILURE	POSSIBLE CAUSE	SOLUTION
ABRASIVE NOT FLOWING DURING BLASTING (AIR ONLY)	The Pressure vessel is empty.	Depressurize the pressure vessel, add media and check again.
	The «Blast On / Air Only Switch» (if equipped) is set to «Air Only» mode and is preventing the abrasive from flowing.	Turn the switch to «Blast On» allowing the media regulator to release media in the push line.
	The Abrasive Regulator is closed or not properly adjusted.	Turn the adjustment crank counterclockwise, half turn at the time, to allow more media in the mix.
	There is a blockage in the Abrasive Regulator.	Have a second qualified person to assist. Activate the control handle and ask a qualified person to alternate open/close the «choke valve» for 3-5 times until the obstruction is released. Minor obstructions, such as paint chips, a bit of wet abrasive or a piece of paper, will be forced through the Regulator and out of the nozzle. Turn the Regulator back to the required blast setting and check if the obstruction has been removed. If the blockage persists, release the remote-control handle, depressurize the vessel and proceed to disassembling the Regulator and removing the blockage manually.
	The pressurized vessel has an air leak and the pressure inside the vessel is less than the one on the push line.	Check for air leaks (plunger seal, maintenance door, and/or quick-depress valve) and service your blast pot.
	The abrasive media is contaminated with humidity, which prevent it from flowing through the Regulator.	Empty your pressurized vessel from media, clean the reservoir through the maintenance door, and replace with new media. Consider servicing and/or adding air dryer and/or dessicant filter on your airline.
ABRASIVE STREAM TOO HEAVY OR THROBBING DURING BLASTING	Note : When Auto-depress systems first start up, they may throb for a while if there is an accumulation of abrasive in the blast hose from a previous operation. This is normal, and no corrective action is needed.	
	The Choke Valve is partially closed. The Abrasive Blaster should be operated ONLY with the Choke Valve fully open.	Open the Choke Valve and check again.
	The Abrasive Regulator needs adjustment.	Turn the adjustment crank clockwise to restrict media in the mix. If your unit is equipped with an Actuator that closes the Regulator when the unit is not blasting, be sure to adjust the Regulator only while blasting.
	The rubber tube inside the regulator is worn or ultimately pierced.	Disassemble the Regulator, clean any accumulation of media in it and change the rubber tube. If the rubber tube as a perforation, the media can flow freely in the Regulator and therefore can create wear on all the other inner mechanical parts. Proceed to a complete inspection of the push line before using the unit again.



**SAFETY
EQUIPMENT**

AIR BREATHING – PROTECTIVE EQUIPMENT FOR THE OPERATOR

Abrasive blasting operators are equipped with Personal Protective Equipment (PPE) and respiratory equipment (RPE) to ensure the user is protected from materials and the respiratory health risks associated with a blasting environment. IST is an authorized distributor of RPB Safety providing the best respirators and supplied air breathing systems available on the market for blasters. All PPE and RPE has been designed to comply with the National Institute of Occupational Safety and Health standards (NIOSH).



BLASTING RESPIRATORS

RPB's abrasive blasting line uses the latest available respiratory protection technology. The headtops are constructed with high-density polyethylene and manufactured in accordance with NIOSH certification. The respirators are equipped with a choice of six cape options that attach at the base of the headtop with its unique button and rubber seal design, ensuring no particulates enter the operators breathing zone. With multiple size options and adjustable padding system the headtop maintains a snug customizable fit that allows the respirator to move with the operator. With the headtop and breathing tubes weight evenly distributed across the head and shoulders this alleviates aches and strains on the user and reduces fatigue. All padding is machine washable for hygiene purposes.

The replaceable air inlet fitting is located at the back of the helmet in the center providing a streamlined airflow directing air to the breath zone and preventing the lens from fogging. All respirators feature a large visor window for uncompromised downward and peripheral vision and a set of replaceable tear off lenses for increased productivity. All parts are field replaceable and can be easily changed using the Allen key that sits neatly inside the padding.



Nova 3



Nova 2000

Breathing air supply hose available in 25', 50', and 100' lengths.



AVAILABLE WITH CHOICES OF CAPES

Nova 3



Nylon Respirator Cape



Leather Respirator Cape



Blast Jacket



Extra Length Leather Respirator Cape

Nova 2000



Nylon Respirator Cape



Leather Respirator Cape



Blast Jacket



Extra Length Leather Respirator Cape

BLASTING RESPIRATORS ACCESSORIES

IST provides an extensive range of safety essentials and supplied air and respirator accessories from RPB to advance the safety of your team and increase productivity.

CLIMATE CONTROL DEVICES

The climate control devices can increase or decrease incoming air to control the temperature of supply air to the blaster for optimal comfort. Hot tube can increase incoming air by up to 20 °F /± 11 °C while Cold tube can drop the temperature by up to 32 °F/± 18 °C (evaluated at 20 cfm).

The C40 Climate Control Device combines both heating and cooling features to an even wider range – max increase is 32 °F/ ± 18 °C and max drop is 52 °F/± 29 °C – all by the press of a lever. The operator can also adjust the flow of cool and hot air to fall between this supply range.

All climate control devices are located on the fresh air tube unit, within the range of the operator.

Their performance may vary depending on the temperature of the incoming air. They all carry NIOSH approvals as part of the complete system and with the same approval numbers.



Compatible with Nova 3 respirator only

AUXILIARY HEAD LIGHT

The LED L4 Light provides up to 650 lumens of concentrated light to the operator's field of view for increased vision and safety while blasting. The L4 mounts directly to the Nova 3 and it is powered by a lightweight battery pack attached to the blaster's belt. The battery lasts for up to 6 hours with a recharge time of 3-4 hours.

INTEGRATED COMMUNICATION SYSTEM

The Nova Talk is a wireless radio communication system that fits securely inside the headtop allowing operators to communicate effortlessly with team members. The simplicity of the push to talk system ensures this does not get in the way of the operator's safety. The Nova Talk is ideal for working in remote locations, like tanks, shipyards or any other areas that are difficult to access.



AIR MONITORING, FILTRATION, AND SUPPLY

RPB's supplied air range covers air filtration and gas monitoring. These systems help protect the operator from contaminants in the air supply and notify them when there is harmful gas detected by their supplied air source. Air filtration and gas monitoring systems can help you towards achieving Grade D breathing air.

For Grade D breathing air, please refer to OSHA standard 29 CFR 1910.134 and consult an external provider for reliable air quality results. It is the end user's responsibility to comply with the standard.

BREATHING AIR LINE FILTER



2 outlet Radex - intended use of up to 1 operator and 1 gas monitor

6 outlet Radex - intended use of up to 3 operators and 1 gas monitor

The Radex is a robust and versatile airline filter with exceptional filtration capacity. It connects straight to the air line and it removes moisture, odor and particulates to 0.5 micron from the compressed air stream, providing clean, breathable air to the operator. Its replaceable filter cartridge exceeds industry filtration standards.



Optional

GAS MONITOR

The GX4 gas monitor detects when gases are present in the air supply source, alerting when carbon monoxide, oxygen and hydrogen sulphide are at levels above/below grade D breathing requirements. Its smart device and cloud integration capabilities allow you to view your air quality from any device in real time. The system stores and logs up to two years' worth of data.



OPTIONAL ACCESSORIES



Carry case for field protection



Wall Bracket



Audible and strobe light Alarm systems





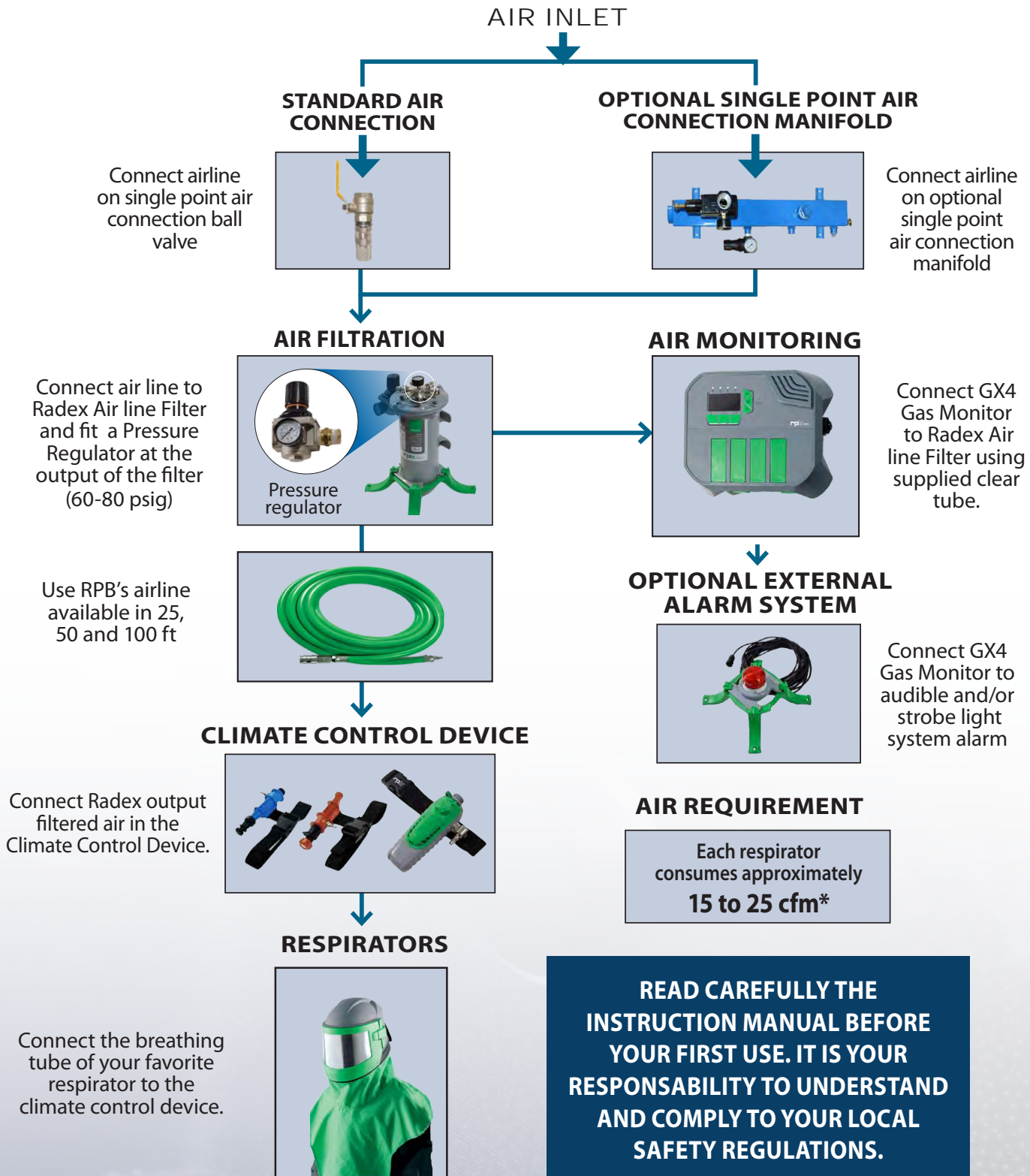



COMPLETE AIR BREATHING SYSTEM ASSEMBLY

The connection procedure below demonstrates how the RPB range helps to provide your operators with clean, safe breathing air that complies with NIOSH standards. All accessories are supplied with standard quick-connect fittings. Optional Schrader and RZ fittings are available upon request.



* Refer to Breathing Air Pressure Table in the instruction manual of your respirator. Air consumption may vary according factors like the climate, the flow device used and the total length of breathing air lines.

AIR FILTRATION AND MONITORING MAINTENANCE

EQUIPMENT	MAINTENANCE ROUTINE / FREQUENCY	SPARE PARTS
 Radex Air line Filter	<ul style="list-style-type: none"> ✓ Empty Drain Valve monthly* ✓ Replace Radex filter cartridges every 3 months or 400 working <p><i>*Not required if your Radex is equipped with Auto Drain Unit</i></p>	<div style="display: flex; justify-content: space-around;"> <div style="text-align: center;">  1 Replacement filter cartridge </div> <div style="text-align: center;">  2 Auto Drain Unit </div> </div>
 GX4 Gas Monitor	<ul style="list-style-type: none"> ✓ Pre-calibrated GX4 gas sensors have a 2-year shelf life. ✓ Sensor check on each cartridge is required monthly using Calibration Flow Regulator and Gas bottles. 	<div style="display: flex; flex-wrap: wrap; justify-content: space-around;"> <div style="text-align: center; width: 45%;">  3 Calibration Flow Regulator </div> <div style="text-align: center; width: 45%;">  4 Gas Sensors </div> <div style="text-align: center; width: 45%;">  5 Gas Bottles </div> <div style="text-align: center; width: 45%;">  6 Sensor Manifold Tube </div> </div>

PART #	STOCK	DESCRIPTION
1	APF3100	ORIGINAL RADEX FILTER CARTRIDGE
2	04-924	AUTO DRAIN UNIT
3	08-451	GX4 CALIBRATION FLOW REGULATOR FOR CO & ZERO AIR GAS BOTTLES (INCLUDES HOSE AND FITTING)
	08-452	GX4 CALIBRATION FLOW REGULATOR FOR H ₂ S GAS BOTTLES (INCLUDES HOSE AND FITTING)
4	08-420-01	GX4 GAS SENSOR CARTRIDGE CO 10 ppm
	08-420-02	GX4 GAS SENSOR CARTRIDGE CO 5 ppm
	08-420-03	GX4 GAS SENSOR CARTRIDGE H ₂ S 10 ppm
	08-420-04	GX4 GAS SENSOR CARTRIDGE OXYGEN 19.5-23 %
5	08-460	GX4 ZERO AIR (HAZMAT) FOR ZERO AIR AND OXYGEN SENSORS
	08-462	GX4 ZERO AIR (HAZMAT) FOR USE WITH H ₂ S 20 ppm CARTRIDGES
	08-461	GX4 CO 20 ppm (HAZMAT) FOR USE WITH BOTH 10 ppm AND 5 ppm CARTRIDGES
6	08-422	SENSOR MANIFOLD TUBE
	*NV2028	25' BREATHING AIR SUPPLY HOSE C/W CONNECTORS
	*NV2029	50' BREATHING AIR SUPPLY HOSE C/W CONNECTORS
	*NV2027	100' BREATHING AIR SUPPLY HOSE C/W CONNECTORS

*Air lines can be joined together up to 300' max overall length

FOR COMPLETE PARTS LISTING, DOWNLOAD RPB'S FULL PRODUCT CATALOG

BLAST SUITS

IST BLAST SUITS

IST offers a range of superior quality blast suits designed to produce the ultimate protection for workers, while increasing the comfort and productivity.

Available in ultralight nylon or durable leather, these suits are designed with only rugged materials and a combination of wear-resistant fabrics and porous cotton to keep the blaster dry and protected at all time.

The combinations include fastening straps to each cuff and to the bottom of the leg. A pair of heavy-duty leather gloves completes the set.



Ultralight Nylon

Heavy-Duty Leather

RPB BLAST SUIT

The RPB Blast Suit is a lightweight suit that provides protection against abrasive rebound.

It is made from heavy duty nylon to provide protection to the front of your body and arms, with a breathable cotton back to help keep you cool.

Features :

- ✓ Triple stitching for durability
- ✓ Optional knee pads
- ✓ Available in 7 sizes: S, M, L, XL, XXL, XXXL, XXXXL
- ✓ Robust nylon zipper with protective cover
- ✓ Elasticated waist for a comfortable fit
- ✓ Elasticated wrists and adjustable ankle cuffs
- ✓ Interior pocket



Leather Gloves

ISTBLAST LIMITED WARRANTY

ISTblast warrants all equipment led in this manual which is manufactured by ISTblast and bearing its name, to be free from defects in material and workmanship on the date of sale by an authorized ISTblast distributor to the original purchaser for use. Notwithstanding any special, extended or limited warranty published by ISTblast will, for a period of TWELVE (12) months from the date of sale, repair or replace any part of the equipment determined by ISTblast to be defective. This warranty applies only when the equipment is installed, operated and maintained in accordance with ISTblast's written recommendations.

This warranty does not cover, and ISTblast shall not be liable for general wear and tear, or any malfunction, damage or wear caused by faulty installation, misapplication, abrasion, corrosion, inadequate or improper maintenance, negligence, accident, tampering, or substitution of non-ISTblast component parts. Nor shall ISTblast be liable for malfunction, damage or wear caused by the incompatibility with ISTblast equipment with structures, accessories, equipment or materials not supplied by ISTblast, or the improper design, manufacture, installation, operation or maintenance of structures, accessories, equipment or materials not supplied by ISTblast.

This warranty is conditioned upon the prepaid return of the equipment claimed to be defective to an authorized ISTblast distributor for verification of the claimed defect. If the claimed defect is verified, ISTblast will repair or replace free of charge any defective parts. The equipment will be returned to the original purchaser, transportation prepaid. If the inspection of the equipment does not disclose any defect in material or workmanship, repairs will be made at a reasonable charge, which charges may include the costs of parts, labor, and transportation.

THIS WARRANTY IS EXCLUSIVE, AND IS IN LIEU OF ANY OTHER WARRANTIES, EXPRESSED OR IMPLIED, INCLUDING BUT NOT LIMITED TO WARRANTY OF MERCHANTABILITY OR WARRANTY OF FITNESS FOR A PARTICULAR PURPOSE.

ISTblast's sole obligation and the buyer's sole remedy for any breach of warranty shall be as set forth above. The buyer agrees that no other remedy (including, but not limited to, incidental or consequential damages for lost profits, lost sales, injury to person or property, or any other incidental or consequential loss) shall be available. Any action for breach of warranty must be brought forward within one (1) year of the date of sale.

ISTblast MAKES NO WARRANTY, AND DISCLAIMS ALL IMPLIED WARRANTIES OF MERCHANTABILITY AND FITNESS FOR A PARTICULAR PURPOSE, IN CONNECTION WITH ACCESSORIES, EQUIPMENT, MATERIALS OR COMPONENTS SOLD BUT NOT MANUFACTURED BY ISTblast. These items sold, but not manufactured by ISTblast (such as electric motors, switches, hose, etc.), are subject to the warranty, if any, of their manufacturer. ISTblast will provide the purchaser with reasonable assistance in making any claim for breach of these warranties.

LIMITATION OF LIABILITY

In no event will ISTblast be liable for indirect, incidental, special or consequential damages resulting from ISTblast supplying equipment hereunder, or the furnishing, performance, or use of any products or other goods sold hereto, whether due to a breach of contract, breach of warranty, the negligence of ISTblast, or otherwise.

The following items are not covered under the ISTblast warranty policy:

- Parts or chassis replacement due to normal wears.
- Defective material or workmanship is not considered normal wear.

Report all accidents or "near misses" which involve ISTblast products to our service department :

1 877 629-8202



ABOUT THE COMPANY

WHO WE ARE

IST is a leading manufacturer of equipment for the surface treatment industry and the solvent recycling industry. Our extensive line of equipment includes batch units and automated machines designed to achieve the highest manufacturing standards.

MISSION

IST works tightly with their customers to transform industrial processes to improve their quality, productivity, and environmental footprint.

OUR SERVICES

- Custom Design & Fabrication
- Installation & Startup
- Preventative Maintenance Program
- Private Labels
- Testing Lab
- 24/7 Technical Support

INDUSTRIES WE SERVE

- Aerospace & Aviation
- Aluminium Smelters
- Automotive
- Construction & Civil Engineering
- Flexography (labelling) & Lithography
- Foundry & Forge
- General Manufacturing
- Military
- Power & Energy
- Rail & Mass Transit
- Shipyards
- Wood finishing

