



Standard MRS200



DCM200 for MRS500

HIGH EFFICIENCY DUST COLLECTOR – DCM200 FOR PNEUMATIC ABRASIVE BLAST ROOM

The DCM200 is a high efficiency motorized dust collector specially designed for our abrasive blast room pneumatic recovery systems MRS200 and MRS500. Its exhaust system is equipped with a powerful turbine engine of 10 hp and over and provides high filtration efficiency to suck and extract fine particles and dusts from abrasive residues used during sandblasting operations.

This dust collector is designed for heavy-duty usage and is very efficient in preventing dust from escaping into the work environment, contaminating work surfaces and machines. Its frame is reinforced in order to resist a very high air suction demand. An optional horizontal muffler is available to reduce noise produced by the engine.

This heavy-duty motorized dust collector is equipped with a manual shaker (or optional automatic) allowing to dislodge the dust agglomerated on the surface of the filter bags. Extremely sturdy and durable, it requires minimal supervision and maintenance from the operator.

MARKETS

- General manufacturing
- Aerospace and aviation
- Marine
- Automotive
- Petroleum
- Power & energy
- Pharmaceutical

FEATURES

- ✓ Dust collector features an energy-saving air-filtration system captures 99,5 % of all particles three (3) microns or larger
- ✓ Reinforced frame designed to resist a very high air suction demand
- ✓ High efficient head motor exhausting system
- ✓ Barrel dust outlet with trap door
- ✓ Ease of access to the filter bags
- ✓ Replacement bags readily available
- ✓ QPS approved in Canada and the U.S.

No other dust collector on the market today offers the many practical benefits included on a ISTblast dust collector as standard equipment. Just look at the features. The standard components in a ISTblast system have been carefully designed for safety, ease of operation, reduced maintenance and increased productivity.

HOW IT WORKS

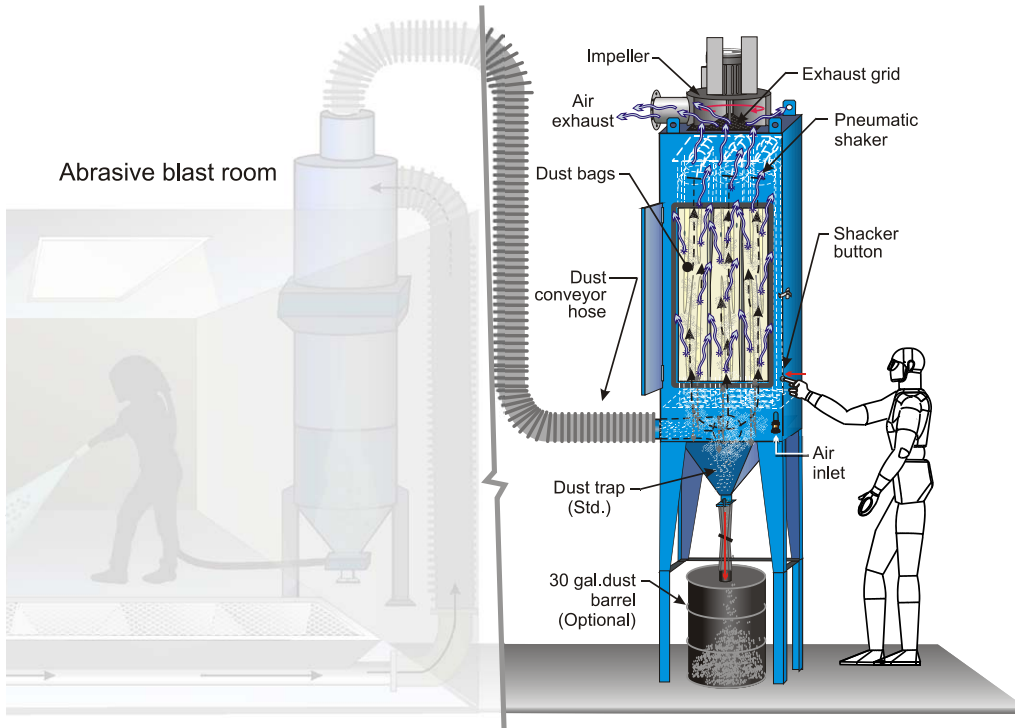

FLOOR LAYOUT

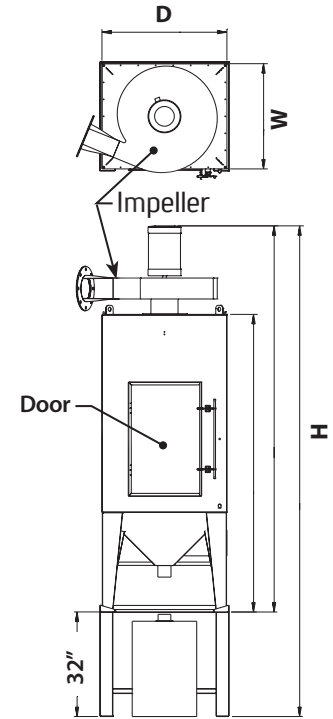

SOME OPTIONS



Impeller extraction system
10 hp / 800 cfm for MRS200

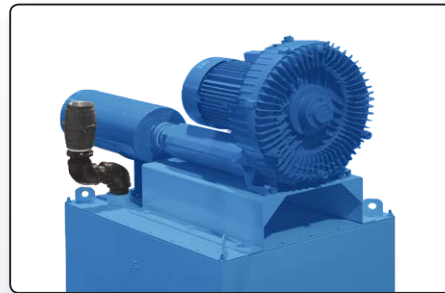

Impeller extraction system
20 hp / 400 cfm for MRS500

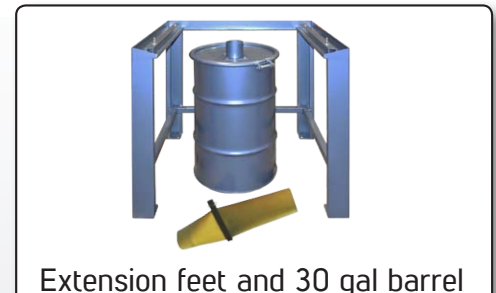

Extension feet and 30 gal barrel



Horizontal muffler

SPECIFICATIONS

Description	MRS 200	MRS 500
Model number	925029	925059
Filter Area (square feet)	200	
Fan motor (hp/cfm)	10/800	20/400
Suction power (inH2O)	40	110
Weight (lb)	525	575
Overall dim's (DxW)	34" x 40"	
Overall height without barrel (H)	118"	
Overall height with barrel (H)	150"	
Door opening (WxH)	20" x 32 1/2"	

RECOMMENDED SPARE PARTS



DB6 bag (30)
601316

Piston
608405