



## AGITATION TANK PARTS WASHERS

ISTpure Agitation Tank Parts Washers are designed to clean parts using adjustable agitation platform that can produce up-to 100 agitations per minute. Agitation parts washers are very effective for cleaning and flushing out internal dimensions and cavities of various parts alone or in a batch process.

Simply load parts in a basket from top opening or set larger parts on the platform, set wash cycle length and agitation speed, then let the agitation lift do the work! Parts are immersed in cleaning fluid as the agitation platform oscillates vertically to dislodge grease and oil on surface and in cavities without hurting parts surface.

For use with aqueous-based cleaners or petroleum solvents with flash point over 107° F. Do not use with chlorinated solvents.

### AW SERIES AQUEOUS-BASED VERSION

The AW Series Aqueous system is built with 12-gauge stainless steel construction. It features 6,000 watt heating elements with thermostat preset and backup thermostat (non-adjustable) that can heat cleaning fluid up to 110°F (43°C) for better cleaning action. The thermostat can run plus or minus 4 °F.



*For use with aqueous-based*

### AL SERIES SOLVENT VERSION

The AL Series Solvent system is built with heavy-duty steel construction coated with baked epoxy-powder finish. An optional stainless steel construction and finish is available for long-lasting durability.



*For use with mineral spirits based solvents with a flash point greater than 40° C (104° F).*

### FEATURES

- ✓ **Tank Capacity:** 80 or 150 gallons
- ✓ **Agitation System:** Self-cleaning agitating platform with top opening and spring-loaded door closures for easy loading/unloading
- ✓ **Adjustable Agitation Speed:** agitations range from 0 to 100 agitations per minute
- ✓ **Pneumatic System:** Operates on 120 psi air pressure
- ✓ **Inner chamber** is made of heavy-duty stainless steel components
- ✓ **Supplied Accessory:** Flow-through hand-held brush
- ✓ **Standard Pump:** Electric fractional horsepower motors
- ✓ **Preset 120 psi filter regulator** with auto drain



## OPTIONAL FEATURES

- ✓ **Filtration System:** Recirculation filtration system with filter elements that can be added to keep cleaning fluid free of solid contaminants
- ✓ **Optional Pump:** Air Pump

## FLOOR PLAN

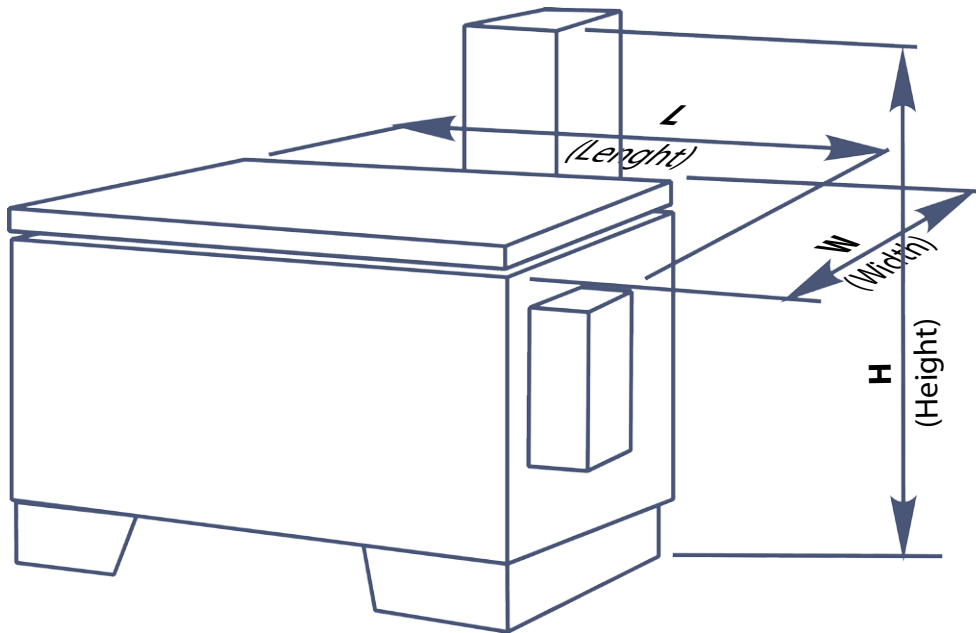

## SPECIFICATIONS

Features	Agitation Tank 80	Agitation Tank 150
Fluid capacity	80 gallons	150 gallons
Fluid level	12"	17 1/2"
Load Capacity	250 lb	750 lb
Overall Dimensions (W x L x H)	33" x 51 1/2" x 66 1/2"	44 1/2" x 64" x 69"
Inside Dimensions (w x l x h)	27 1/4" x 44 1/2" x 28"	37 1/2" x 57" x 30"
Carrier Dimensions (w x l)	17 1/2" x 41 1/2"	27 3/4" X 54"
Shipping Dimensions (ws x ls x hs)	36 1/4" x 56 1/2" x 56 1/2"	48" x 68 1/2" x 57 1/4"
Shipping Weight	556 lb	750 lb
Air Requirements	8 cfm @ 120 psi	25 cfm @ 120 psi
Electricity Requirements	115 V / 1 A / 60 Hz	

