



SANDBLASTING BOOTH MECHANICAL RECOVERY SYSTEM WITH SCREW CONVEYOR AND BUCKET ELEVATOR



TABLE OF CONTENTS

	Page
INTRODUCTION	2 to 4
SYSTEM OVERVIEW	5
ABRASIVE MEDIA RECOVERY SYSTEM	6 to 12
PRESSURE VESSEL.....	13 to 16
OPERATION	17
WARNINGS FOR PRESSURE VESSELS.....	18
SAFETY , INSTALLATION AND SERVICE INSTRUCTIONS FOR SCREW CONVEYORS	19
PRESSURE VESSEL - HOW IT WORKS	20,21
HMI	22
SCHNEIDER HMI* CONTROL PANEL	23 to 28
FATEK HMI* CONTROL PANEL.....	29 to 36
MAINTENANCE	37
BOOTH ENCLOSURE	38 to 41
BUCKET ELEVATOR.....	42
DUST COLLECTOR	43
DCT1000 CONTROLLER PERIODICAL ADJUSTMENTS	44, 46
ABRASIVE METERING VALVE PMV-186 - ASSEMBLY / DISASSEMBLY PROCEDURES	47, 48
ABRASIVE METERING VALVE AR-7 + A6 - ASSEMBLY / DISASSEMBLY PROCEDURES	49, 50
ABRASIVE METERING VALVE AV-186 - ASSEMBLY / DISASSEMBLY PROCEDURES	51
PRESSURE VESSELS - PREVENTIVE MAINTENANCE SCHEDULE	52
REMOTE CONTROL HANDLES - ASSEMBLY / DISASSEMBLY PROCEDURES	53
FITTINGS, HOSES & NOZZLES, SELCTION GUIDE	54, 55
SAFETY EQUIPMENT	56
AIR BREATHING - PROTECTIVE EQUIPMENT FOR THE OPERATOR	57 to 61
BLAST SUITS	62
ISTBLAST LIMITED WARRANTY	63
ABOUT THE COMPANY	64

INTRODUCTION

Welcome to the ISTblast family of sandblasting products. This booklet contains helpful information and acquaints you with the operation and maintenance of your equipment. Please read carefully and follow our recommendations to assure trouble free operation. If you have any questions, please do not hesitate to contact your distributor or our technical service.

The products described in this manual, and the information relating to those products, is intended for knowledgeable, experienced users of abrasive blasting equipment.

No representation is intended or made as to the suitability of the products described herein for any particular purpose or application. No representations are intended or made as to the efficiency, production rate, or the useful life of the products described herein. Any estimate regarding production rates or production finishes are the responsibility of the user and must be derived solely from the user's experience and expertise, and must not be based on information in this manual.

The products described in this manual may be combined by the user in a variety of ways for purposes determined solely by the user. No representations are intended or made as to the suitability or engineering balance of the combination of products determined by the user in his selection, nor as to the compliance with regulations or standard practice of such combinations of components or products.

It is the responsibility of the knowledgeable, experienced users of the products mentioned in this manual to familiarize themselves with the appropriate laws, regulations and safe practices that apply to these products, equipment that is connected to these products and materials that may be used with these products.

It is the responsibility of the user to insure that proper training of operators has been performed and a safe work environment is provided.

Our company is proud to provide a variety of products to the abrasive blasting industry, and we have confidence that the professionals in our industry will utilize their knowledge and expertise in the safe efficient use of these products.

DEFINITION OF TERMS USED IN THIS MANUAL

Abrasive (also known as “media”): granular material used for blasting a surface.

Blow down (also known as “depressurize”): to expulse air automatically or manually from a pressurized vessel.

Control Handle: mandatory remote-control device used to start and stop the blaster.

Depressurize (also known as “blow down”): to expulse air automatically or manually from a pressurized vessel.

Pressure Hold System (also known as “manual blow-down system”): blasting system in which the pressure vessel stays pressurized when the control handle is released.

Pressure Release System (also known as “automatic blow-down system”): blasting system in which the pressure vessel is automatically depressurized when the control handle is released.

Pressure Vessel: enclosed section of the blaster filled with pressurized air and abrasive during blasting operations.

Pressurize: to fill the pressure vessel with compressed air.

Properly Trained Person: a person who has successfully passed a training course in sandblasting pertaining mainly to the safe operation of stationary or portable Abrasive Blasters with capacities ranging from 1.5 ft³ to 6.5 ft³ and who has read this entire manual and understands it

Silica : hazardous substance found in many naturally occurring abrasives. Dust produced by blasting with abrasives containing silica can cause respiratory diseases.

NOTE: Abrasives containing silica must NEVER be used in any blasting situation. Even if respiratory protective equipment is used, the resulting dust can cause respiratory disease

SAFETY SYMBOLS

The safety symbols below are designed to ensure the safety and protection of the Abrasive Blaster operator and of anyone else nearby. The explanations provided apply to sandblasting equipment.



OR



WARNING : This symbol indicates a potentially dangerous situation that could result in serious injury or death if the instructions related to the symbol are not carried out. Throughout the manual, this warning triangle will appear to denote instructions requiring special attention.



OR



DANGER : This symbol indicates a potentially dangerous situation that WILL result in serious injury or death if the instructions related to the symbol are not carried out. Throughout the manual, this warning triangle will appear to denote instructions requiring special attention.



SYSTEM OVERVIEW

ABRASIVE BLAST ROOM STRUCTURE - AIR CIRCULATION

The suction fan, through the dust collector and conduit network, creates a negative pressure of 1/2 "w.g. (Nominal) at one end of the blowing room. This causes the outside air to be sucked through the air inlets at the opposite end of the chamber and the development of a cross-flow airflow. The exhaust outlet is diverted to allow only the transport of dust-laden air. The inputs and outputs are proportionally sized to ensure adequate volume and airflows.



INPUT DEFLECTORS

Room air inlet

The dimensions and quantity of deflectors depend on the size of the abrasive blast room (they can also be on the doors)



OUTLET DEFLECTORS

Abrasive Sandblast Booth air outlets

Go to the dust collector of the abrasive blast room. The dimensions and the quantity of deflectors depend on the size of the abrasive blast room

ABRASIVE AND CLEANING SYSTEMS - CONFIGURATIONS

The steel grids cover the screw conveyors. These conveyors carry the media to a rotating screen basket that separates the media from the larger debris. The media coming out of the rotary basket feeds a vertical bucket elevator. Once raised, the media falls into an air wash system. This air washing system extracts dust from the media drop which continues its way to the storage hopper. The storage hopper feeds the media into the pressure vessel as used by the operator and so on.

RECOVERY AREA

Many configurations are available, see your custom drawing provided by ISTblast to meet your needs.

SOME EXAMPLES OF CONFIGURATIONS:

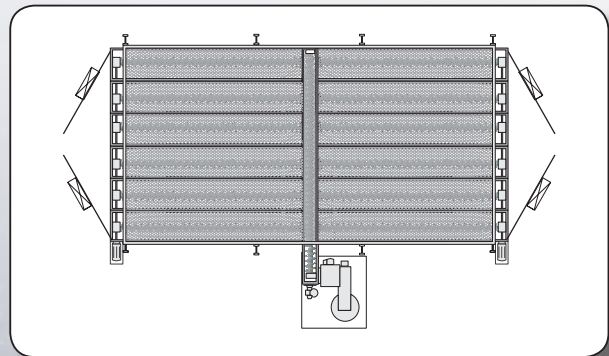
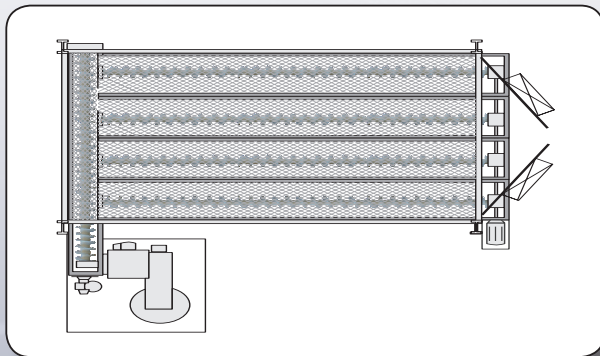
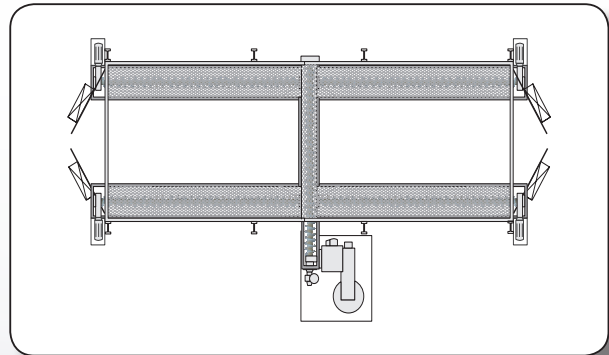
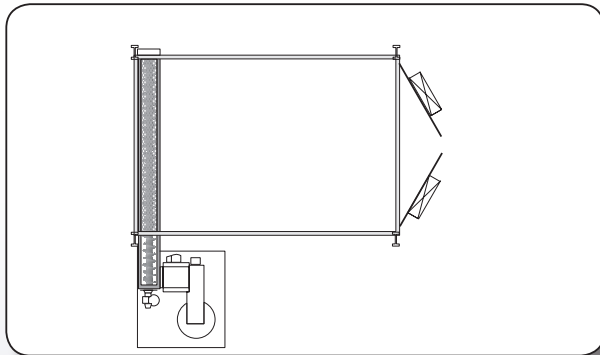
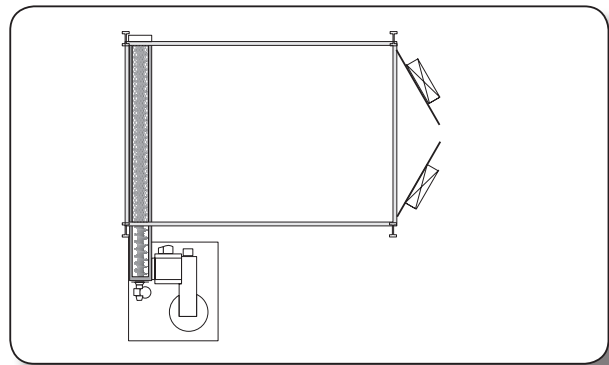
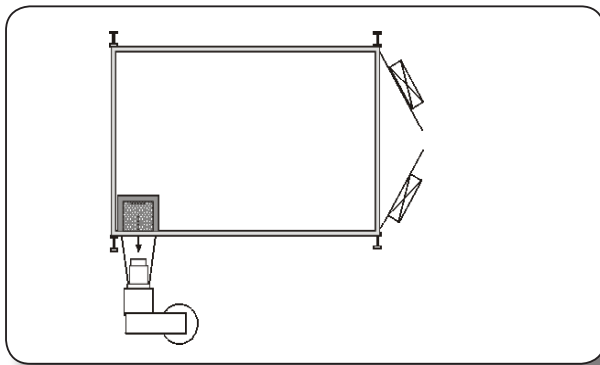

ABRASIVE AND CLEANING SYSTEMS - SCREW CONVEYOR

LONGITUDINAL

The longitudinal conveyor modules on the floor consist of a 10 ga steel screw structure. The screw is supported by a suspension bearing..

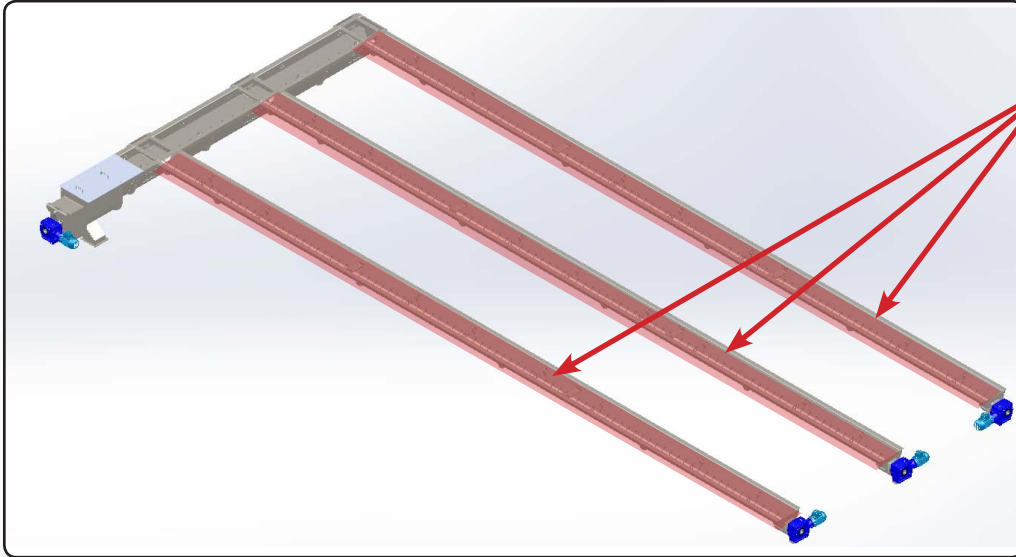

The dimensions and the number of units depend on the chosen configuration.

CROSSING

The transverse screw conveyor modules on the floor consist of a 10 ga steel screw structure. The screw is supported by hanger bearings. The transverse screw conveyor collects the overflow from the longitudinal screw conveyor.

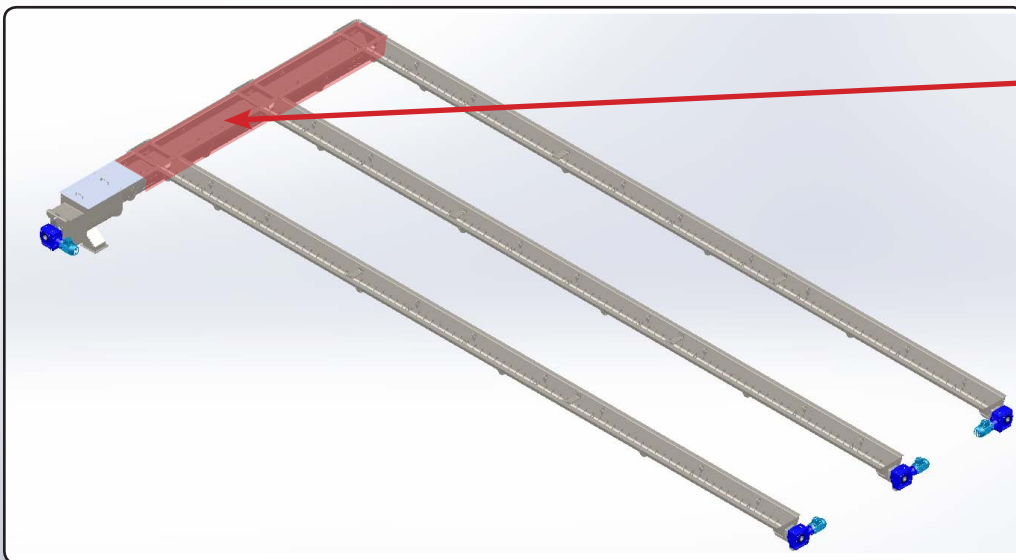

The dimensions and the number of units depend on the chosen configuration.

ABRASIVE MEDIA RECOVERY SYSTEM - OVERVIEW

Worn media are collected by the screw conveyor system incorporated into the floor and conveyed to the bucket elevator. Up the bucket elevator, the dirty media mix travels through a perforated screen drum, where particles with higher density are diverted into a rejection drum, to reach the air wash media separator. The air wash separates media based on its density and return only media still in good working condition back to the storage hopper.

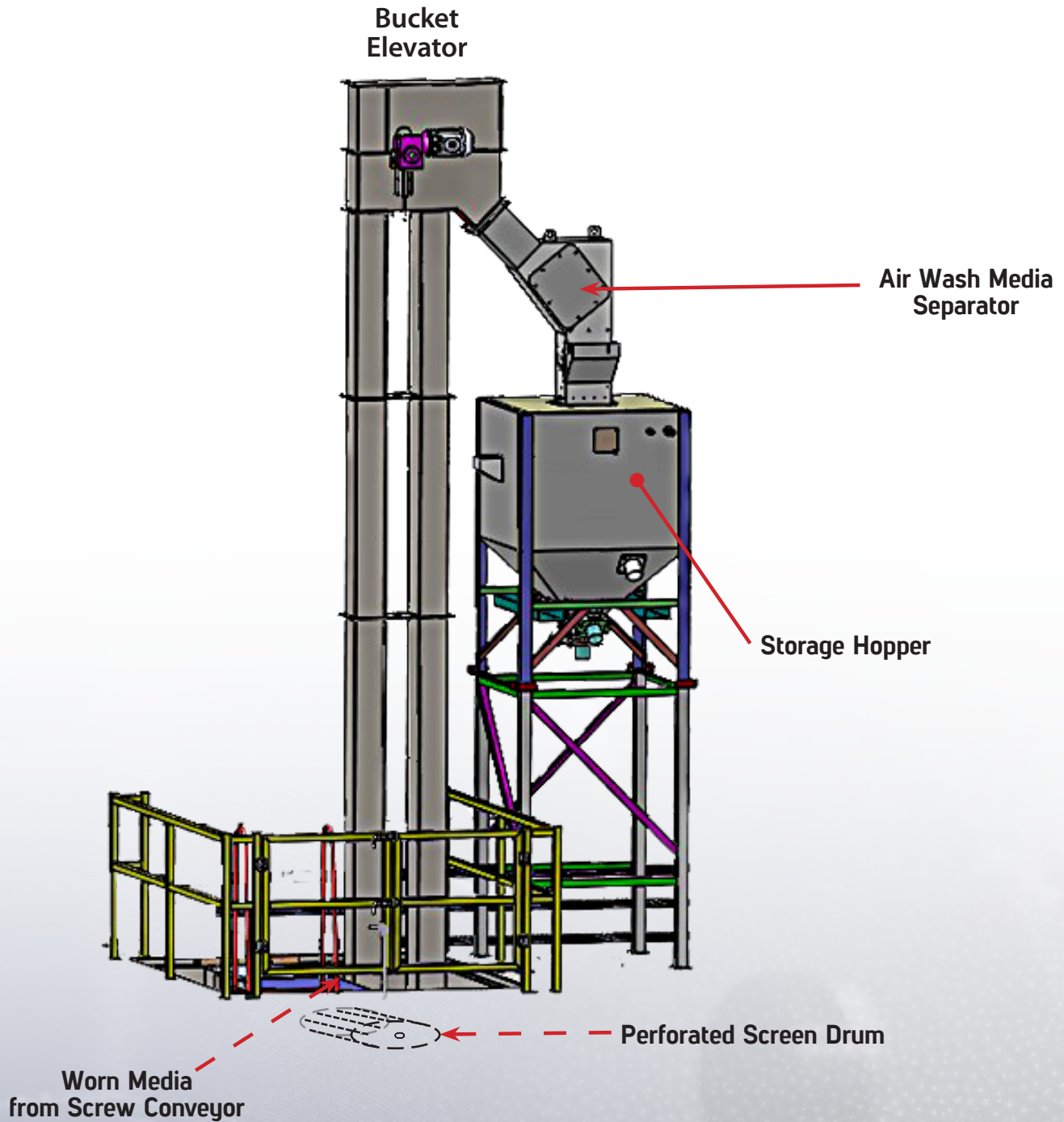

ABRASIVE AND CLEANING SYSTEMS - PERFORATED ROTARY DRUM

A rotating screen drum is installed at the end of the transverse screw conveyor to filter out larger debris that could have contaminated the media. The rotating drum screen consists of a 11 gauge steel sheet with 3/16" diameter holes. The body of the rotating basket is 30" long by 14" diameter. There is a welded helix inside and outside the body.

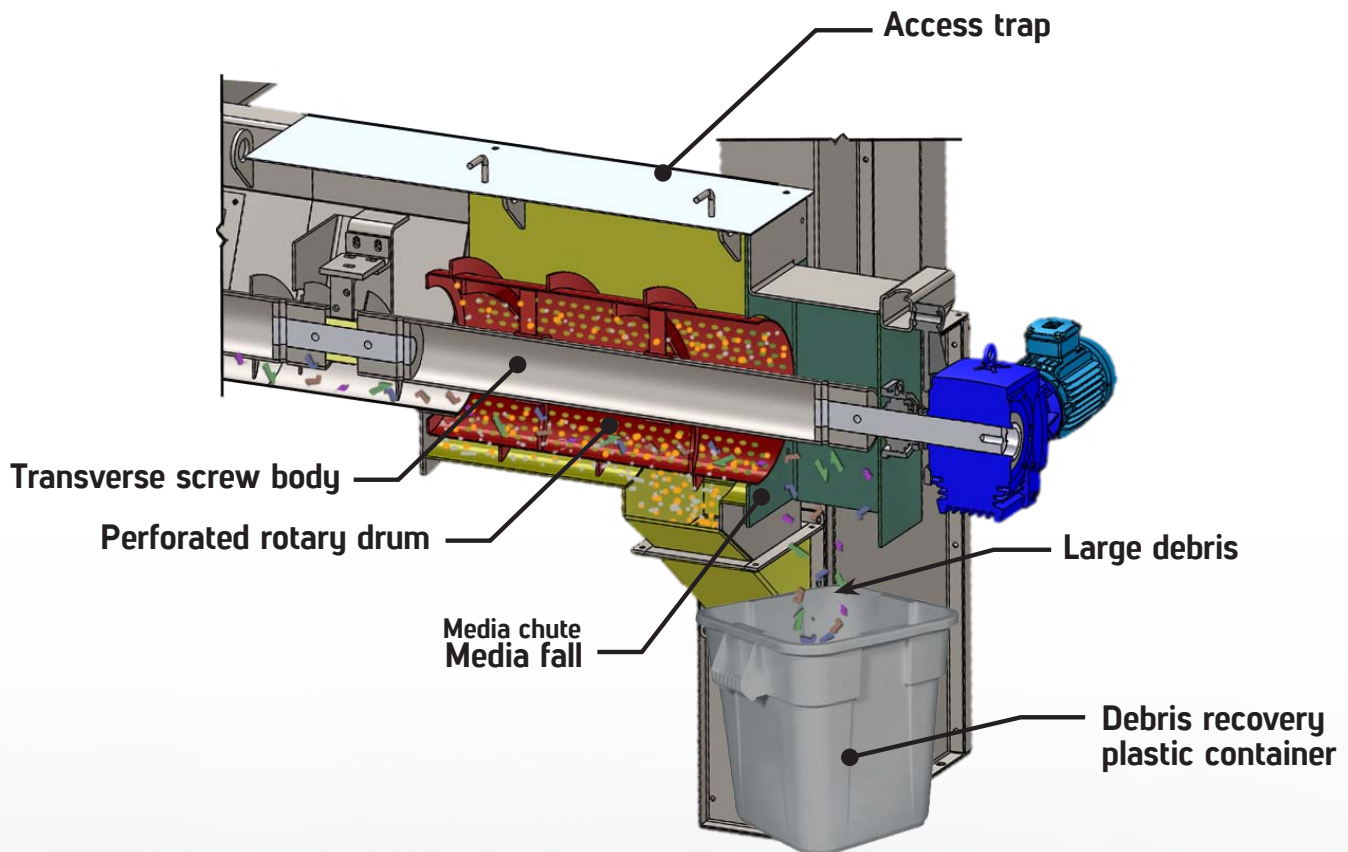

LEGEND	
	Media
	Dust
	Debris

ABRASIVE RECOVERY SYSTEMS - AIR SEPARATION SYSTEM

Reusable media, dust and non-reusable media from the bucket elevator fall into the air separation system consisting of several deflectors. A flow of air is created by the fall of the support allowing to extract the dust from the mixture. The reusable media is directed to the storage hopper to fill the sandblasting pot. A selection of granularity is made possible by an internal door. The non-reusable media is lighter than the reusable media but heavier than the dust, so it can be directed into the non-reusable drop which is ultimately connected to a recovery barrel.

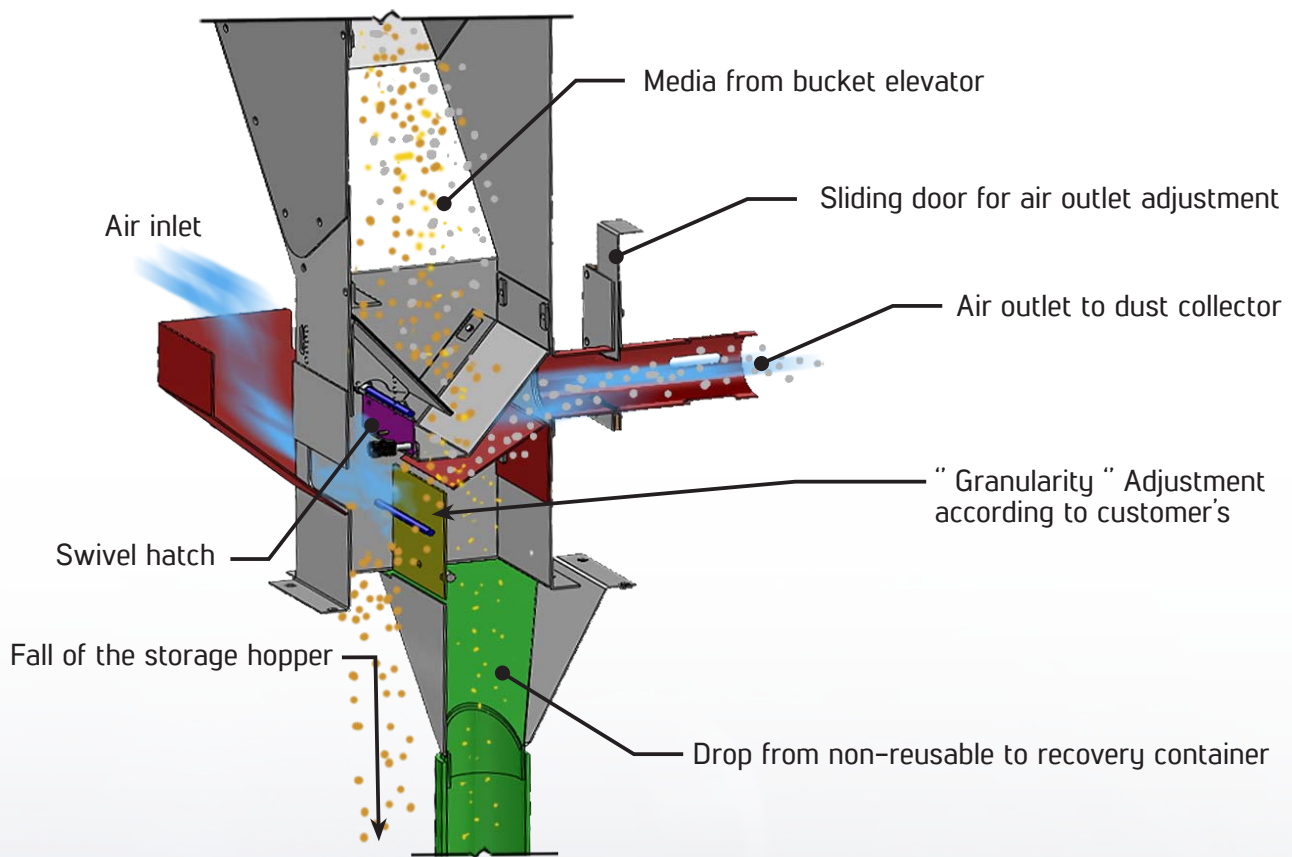

LEGEND	
	Air
	Reusable media
	Non-reusable media
	Dust

ABRASIVE MEDIA RECOVERY SYSTEM - AIR SEPARATION SYSTEM (CONT'D)

The adjustment of the air separator to fine-tune the selection of the granularity is made possible by the external lever located on the side of the assembly.

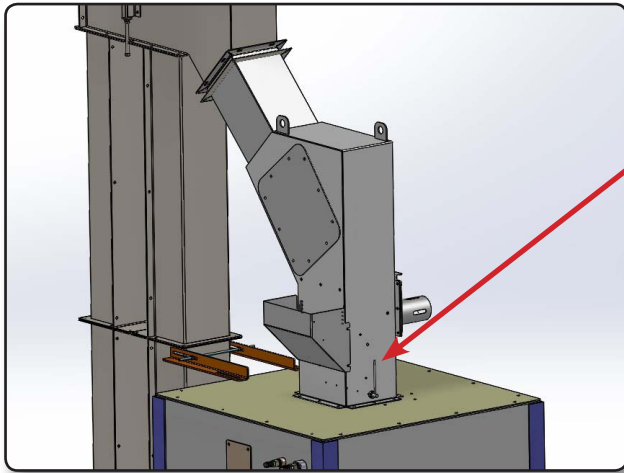

Adjustment deflector to increase or decrease the airflow speed

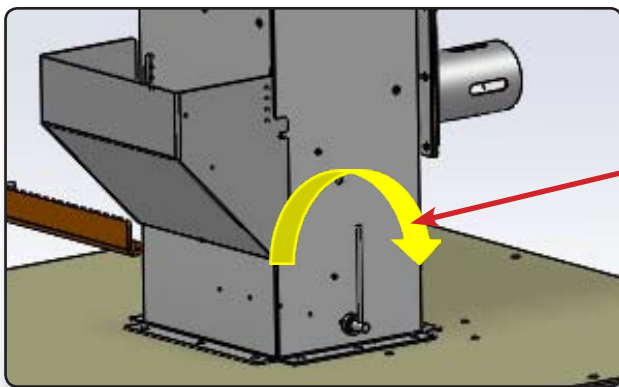

A wider range of media granularity will fall into the storage hopper.

The media mixture will include fine particles

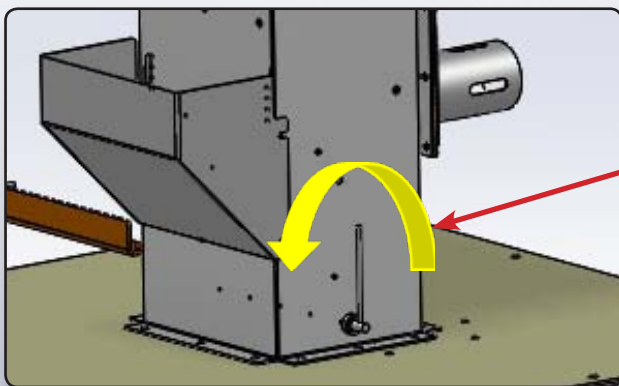

A smaller range of media granularity will fall into the storage hopper.

The reused media will have fewer fine particles

CONTROL BOX

REMOTE "BLAST ON/AIR ONLY" SWITCH

A pneumatic cut-off switch is provided to turn your blast hose into a powerful air blower producing high velocity compressed air to blow dust off of the workpiece and to clean the floor by blowing abrasive media remains towards the nearest floor recovery hopper. This switch controls the opening and closing of the abrasive metering valve on the remote control handle.

When sandblasting is completed, the operator simply places the switch in the "AIR ONLY" position, stopping the flow of abrasive. The air valve remains open so that only high-speed compressed air flows from the nozzle.



PRESSURIZED/DEPRESSURIZED VESSEL SWITCH

The depressurization switch located inside the blast booth allows the operator to fill up its pressure pot without the hassle of leaving the booth and taking off the safety equipment.

This switch controls the AV-176 Combo Air Valve to release the pressure inside the blast pot, allowing the plunger to fall and let the blast media contained into the recovery hopper to fill up the pot.

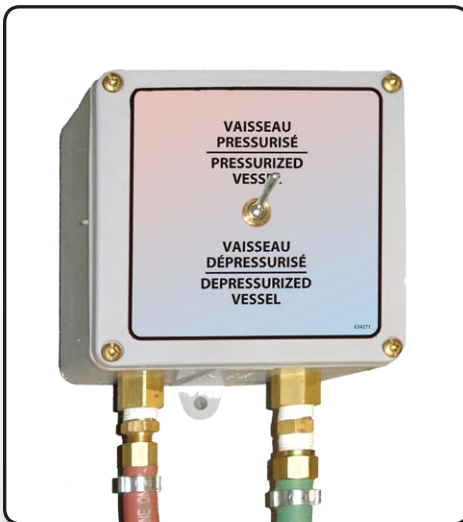

PRESSURE VESSEL - CONTROL VALVES

ABRASIVE METERING VALVES



AR7+A6 MEDIA METERING VALVE ASS'Y

The AR7 abrasive metering valve can control the flow of abrasive that falls into the blast stream by the use of a crank. The pneumatic actuating function is controlled by the A6 actuator separately. Usually close, the A6 actuator opens the orifice and let the blast media flow through when the blast flow is activated by the operator.

OR



PMV-186 MEDIA METERING VALVE

This valve is designed in such a way that the manually adjustable measuring function and the pneumatic actuating function of the valve are carried out separately, enabling rapid and inexpensive replacement of the worn parts.

AIR VALVES



AV-176 COMBO VALVE

The AV-176 valve is a one-piece combination inlet and outlet valve utilized to control compressed air supply into and out of the blast pot.

A single piston assembly is utilized to both open and close the valve's inlet and outlet sections.



AV-186 AIR VALVE

The AV-186 is a diaphragm air valve that controls the air flow of the jet stream when the vessel is pressurized. By default, this valve is closed. When the operator activates the remote control handle, the AV-186 Air Valve opens and let the compressed air flow through the jet stream, where it mixes up with the media and then propels it at high velocity on the workpiece.

FOR PARTS DETAILS VALVES, SEE SANDBLASTING PRESSURE POT INSTRUCTION MANUAL.

PRESSURE VESSEL - ABRASIVE BLAST LINE



SANDBLAST HOSE

The sandblast hose, which transmits compressed air and media to the blast nozzle, has an internal diameter of 1¼" and an outside diameter of 2 5/32". It weighs 60 pounds for each 50' length. The hose is rated for a working pressure of 175 psig. The hose fitting is ¼" thick, rubber impregnated with carbon black for static dissipation. It is equipped with quick and light aluminum couplings that mount outside and incorporate self-locking safety wires. Fifty (50) feet of sandblast hose and control lines are supplied with each blasting machine. An optional 12 ½" "whip" hose is available at the last section to provide the user with more flexibility and less weight to carry on his back.



SANDBLAST NOZZLE

A 3/8" I.D. double venturi nozzle will be supplied with the sandblasting machine. The nozzles are made of the highest quality materials and designed for a long service life. The nozzle is connected to the sandblast hose with an externally mounted nylon nozzle holder.



OPERATOR REMOTE CONTROLS

The remote controls are pneumatic type, and include a normally closed inlet valve and a normally open outlet valve. The air pressure opens the inlet valve and closes the outlet valve to begin the sanding process. In the event of loss of air pressure on the valves, the springs return the valves to their normal position.

If your sandblast hose is 75 feet or more the remote control should be electric.

ABOUT THE REMOTE CONTROL SYSTEMS

An electric or pneumatic remote control system (also called "Deadman") must always be used with a sandblasting pot to start and stop blasting.

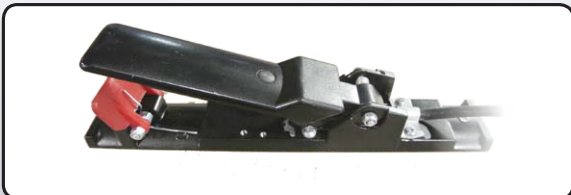

Electrical: On the sandblasting pot, the remote control handle must be connected to the female socket with rotating latch of the blasting pot. A 12 V DC power source (12 V battery or optional 120 V AC to 12 V DC converter) must be connected to the male latch connector.



Pneumatic: The dual remote control hose must be connected to the blasting pot using supplied threaded or quick disconnect couplings. The use of pneumatic remote control systems is not recommended with sandblast hoses over 100 feet.

PRESSURE VESSEL AIR CONSUMPTION - PRESSURE SYSTEM

		SUITABLE AIR JET / NOZZLE COMBINATIONS - PRESSURES (psi) ²													
Nozzle I.D. ⁴	Units	20	25	30	35	40	45	50	60	70	80	90	100 ⁰	120	
1/8"	cfm ¹	7	7	8	9	10	12	13	14	15	17	19	20	25	
	lb/h ³	48	48	55	62	69	72	77	82	110	127	140	154	192	
3/16"	cfm ¹	15	16	18	20	22	24	26	30	33	38	41	45	55	
	lb/h ³	94	101	114	127	140	153	166	192	220	243	268	297	363	
1/4"	cfm ¹	27	30	34	37	41	45	49	55	61	68	74	81	97	
	lb/h ³	174	193	219	251	276	303	329	369	398	460	504	556	666	
5/16"	cfm ¹	42	46	53	57	65	70	76	88	101	113	126	137	152	
	lb/h ³	254	278	320	345	394	425	462	528	680	756	832	910	1010	
3/8"	cfm ¹	55	63	76	82	91	100	109	126	143	161	173	196	220	
	lb/h ³	374	428	517	558	620	682	744	860	970	1080	1184	1296	1454	
7/16"	cfm ¹	72	85	100	112	124	137	149	170	194	217	240	254	300	
	lb/h ³	488	576	678	759	835	840	908	1160	1320	1476	1630	1782	2104	
1/2"	cfm ¹	96	112	129	146	165	179	195	224	252	280	309	338	392	
	lb/h ³	629	734	845	976	1103	1197	1305	1500	1700	1890	2088	2277	2640	
5/8"	cfm ¹	173	195	212	239	260	282	308	356	404	452	504	548	611	
	lb/h ³	1081	1219	1325	1470	1600	1716	1875	2140	2422	2690	2973	3250	3623	

LEGEND

- ⁰ Optimal pressure
- ¹ cfm: compressed air required in cubic feet minute
- ² psi: pounds per square inch
- ³ lb/h: abrasive consumption in pounds per hour
- ⁴ Nozzle I.D.: nozzle interior diameter

OPERATION



WARNINGS FOR PRESSURE VESSELS

WARNING

- All persons who will be operating or will be in the vicinity of the Abrasive Blaster during its operation must receive proper training on how to safely operate the equipment and be informed of the potential hazards involved. In addition to proper training, all persons who will be operating or will be in the vicinity of the Abrasive Blaster during its operation must read, understand and follow all procedures described in the user's manual. For replacement manuals, please contact your distributor or visit www.ISTblast.com.
- Respiratory protection is mandatory for all persons operating or located in the vicinity of the Abrasive Blaster. Follow all OSHA and NIOSH requirements for breathing equipment and supplied air standards.
- Pressurized Vessels contain large amounts of stored energy and can cause severe injury or death if safety procedures are not followed. Never perform maintenance or attempt to open a Pressure Vessel for any reason while it is Pressurized. Always Depressurize and properly disconnect equipment from its air source before performing any maintenance. Do not modify, grind or weld on the pressure vessel for any reason. Doing so will void the ASME certification. Do not use damaged pressure vessels.
- The use of proper remote control systems (commonly referred to as Deadman controls) are required when using abrasive blasters. Never operate the Abrasive Blaster without remote controls. Never use bleeder type control handles, with RC175 or RC185 series blasters as they can cause a hazardous situation where the blaster will not shut off when the handle is released.
- All persons who will be operating or will be in the vicinity of the Abrasive Blaster during its operation must protect themselves with the proper safety equipment and use of common sense. Safety equipment including but not limited to Hearing, Eye, Body and Lung protection are required. Abrasive blasters and the objects being blasted can be heavy and can lead to severe injury or death if they fall over. Always follow all safety requirements of OSHA and NIOSH.
- Use only Genuine ISTblast replacement parts when performing maintenance on the Abrasive Blaster. Do not modify the equipment for any reason. Use of modified brand parts can cause an unsafe situation and will void your warranty.
- Never use malfunctioning or damaged equipment. Before each use, inspect the Abrasive Blaster for proper function.
- Supply only cool, dry, compressed air that is free of debris to the Abrasive Blaster. Moisture or debris that reaches the remote control system can cause an unsafe situation. Do not supply compressed air to the blaster that exceeds 150 psi.
- Use of an air line pressure regulator is strongly recommended.
- Do not use abrasive blasters in areas that could be considered a hazardous location as described in the National Electric Code NFPA 70, Article 500. Never use the Abrasive Blaster in wet environments. Always connect electrically controlled abrasive blasters to a Ground Fault Circuit Interrupter (GFCI).

PRESSURE VESSEL - HOW IT WORKS

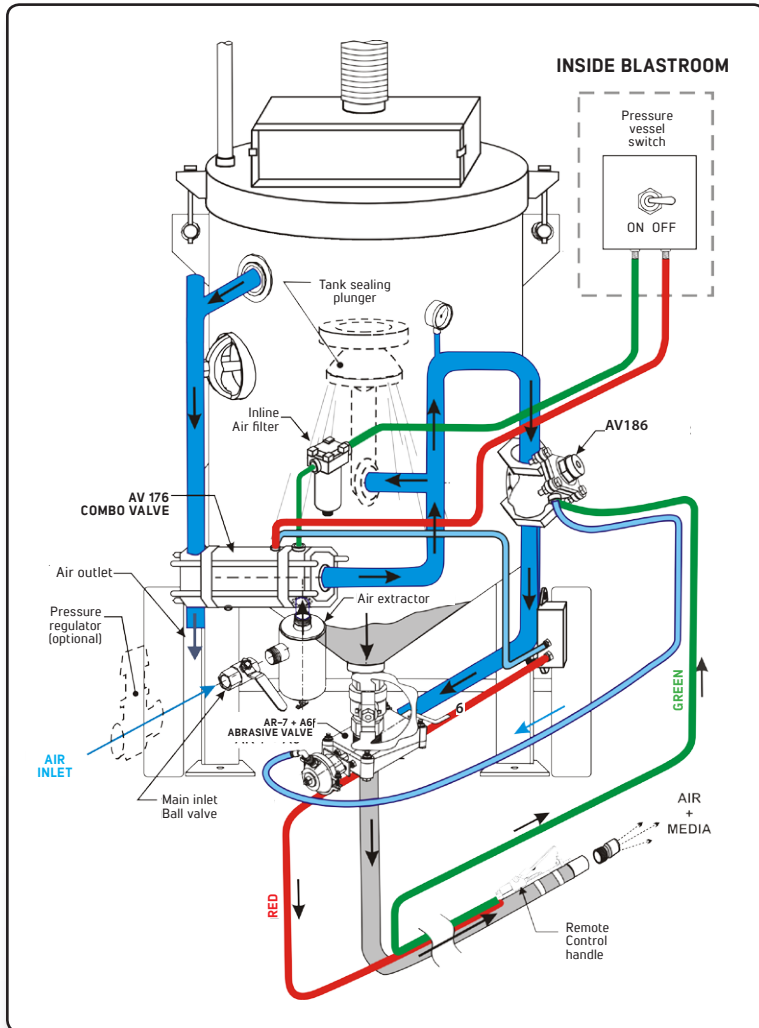

- The customer supplies the air supply to a normally closed AV-176 valve.
- When the PRESSURIZATION SWITCH is activated, the AV-176 combined air valve opens to allow air to enter and pressurize the tank. The pressure tank is now ready for the sandblasting operation
- In order to start the sandblasting operation, all the doors of the sandblasting room, equipped with a safety switch, must be closed.
- It is only when all the doors are closed that the operator will be able to start the blasting operation.
- The operator will start the operation by pressing the control handle located on the sanding hose near the nozzle.
- The AV-186 air valve and AR-7 abrasive metering valve then open to begin the sanding operation.
- When the operator releases the control handle, the sanding operation stops. The pressure vessel remains under pressure, ready to repeat the sanding operation when the operator presses the control handle again.
- When the blasting operation is complete or when the pressure vessel is to be filled with the abrasive, the operator releases the control handle. In order to depressurize the tank, the operator must turn the depressurization switch to the OFF position.



WARNING

CAUTION: NEVER LEAVE THE PRESSURE VESSEL UNDER PRESSURE WHEN NOT USED.

The pressure vessel must be depressurized and the air supply deactivated.

SETTING UP THE BLASTER

WARNING

The Procedures provided in the Operating Procedures section of the manual are designed to provide basic information on how to safely operate the features of ISTblast RC-176 / RC-186 Series Abrasive Blasters. Only personnel thoroughly trained in abrasive blasting should operate the Abrasive Blaster.

INSPECT PRESSURE VESSEL

When you receive your Abrasive Blaster, remove the Handway Assembly and check for foreign items that may have fallen into the Abrasive Blaster through the Pop-up opening. Remove any foreign materials and reinstall the Handway Assembly.



DANGER : Never perform any maintenance or attempt to open the Abrasive Blaster in any way while it is pressurized. The violent release of compressed air and propelled objects will cause serious injury or death.

RE-TIGHTEN HANDWAY ASSEMBLY

After the Abrasive Blaster has been pressurized for the first time, tighten the nut on the Handway Assembly. Tightening the nut on the Handway Assembly should also be done any time after the handway has been removed for maintenance before and after the next pressurization.



DANGER : Never perform any maintenance or attempt to open the Abrasive Blaster in any way while it is pressurized. The violent release of compressed air and propelled objects will cause serious injury or death.

PURGE AIR SUPPLY HOSE

Before connecting the Air Supply Hose to the Abrasive Blaster, purge the hose of any moisture or foreign debris. Standing water or moisture in the air line will cause degraded performance of the Abrasive Blaster. Air supplied to the Abrasive Blaster must be clean, dry and cool.

ATTACH REMOTE CONTROL HANDLE

Attach the Remote Control Handle to the Blast Hose near the Nozzle with hose clamps or heavy wire ties.

Form a loop of Twinline/Control Cord that comes 6" away from the Blast Hose, runs 6" parallel to the Blast Hose, and comes 6" back to the Blast Hose. Using duct tape, attach the Twinline/ Control Cord to the Blast Hose where the loop ends by wrapping the tape around the Twinline/Control Cord twice and then around the Blast Hose.

At the point where the buckle ends, attach the Twinline / Control cord to the sandblasting hose by twice wrapping tape around the Twinline / control cord and then around the blast hose to form a decompression clip.

Do this only on the first connection near the control handle. Attach the remaining Twinline / Control cord to the blast hose by wrapping tape around the cord and hose every 3 feet, beginning at the end of the blast hose nozzle.

SAFETY, INSTALLATION AND SERVICE INSTRUCTIONS FOR SCREW CONVEYORS

WARNING

The important information contained in this manual must be reviewed and applied by the contractor, installer, owner and user.

Screw conveyors are not normally manufactured or designed to function in the handling of hazardous materials or in a hazardous environment. Contact ISTblast if there is a risk that a hazardous condition or material is involved.

Hazardous materials may be explosive, flammable, toxic or dangerous to personnel if they are not completely and completely contained in the conveyor housing. Special construction of conveyor housings with special bolted joints and lids and case design can sometimes be used for handling this type of material.

Screw conveyors are not manufactured or designed to comply with local, state or federal codes in non-standard pressure vessels. When a zone of product is under pressure or under vacuum, or the vessel is provided with heating or cooling walls, special precautions are necessary.

During the blasting operation, the worn media falls onto the floor of the blast chamber and through the steel mesh into the recovery and cleaning system. The media on the ground must be swept into the screw hopper in order to be recovered.

SECURITY

Most accidents involving property damage or injury are the result of negligence or lack of attention from someone. To avoid such accidents, one of the many things to do is to make machines that eliminate as far as possible an unsafe or dangerous condition. Screw conveyors shall be installed, maintained and used with the following minimum requirements:

- Screw conveyors should not be used as long as the outer structure of the conveyor does not completely protect the moving parts and all transmission guards are in place. The following warning signs (see CEMA Safety Labels SC-2 and 86-3) are attached to all conveyor housings in the specified locations. These labels should not be removed from the boxes or be painted over them! Replacement labels can be ordered from the Transport Equipment Manufacturers' Association (CEMA).
- Do not overload the conveyor or use it for any purpose other than intended use.
- Feed openings for shovels or other manual or mechanical equipment shall be so constructed that the rotating and moving parts of the conveyor are closed and restrict access to the conveyor.
- Always turn off power before servicing..
- ISTblast does not perform electrical design services and therefore does not provide electrical appliances, unless the purchaser has expressly stipulated.
- ISTblast will endeavor to assist, to the best of its ability, in selecting equipment or equipment that will assist the owner and installer in the preparation of a safe installation and a safe workplace. Zero speed switches and other electrical devices can detect the operation of the conveyor so that operations can be interrupted and / or alarms can be actuated.
- There are many types of electrical interconnection devices for conveyors, elevators and conveyor systems so that if a conveyor in a system or process is stopped, other equipment feeding it or the next may also be automatically stopped and Thus avoiding overloading at transfer points. For the safety of those who will come to the area where this equipment will operate we recommend that you contact an electrical designer and supplier. Provide them with information about your operating conditions so they can better advise and provide the appropriate devices.

HMI (HUMAN MACHINE INTERFACE)
FOR SCREW SANDBLASTING ROOM

HMI

ISTblast

FATEK

SCHNEIDER HMI INTERFACE



SCREEN SAVER MODE

ISTblast screen saver will display after 4 minutes of inactivity.

When touching it anywhere, the menu will display again.



AUTOMATIC MODE OPERATION MENU



1	Dust collector activation button
2	Dust collector stop button
3	Screw recovery system activation button
4	Screw recovery system stop button
5	Sandblasting system activation button
6	Sandblasting system stop button
7	Maintenance page access

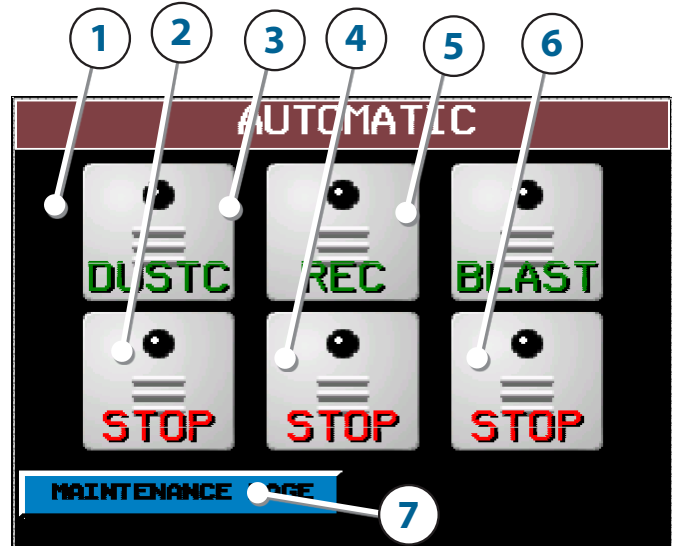

Green lights will display active systems

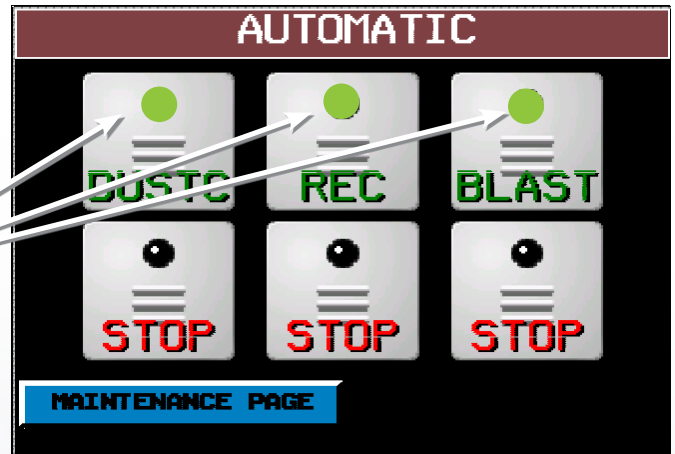

Red lights will be displayed momentarily when the Stop buttons have been pushed.

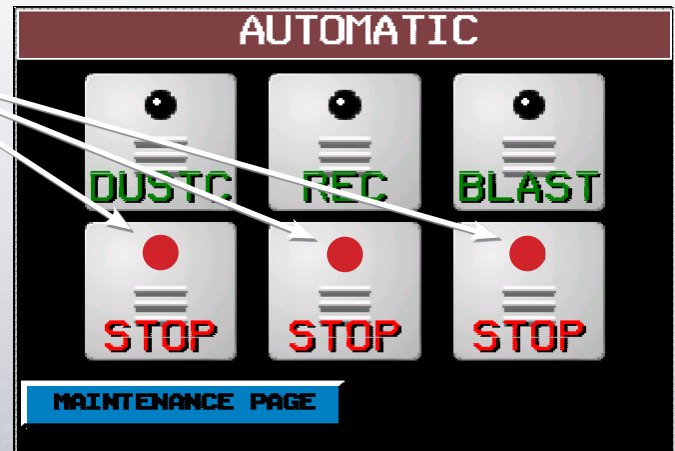

AUTOMATIC MODE OPERATION (END)



The green start up light for the Dust Collector System will begin to flash during start up.

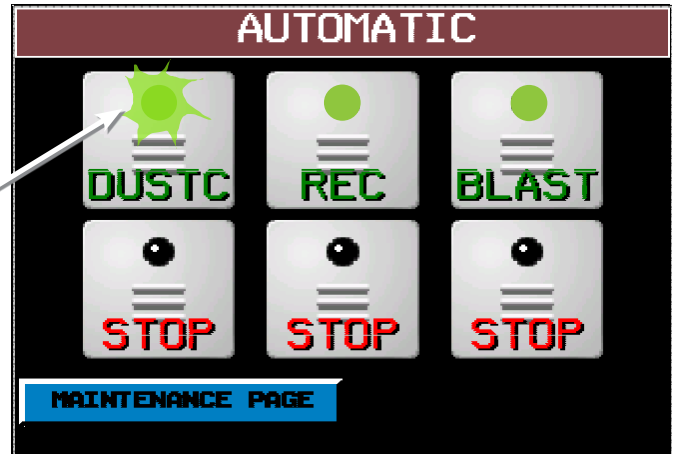

The green start-up light for the Pneumatic Conveyor and Recovery System will begin to flash to advise that the motors will be brought online.

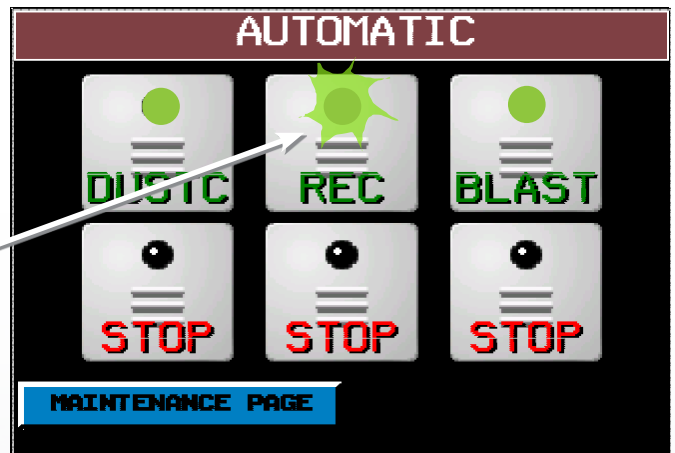

The red shut-down light for the Pneumatic Conveyor and Recovery System will begin to flash indicating that the motors will be shut down.

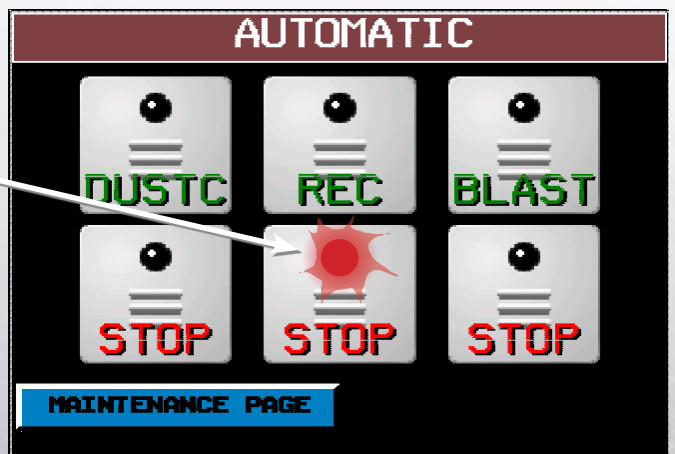

MAINTENANCE & MANUAL MODE



Maintenance Page

1	Access the Operation Screen under Automatic Mode
2	Access the Operation Screen under Manual Mode
3	Access the time meter menu
4	Access the adjustment menu
5	Access alarm history section
6	Change Password Section
7	Unlock to the protected operation screens

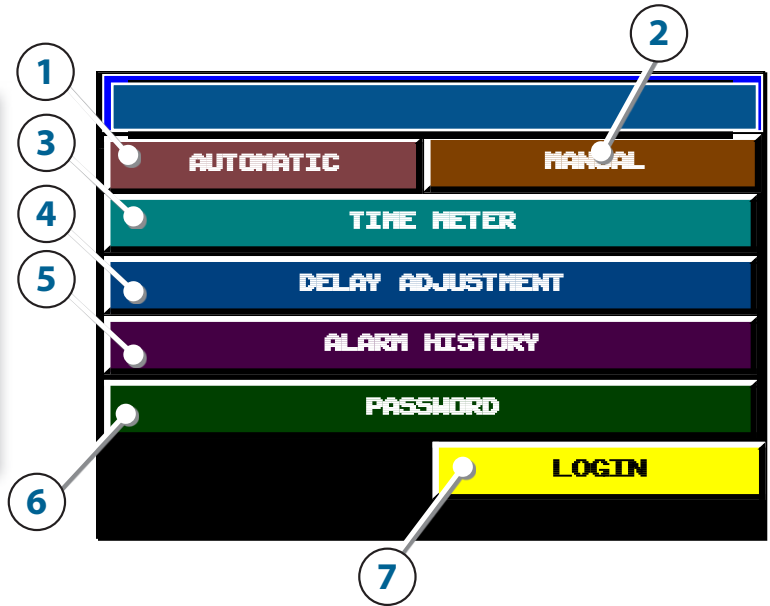

Manual Mode Operation Screen

1	Return to Maintenance page
2	Start the dust collector
3	Start the bucket elevator
4	Start the blasting system
5	Start the screw conveyors

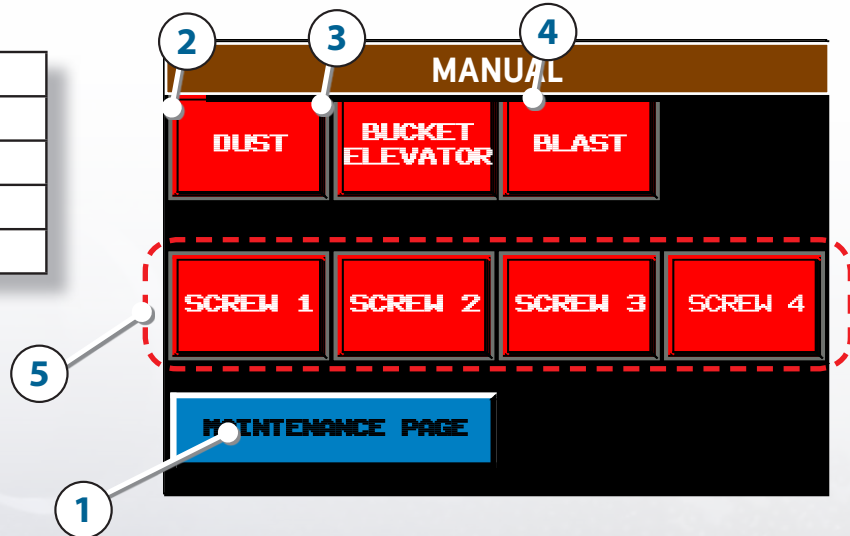

The redbuttons become green during manual mode operations.





DATE/TIME CHANGE MENU / ALARM HISTORY MENU

Date/Time Change Menu

When a value-field is selected a keyboard will be displayed to enter a value.

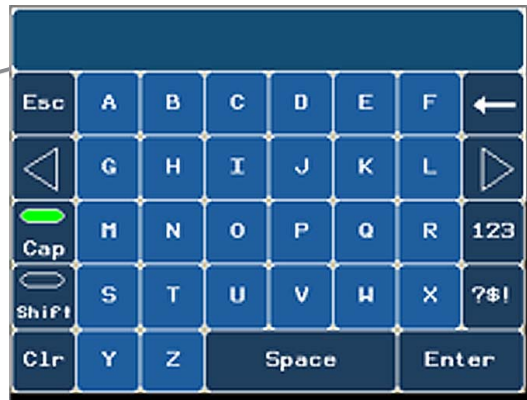
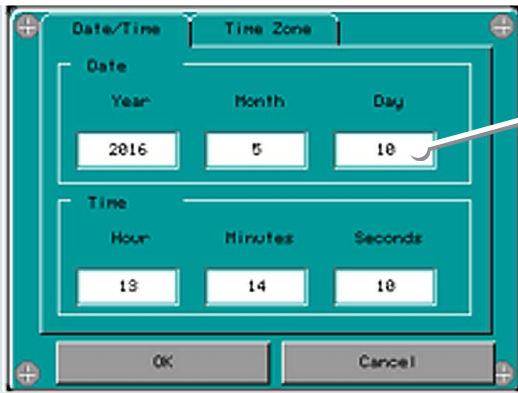

alarm history Menu

1	Return to Maintenance Menu
2	Error Message (Green type) (error resolved)
3	Error Message (Yellow type) (acknowledgement)
4	Error Message (Red type) (Error in Progress)
5	Move error message towards the top
6	Move error message towards the bottom
7	Previous Page
8	Subsequent Page
9	Acknowledgment of Error Message

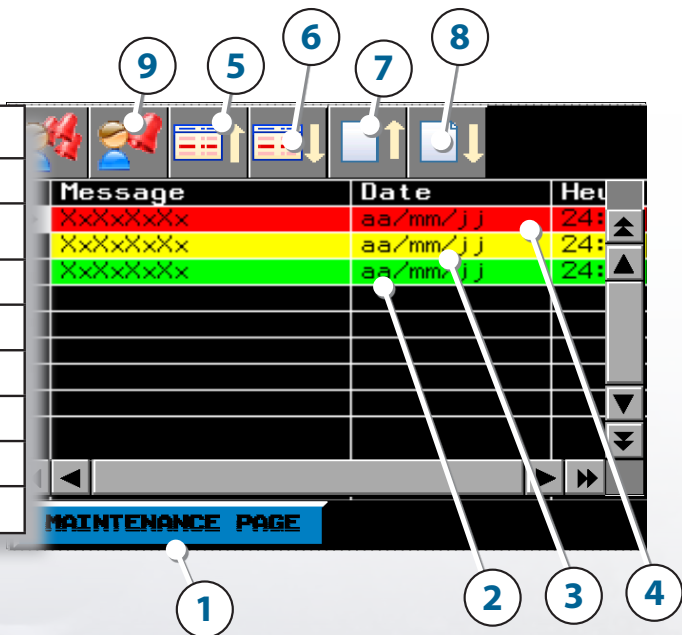

Possible Error Messages

EMERGENCY BUTTON
MEDIA HIGH
OVERLOAD Screw
OVERLOAD DUST COLLECTOR
EMERGENCY ROPE

CHANGE PASSWORD MENU

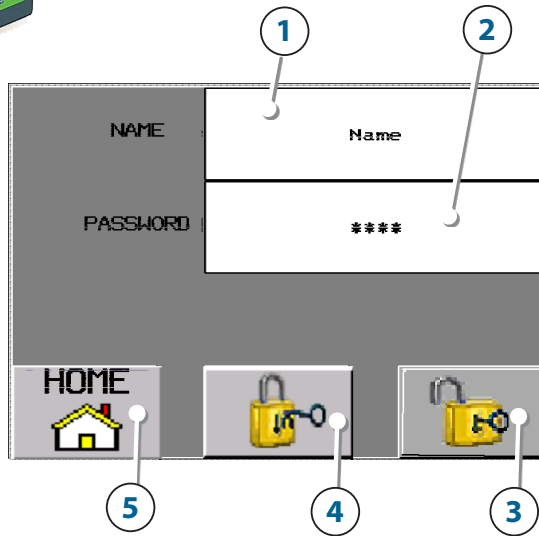

1	Enter Username
2	Enter password
3	Unlock Menu
4	Lock Menu
5	Return to Automatic-Mode Operations



When a value-field is selected a keyboard will be displayed to enter a value.

ALARM MENU

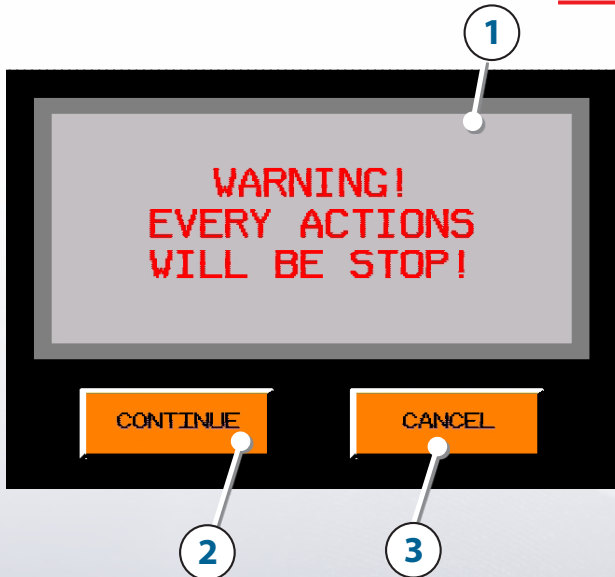

1	Warning display message
2	See list of possible error messages
3	Ignore error message

Possible Error Messages

EMERGENCY BUTTON
MEDIA HIGH
OVERLOAD SCREW200
OVERLOAD DUST COLLECTOR
EMERGENCY ROPE

FATEK HMI INTERFACE



SCREEN SAVER MODE

ISTblast screen saver will display after 4 minutes of inactivity.
When touching it anywhere, the menu will display again.





HMI (HUMAN MACHINE INTERFACE) - MAIN MENU

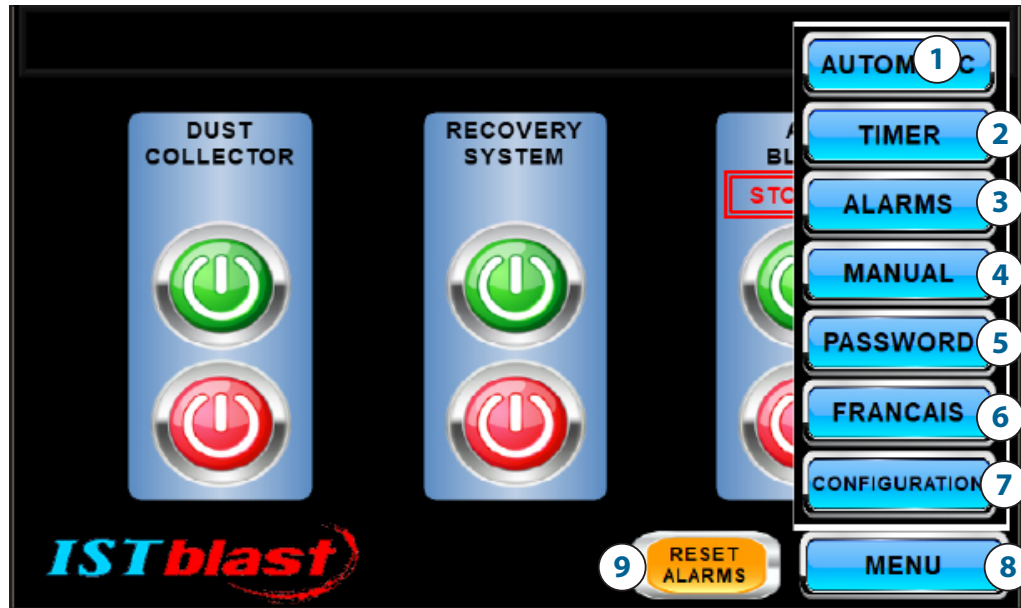

1	AUTOMATIC: Access the Automatic Mode Operation Screen
2	TIMER: Access the Timer Screen to adjust the start and stop delay of systems and to display the total count of operating hours of the system (requires a password)
3	ALARMS: Display all ongoing and fixed alarm notifications
4	MANUAL: Access the Manual Mode Operation Screen (requires a password)
5	PASSWORD: Modify users' passwords
6	FRANÇAIS: Switch the display language to French (requires a password)
7	CONFIGURATION: access to date and time adjustment (requires a password)
8	MENU: Access all available menus
9	RESET ALARMS: Reset all alarms (if required)

When a higher security level is required a login box will open to let the user enter a password.

Applicable to the following menu options:

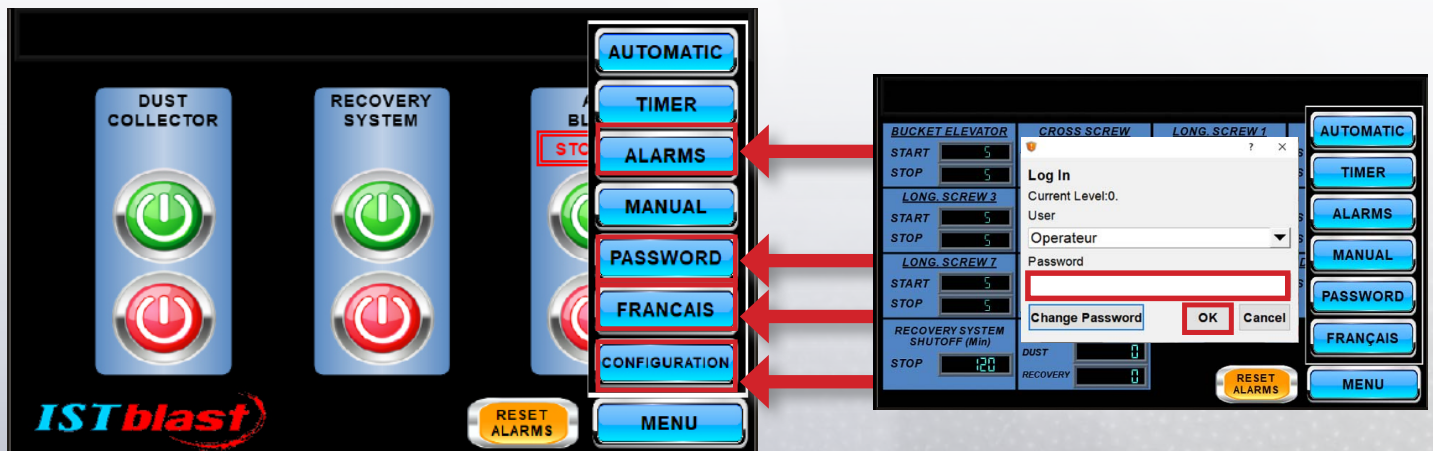

The system will automatically lock itself after one minute of inactivity

HMI - (HUMAN MACHINE INTERFACE) - USER ACCESS



1 AUTOMATIC MODE

Press the  button to activate a system. The case will indicate **[SEQUENCING]** for a few seconds while the system starts. Once the system is on, the case will display **[RUNNING]**.

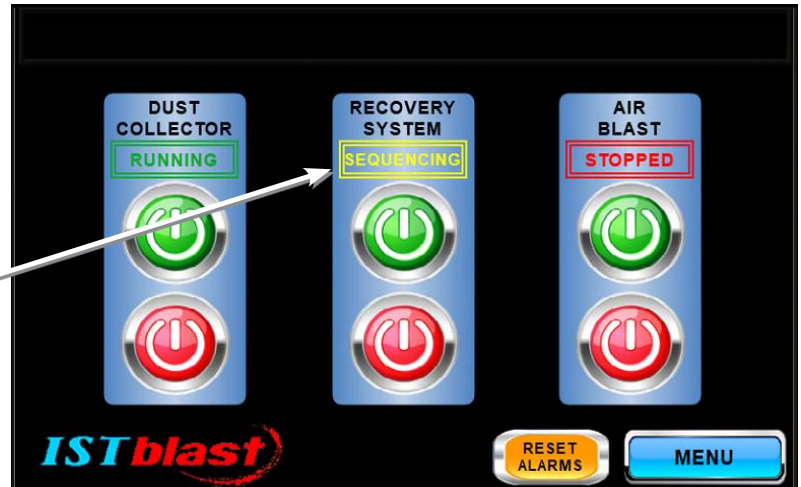

Alarm in progress will display at the top of the screen

Press the  button to stop a system. The case will indicate **[SEQUENCING]** for a few seconds while the system stops. Once the system is off, the case will display **[STOPPED]**

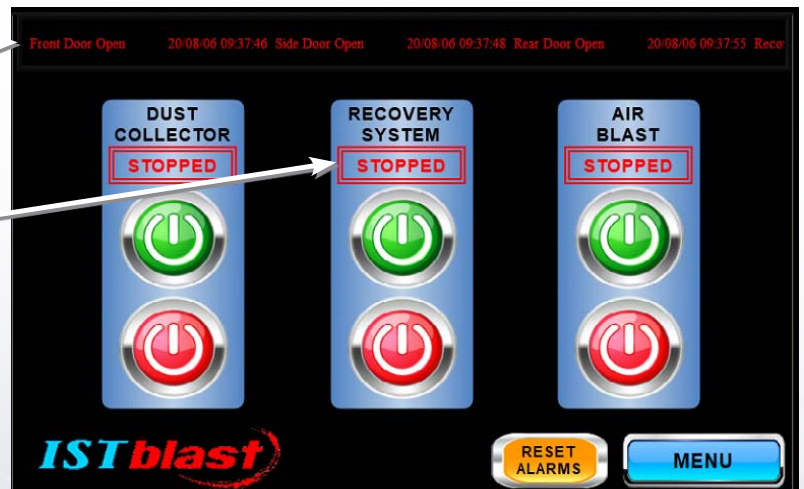

HMI (HUMAN MACHINE INTERFACE) - ADMIN. ACCESS



2 TIMER PAGE

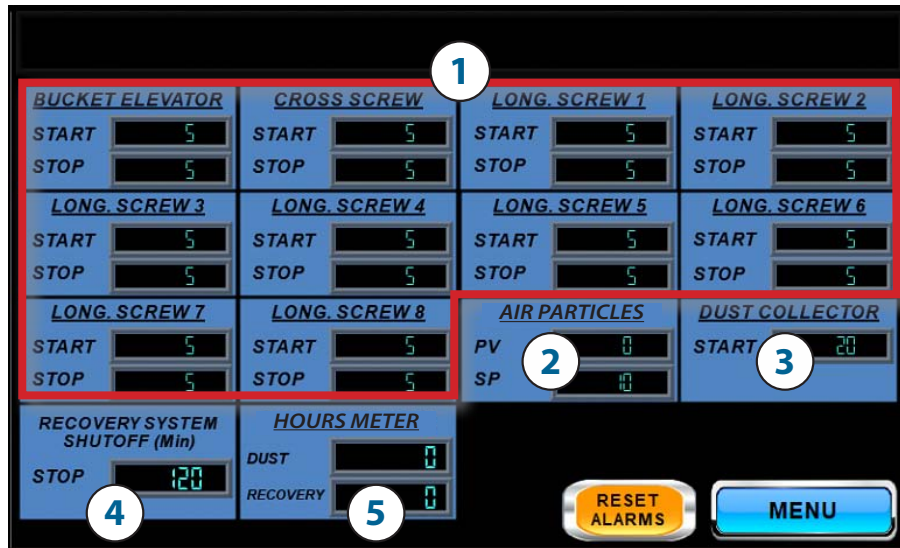

- | | |
|---|--|
| 1 | Adjust the start and stop delay of every system individually |
| 2 | If your dust collector is equipped with an air particulates detector, it allows you to set the high limit Set Point (SP) value after which the dust collector shuts off when the Particulate Value (PV) reaches that limit |
| 3 | Adjust the start delay of your dust collector |
| 4 | Adjust the recovery system shutoff delay |
| 5 | Display the total count of operating hours for maintenance purposes |

TOUCH ANY OF THESE CONTROL BOXES TO ADJUST VALUE BY USING THE POPUP KEYBOARD



HMI (HUMAN MACHINE INTERFACE) - USER ACCESS



3 ALARM MENU

Date	Trigger	Recovery	Message
20/08/06	09:08:35	09:13:33	Recovery System Time Out
20/08/06	09:08:35		!! FIRE !!
20/08/06	09:08:35		Hi Level Air Particules
20/08/06	09:08:35		Overload Longitudinal Screw #8
20/08/06	09:08:35		Overload Longitudinal Screw #7
20/08/06	09:08:35		Overload Longitudinal Screw #6
20/08/06	09:08:35		Overload Longitudinal Screw #5
20/08/06	09:08:35		Overload Longitudinal Screw #4
20/08/06	09:08:35		Overload Longitudinal Screw #3
20/08/06	09:08:35		Overload Longitudinal Screw #2
20/08/06	09:08:35		Overload Longitudinal Screw #1
20/08/06	09:08:35		Overload Cross Screw

At the bottom of the screen are two buttons: "RESET ALARMS" (yellow) and "MENU" (blue).

1	Error messages in green have been resolved
2	Error messages in red are in progress
3	Use scroll bar to scroll the page up/down
4	Press "Reset Alarms" to reset all alarms (if required)*
5	Return to menu

*** Unresolved alarms will remain active**

HMI - (HUMAN MACHINE INTERFACE) - ADMIN. ACCESS



4

MANUAL MODE OPERATION SCREEN

The MANUAL OPERATION Mode page allows the administrator and maintenance personal to operate each system individually.

USE CAUTION WHEN OPERATING IN MANUAL MODE! Improper sequence might cause severe damage to your system.



* The number of screws depends on the configuration of your floor.



HMI (HUMAN MACHINE INTERFACE) - ADMIN. ACCESS (CONT'D)

5

PASSWORD CHANGE MENU

The Password page allows the admin to modify users' password.



When a value-field is selected a keyboard will be displayed to enter a value.



HMI - (HUMAN MACHINE INTERFACE) - ADMIN. ACCESS



7 SYSTEM CONFIGURATION

The System Configuration menu allows you to set the system's parameters.

- **General:**Information about the HMI
- **Ethernet:** Allows you to set the PLC communication
- **Screen Saver:**Allows you to set the screen saver time delay
- **Date/Time:**Allows you to change the date and time

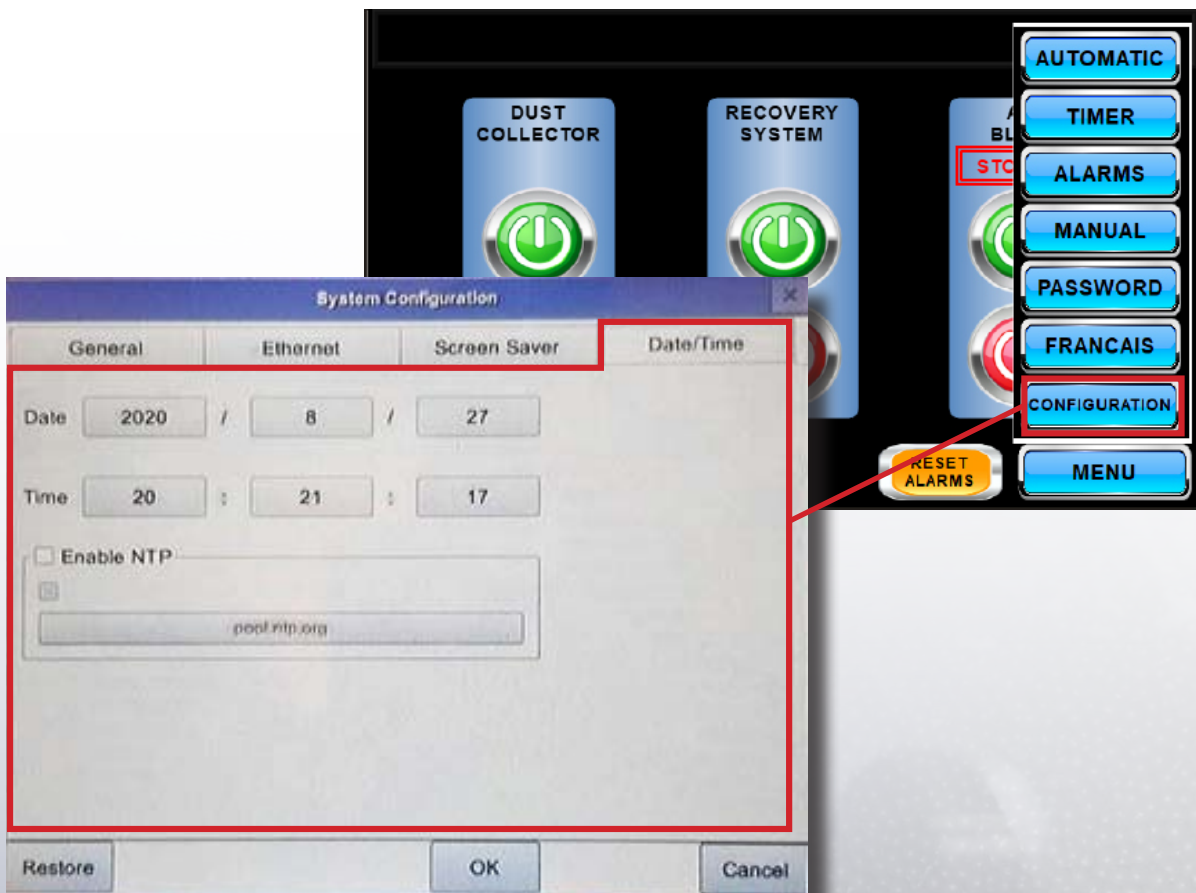



MAINTENANCE

SANDBLAST BOOTH - PREVENTIVE MAINTENANCE SCHEDULE

BOOTH ENCLOSURE

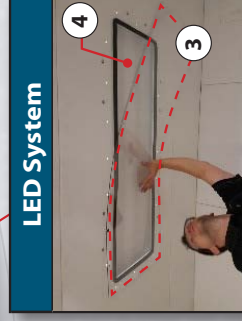
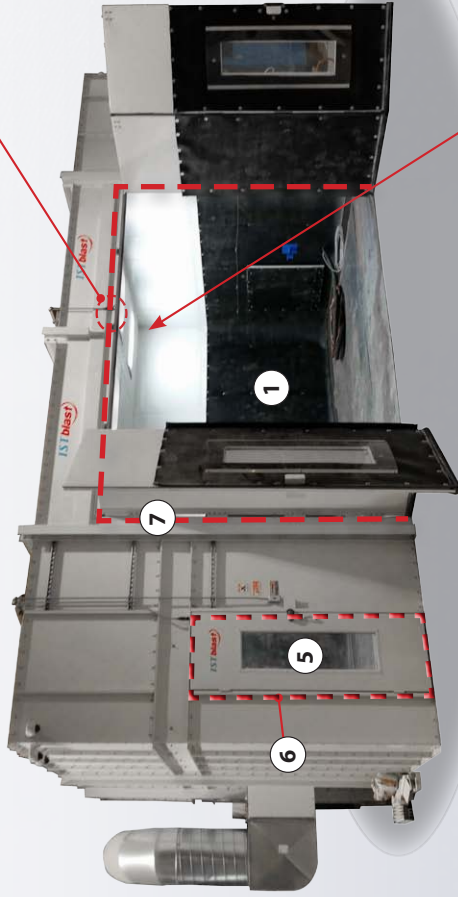

WEEKLY MAINTENANCE

1. **Rubber Lining** ①: Check for wear or deterioration of blast room rubber lining and replace when needed.
2. **Light System:** Clean frequently Light Lexan Cover ③ and replace when needed.
3. **Personal Men Door:** Clean frequently Door Lexan Window ④ and replace when needed. Make sure Door Seal ⑤ is airtight and replace when needed.

REPLACE WHEN NEEDED

DESCRIPTION	PART #
Rubber Lining (sold by square foot) ①	618330
Door Safety Switch ②	917586
Lexan Cover for Light ③	D900183S02
LED Light Fixture ④	617193
Lexan Door Window ⑤	613032
Door Seal ⑥ 1 $\frac{3}{4}$ " x $\frac{5}{8}$ " (12.5 ft)	618438
Main Door Seal ⑦ 1 $\frac{1}{4}$ " x $\frac{7}{8}$ " (45 ft)	618349



SANDBLASTING EQUIPMENT - PREVENTIVE MAINTENANCE SCHEDULE



- ### DAILY MAINTENANCE & OPERATION
- Inspect Personal Protective Equipment (PPE) ①. Service or replace when needed.
 - Arrange blast hose ⑤ in a way to avoid overlaps and steep curves.

- ### WEEKLY MAINTENANCE
- Inspect and service remote control handle and hose ②.
 - Inspect blast nozzle ③ and replace when needed.
 - Inspect whip blast hose ④ for leaks and replace when needed.

- ### MONTHLY MAINTENANCE
- Inspect blast hose ⑤, couplings ⑥ and gaskets for soft spots and premature wear. Replace when needed.
 - Inspect air hose ⑦, couplings and gaskets for soft spots and premature wear. Replace when needed.

- ### REPLACE WHEN NEEDED
- Refer to Nozzle, Hose, and Coupling Selection Guide on pages 66 & 67



ISTblast is a registered trademark of International Surface Technologies

346 Allée du Golf
Saint-Eustache (Québec)
J7R 0M8 Canada

T : 1 877 629-8202
F : 450 963-5122
info@istsurface.com

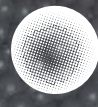

International
Surface
Technologies
istsurface.com

SCREW CONVEYOR SYSTEM -- PREVENTIVE MAINTENANCE SCHEDULE

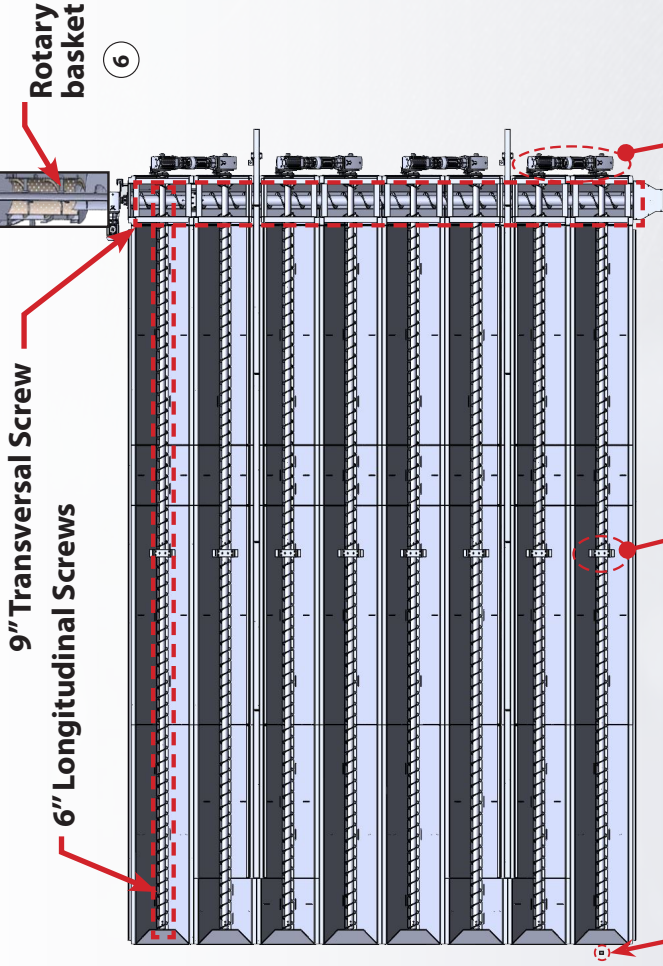

MONTHLY

- Lubricate **Ball Bearings** ④ and **Thrust Roller Bearings** ⑤
- Refer to name plate for oil type and volume required.
- Empty debris basket from **perforated screen drum** ⑥

EVERY 6 MONTHS

- Inspect every **Hanger Bearings** ① and **Coupling Shafts** ② for signs of wear. Both parts are self-lubricating and maintenance free. Replace when you notice signs of wear and/or when you hear a repetitive screeching noise.

EVERY 2,000 HOURS OF OPERATION

- Change oil on gear motor ③ Refer to name plate for oil type and volume required.

REPLACE WHEN NEEDED

DESCRIPTION	PART #
Hanger Bearing ①	919729
Coupling Shaft ②	900404
Gear Motor 2 hp / 480 V ③	916555
Gear Motor 2 hp / 600 V ③	916556
Flange-Mount Ball Bearing ④	900406
Thrust Roller Bearing ⑤	916557

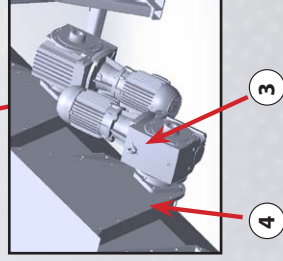

Ball Bearings

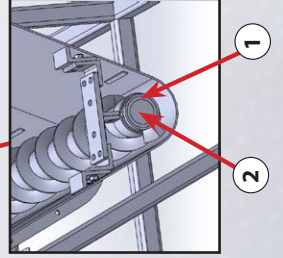

Roller Bearings

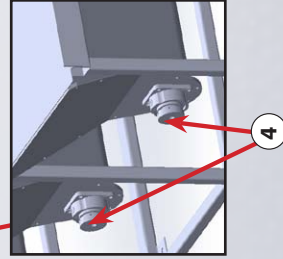

- ④ Bearings can vary from system to system. Refer to the picture to identify the part that is on your system.



SCREW CONVEYOR SYSTEM -- HANGER BEARING REPLACEMENT

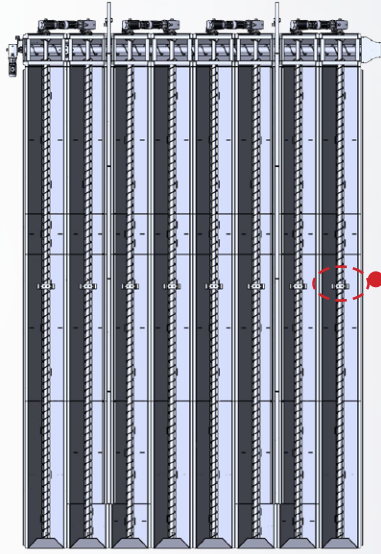

Hanger Bearing & Coupling Shaft

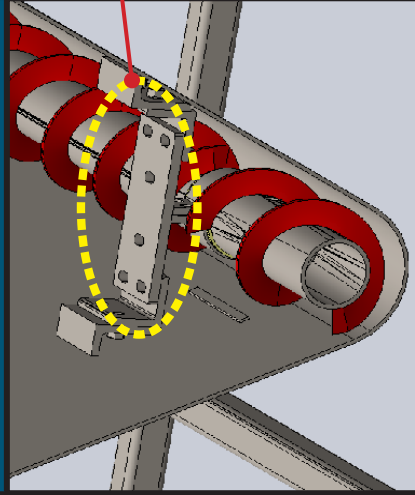

1. Remove the holding plate ① & "J" brackets ②.
 2. Remove the split hanger bearing ④.
 3. Clean the surface of the coupling shaft ③ using a fine emery cloth, as necessary.
 4. Put a new hanger bearing ④ in place. Use only original "Martin" cast iron oil impregnated.
- You don't need to change the coupling shaft unless it has signs of wear.

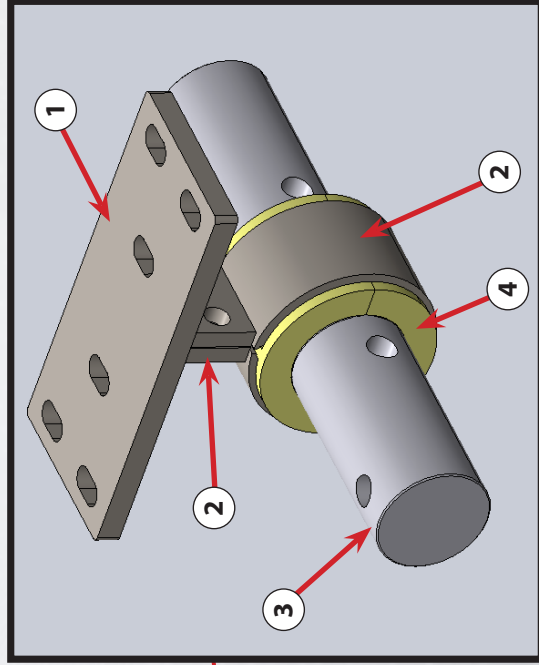

BUCKET ELEVATOR -- PREVENTIVE MAINTENANCE SCHEDULE

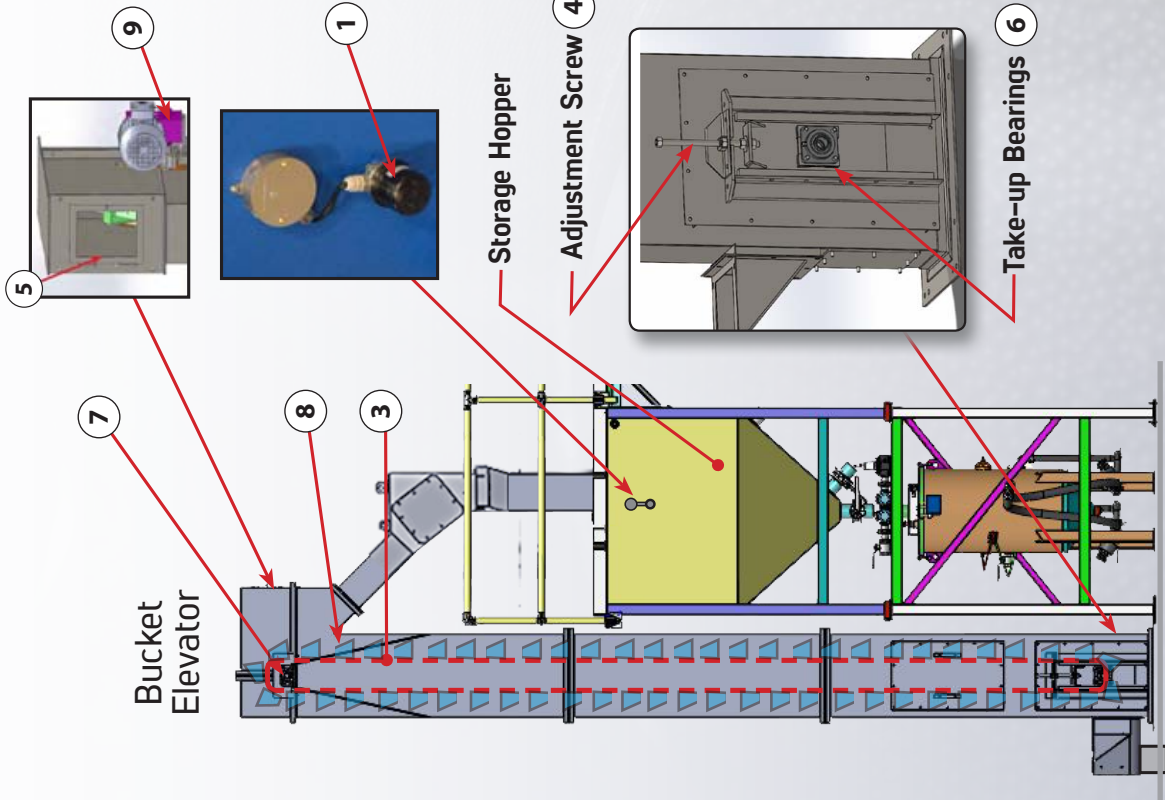

TENSIONING RUBBER BELT

- The rubber belt **1** must be tensioned 1 month after startup, and periodically thereafter.
- To adjust the tension on the belt, turn the adjustment screw **2** clockwise to increase tension or counterclockwise to release tension. The tension must be equal on both sides of the bucket elevator.
- Inspect the belt and the buckets through the service trap door **5**, and adjust tension accordingly.

1 MONTH AFTER STARTUP

- Adjust tension on rubber belt **1**.

MONTHLY

- Lubricate Take-Up Bearings **6** and Pillow Block Bearing **7** using multipurpose gear box grease. Replace when worn.

EVERY 2,000 HOURS OF OPERATION

- Change oil on gear motors. Refer to name plate for oil type and volume required. Replace when worn.
- Inspect the belt and the buckets through the service trap door **5**, and adjust tension accordingly. Replace belt or buckets when you notice signs of wear.

REPLACE WHEN REQUIRED

DESCRIPTION	PART NB.
Take-up roller bearing on the lift shaft 6	916558
Roller bearing on the shaft at the head of the elevator 7	924980



DUST COLLECTOR PREVENTIVE MAINTENANCE SCHEDULE

DCM 2,000 TO 50,000

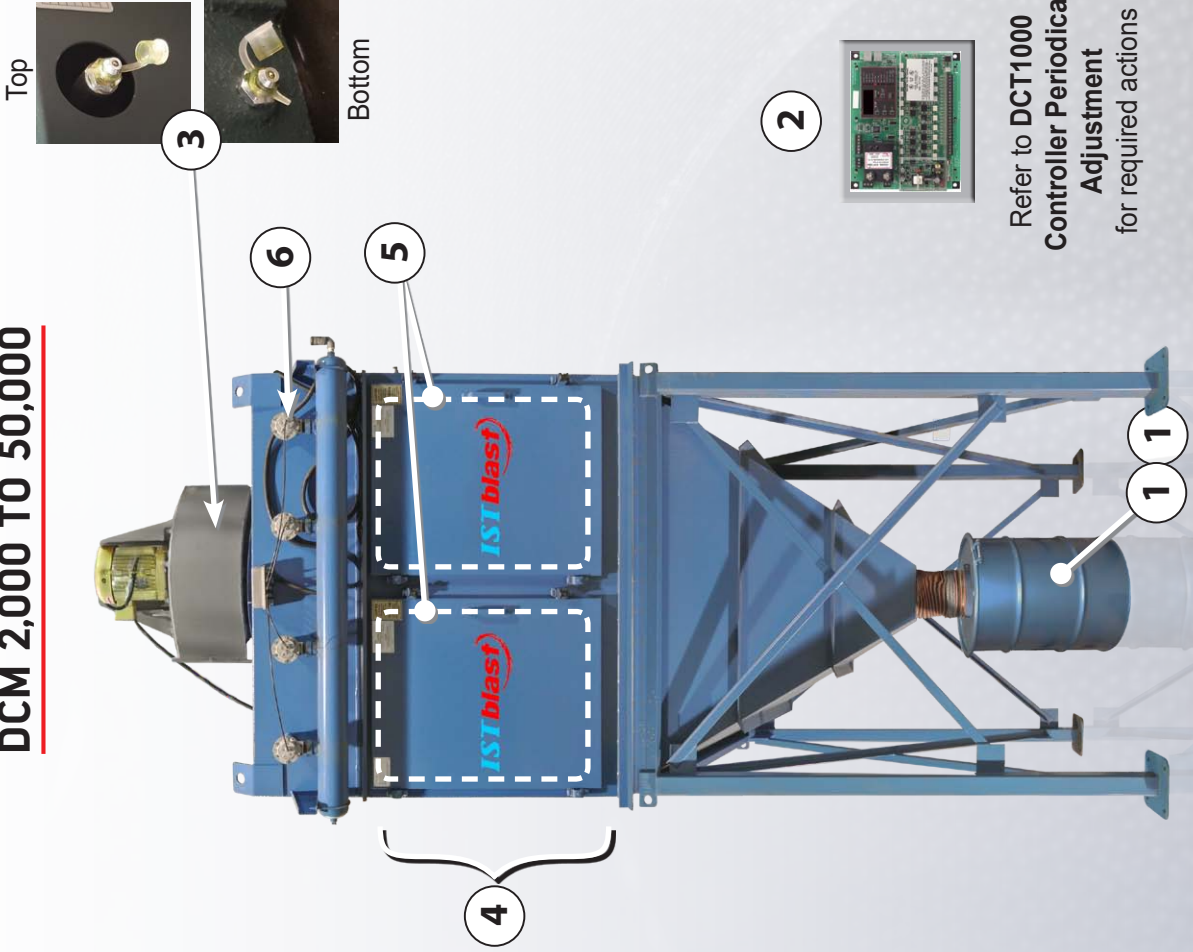

DAILY MAINTENANCE & OPERATION

Recuperation drum **1** : Check level every day and empty if needed

WEEKLY MAINTENANCE

Cartridges: and value displayed on the DCT1000 control panel **2**
 Replace cartridges as needed **4**

MONTHLY MAINTENANCE

Ducting: Check for leaks and wear, replace as needed
 Pulse Cleaning System: inspect Goyen Valves **6** , and replace or service as needed.

BI-ANNUAL MAINTENANCE

Motor **3**: Check motor bearings

DIAPHRAGM VALVE

SIZE	TYPE	COMPLETE VALVE	REPAIR KIT
1.5" (601329)	Goyen Valve	RCA-45T2	M-2162

REPLACE WHEN NEEDED (about every 3 years)

DESCRIPTION	PART Nb
Std. Cartridges 4 (each)	601307
Optional: Nanofiber Cartridges 4 (each)	601317
Door seal 5 (1/2" x 1") (sold by foot)	618305

Refer to DCT1000 Controller Periodical Adjustment for required actions



DCT1000 TIMER CONTROLLER - PERIODICAL ADJUSTMENTS

HOW IT WORKS

MONITORING OF PRESSURE DROPS

The DCT1000 monitors the static pressure differential between the clean and the dirty sides of cartridge filters – so-called pressure drop. As the filters load with dust, the resistance to air flow increases, and so does the pressure drop.

Brand new cartridge filter set will indicate a process value between **0.2 and 1.0**. During the first few hours of operation, dust will build up on the cartridges' pores in order to reach their optimal filtration capacities – this process is commonly referred to as the "dust cake".

Once the new cartridges are saturated with a dust layer, the normal operating value should be between **2 and 3.5** – which are the initial **Low Limit** and **High Limit** defined in the DCT1000.

High limit : 3.5
Low limit : 2.0

CARTRIDGE CLEANING

When the process value reaches the **High Limit**, the cleaning cycle starts emitting a series of pulses of air through each cartridge in order to dislodge exceeding amount of dust buildups. Pulses of air can be heard when the cycle is on.

During the cleaning cycle, the pressure drops should decrease on each pulse until it reaches the **Low Limit** which interrupts the cleaning cycle.

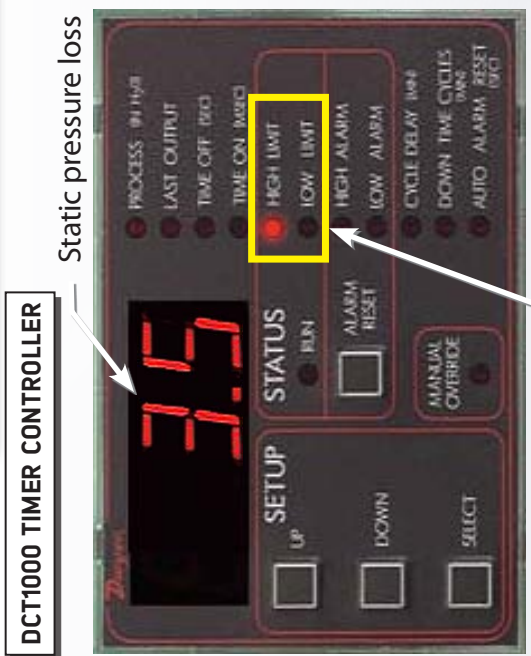

DCT1000 TIMER CONTROLLER

Static pressure loss

High limit / Low limit

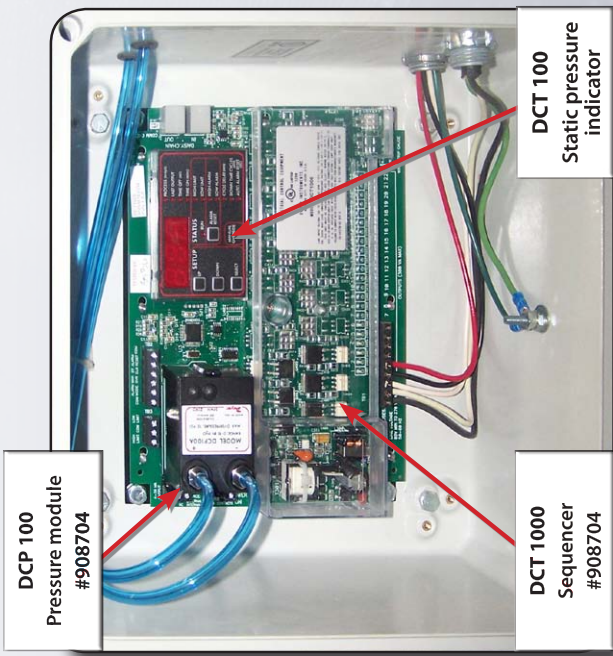

DCP 100 Pressure module #908704

DCT 1000 Sequencer #908704

DCT 100 Static pressure indicator

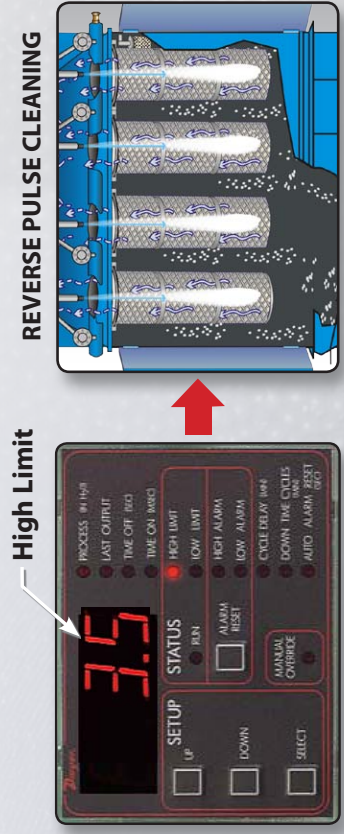

High Limit

Low Limit



ISTblast is a registered trademark of International Surface Technologies

346, Allée du Golf
Saint-Eustache (Québec)
J7R 0M8 Canada

T : 1 877 629-8202
F : 450 963-5122
info@istsurface.com

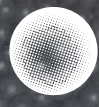

International Surface Technologies
istsurface.com

DCT1000 TIMER CONTROLLER - PERIODICAL ADJUSTMENTS

HOW IT WORKS

INITIAL VALUES

High limit : 3.5
Low limit : 2.0

→ Stagnant pressure drop



NEW VALUES

High limit : 3.9
Low limit : 2.4



Follow the procedure below in order to extend the life span of your cartridge filters while maximizing the filtration capacity of your dust collector.

When the cleaning process of the cartridges is no longer able to reach the **Low Limit** value, the cleaning cycle will run continuously.

At that moment, it is advised to increase the **Low Limit** and **High Limit** in order to extend the life span of the cartridge media to a certain limit.

Start increasing the **Low Limit** and **High Limit** of the cleaning process by 2 decimals above the stagnant value. For example, if the cleaning cycle runs continuously and the process value on the DCT1000 indicates **2.2**, set the new **Low Limit to 2.4** and the new **High Limit to 3.9**.

NEED TO REPLACE CARTRIDGES

FINAL VALUES

High limit : 8.5
Low limit : 7.0

Keep increasing moderately until your cartridges are incapable of reaching a **Low Limit of 7.0**. At that moment, it is time to change your cartridge filters and reset your process values to initial **Low Limit 2.0** and **High Limit 3.5**.

REPLACEMENT OF CARTRIDGE FILTERS

Change all your cartridge filters at the same time, regardless of their individual condition.

If you notice a damaged cartridge, immediately replace all your cartridge filters at once – if a cartridge filter is damaged and/or perforated, it may cause severe damage to your impeller and mislead the DCT1000 timer controller in its ability to control the cartridges cleaning cycles properly.

Refer to the owner's manual for parts number and changing procedure.

ADJUSTMENTS

Use the keys (Select) and (Up) (Down) you will be able to change some parameter

Note: Your unit has been programmed in the factory, if you change some settings be sure to write down the initial settings



SETTINGS

Process: Value displayed during operation of the fan (inches of water restriction cartridges)

Last Output: Number of active solenoid (this value can not be changed because the system auto-detects the number of active coil connected to the card)

Time Off: downtime between each pulse (value 10 seconds)

ON Time: Time pulse valves (value 250 milliseconds)

High Limit: The value to which the cleanup will begin (value between 2.5 and 3.5)

Low limit: The value to which the cleaning will stop automatically (value between 1.5 and 2.5)

High Alarm: Value must be reached to activate alarm (High limit value 2)

Low Alarm: Value must be reached to activate alarm (value = 0)

Cycle Delay: This value is to operate in manual mode (value = 0)

Down time cycles: This value is to operate in manual mode (value = 0)

Auto Alarm reset: This value is to operate in manual mode (value = 0)

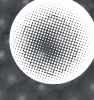

ABRASIVE METERING VALVE PMV-186 - ASSEMBLY / DISASSEMBLY PROCEDURES

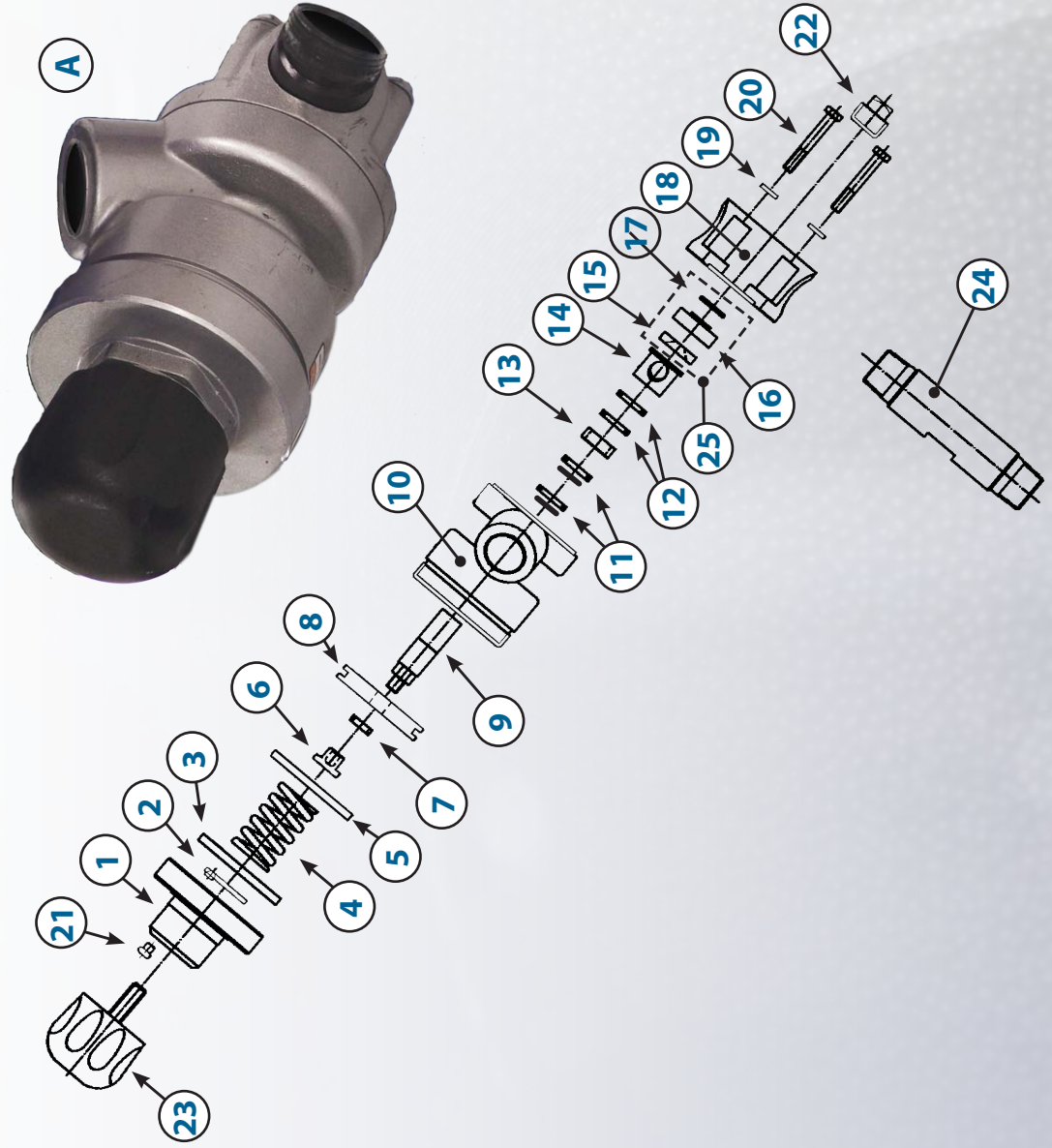

EXPLODED VIEW & PARTS NUMBERS









#	STOCK CODE	DESCRIPTION
A	608847	PMV-186 COMPLETE VALVE ASS'Y
1	770022	TOP
2	770201	ANTI-VIBRATION WASHER
3	770023	STOP RING
4	770024	SPRING
5	770213	PISTON SEAL
6	770202	PLUNGER STOP
7	770203	NYLON WASHER
8	770213	PISTON
9	770204	TUNGSTENE PLUNGER
10	770121	CYLINDER
11	608830	PLUNGER SEAL C/WITH O-RING
12	770030	PLUNGER SEAL C/WITHOUT O-RING
13	770206	PLUNGER BUSH
14	608832	TUNGSTEN CARBIDE SLEEVE
15	608840	URETHANE SEAT
16	608841	SEAT HOLDER
17	608839	O-RING
18	770032	BASE
19	770207	FLAT WASHER
20	770033	HEX HEAD BOLT
21	770208	EXHAUST FILTER
22	770209	SQUARE HEAD PLUG
23	770021	CONTROL KNOB
24	930185	1 1/2" X 1 1/2" PIPE NIPPLE
25	770211	TUNGSTEN SEAT KIT INCLUDE : #15, 16, 17
26	KIT 770210	INCLUDE ITEMS # 5,11,12, 13, 14, AND 15, 16, 17





COMPLETE DISASSEMBLY INSTRUCTIONS

- 



Loosen the 4 BOLTS (20) holding the BASE (18) to the PIPE NIPPLE (24) and remove the BASE (18). Be careful when removing the BASE (18) because the SLEEVE (14) can fall out of the PIPE NIPPLE (24) and break. (See Photo A)
- 

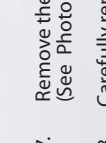
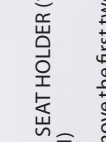
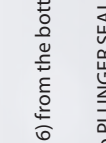

Remove the URETHANE SEAT (15), insert the SEAT HOLDER (16) and O-RING (17) from the BASE (18). (See Photo B)
- 

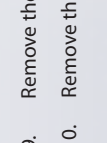
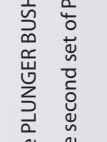
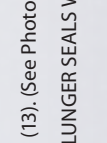

Slide the PIPE NIPPLE (24) out of the BASE (18) to remove it. (See Photo C)
- 



Remove the CAP (1) by unscrewing it counterclockwise using a wrench to expose the SPRING (4), BUMP RING (5), and PISTON ASSEMBLY (6-10). (See Photo D)
- 



Remove the PISTON (8) (See Photo E) and pull out the PISTON ASSEMBLY (6-10) by grabbing the PLUNGER STOP (6) with pliers. (See Photo F)
- 



Disassemble the PISTON ASSEMBLY (6-10) by removing the PISTON (8) with a pick tool being careful not to damage it. (See Photo G) Separate the PLUNGER (9), PLUNGER STOP (6), PISTON (8) and NYLON WASHERS (7) using 2 wrenches. (See Photo H)

COMPLETE ASSEMBLY INSTRUCTIONS

- 



Apply Blue Threadlocker to the threads on the PLUNGER (9). (See Photo M)
- 



Assemble the Piston Assembly by stacking the PLUNGER (9), PISTON (8), NYLON WASHERS (7) (2 required) and PLUNGER STOP (6). Tighten the assembly with 2 wrenches being careful not to overtighten and crush the washers. (See Photo N)
- 



Install PISTON SEAL (5) with open side facing the PLUNGER (9). (See Photo O)
- 



Lubricate the inner wall of the CYLINDER (10) with Anti-Seize Lubricant. (See Photo P)
- 



Slide the PISTON ASSEMBLY (6-10) into the CYLINDER (10) until it bottoms out keeping it square with the side of the CYLINDER (10) so the PISTON ASSEMBLY (6-9) does not bind against the CYLINDER (10) wall. (See Photo Q)
- 



Re-apply Anti-Seize to the CYLINDER (10) after inserting the PISTON ASSEMBLY (6-9). (See Photo R)
- 



Insert the BUMP RING (4) into the CYLINDER (10) and reinstall the CAP (1) and SPRING (4), and tighten with a wrench. (See Photo S)
- 



Install the first PLUNGER SEAL W/O-RING (13) by sliding it over the PLUNGER (9) with the open side of the seal first using a pick tool to help the outer edge into the CYLINDER (10). (See Photo T)
- 

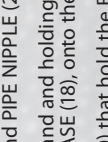

Press the PLUNGER SEAL W/O-RING (11) into the CYLINDER (10) using the SEAT HOLDER (16) as far as it will go, then insert the second PLUNGER SEAL W/O-RING (11) following the same procedure. (See Photo U)
- 



Insert the PLUNGER BUSHING (13) into the CYLINDER (10) and press into place using the SEAT HOLDER (16). (See Photo V)
- 



Install the two PLUNGER SEALS (15) without O-rings closed side first by inserting them one at a time around the PLUNGER (9) and pushing them each into place with the SEAT HOLDER (16). (See Photo W)
-

Install the SEAT HOLDER (16) into the CYLINDER (10) by aligning the notch in the SEAT HOLDER (16) with the alignment pin in the CYLINDER (10) and pressing it firmly in place (See Photo X).
-

Insert the PIPE NIPPLE (24) into the BASE (18) aligning the flat area on the PIPE NIPPLE (24) with the opening on the BASE (18). (See Photo Y)
-

Install the SEAT HOLDER (16), O-RING (17) and URETHANE SEAT (15) into the BASE (18) making sure the insert is flush with the BASE (18) and PIPE NIPPLE (24). (See Photo Z)
-

With the BASE (18) in one hand and holding the SEAT HOLDER (16) and URETHANE SEAT (15) in place with the other hand, place the BASE (18) onto the CYLINDER (10). (See Photo AA)
-

Hand-tighten the BOLTS (20) that hold the BASE (18) to the CYLINDER (10), then using a wrench or socket, tighten them securely in an "X" pattern. (See Photo BB)



ABRASIVE-METERING VALVE AR7 + A6 - ASSEMBLY / DISASSEMBLY PROCEDURES

EXPLODED VIEW AND PARTS NUMBERS

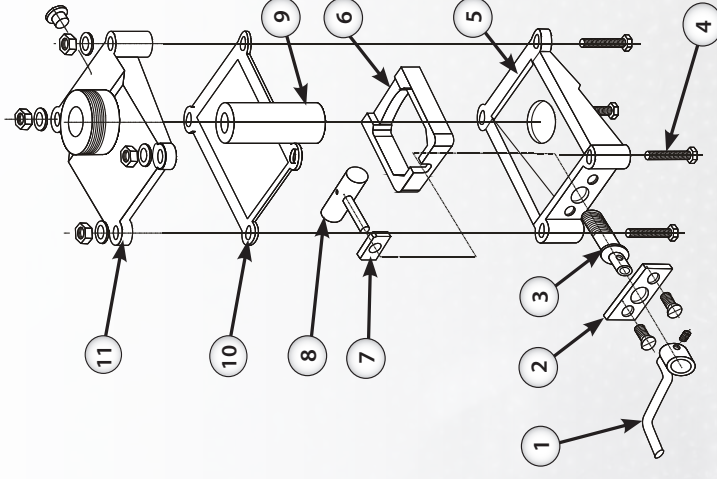

A	608043	Complete AR-7 Abrasive regulator
1	608093	Handle
2	608091	Retaining plate
3	608039	Regulating screw
4	608096	Bolt kit
5	608047	Lower housing
6	608037	Pinch roller
7	608040	Regulating plate
8	608036	Regulation tube
9	618228	Rubber tube
10	618231	Gasket
11	608046	Upper housing

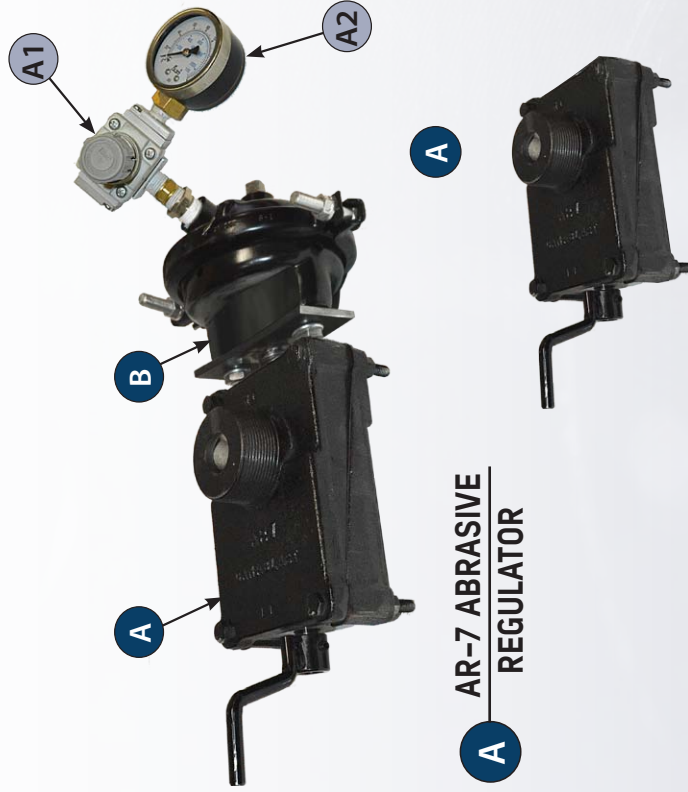

A AR-7 ABRASIVE REGULATOR

*Note: you can adjust the A6 pressure control by using the pressure regulator **A1** and checking it on the pressure gauge **A2***

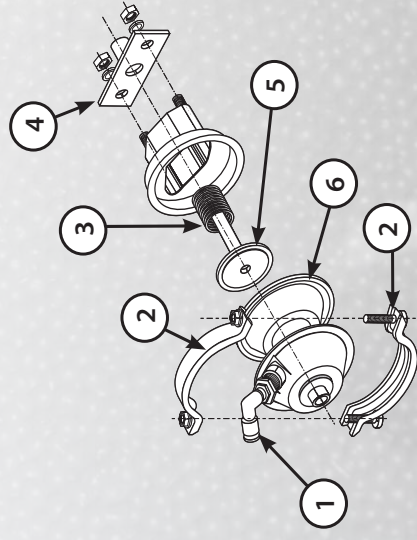

B	608482	Complete A6 Actuator
1	324560	Push-in 1/4" @ 90°
2	608488	Retaining collar
3	608487	Spring
4	608481	Retaining plate
5	608480	Push rod
6	618216	Diaphragm



B A6 ACTUATOR

See Assembly / Disassembly on the back

AR-7 COMPLETE DISASSEMBLY/ASSEMBLY INSTRUCTIONS

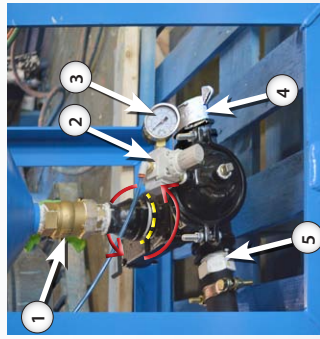

1. Close Completely the Ball Valve ①
 2. Release pressure by turning the Pressure Regulator ② until the pressure displayed on the Pressure Gauge ③ fall to zero.
 3. Turn the AR-7 lever clockwise until end of course.
 4. Unplug the Quick Connect ④ and unscrew the hose swivel insert ⑤
 5. Now you can remove the AR-7 + A6 by unscrewing it from the adaptor.
 6. Loosen the 4 bolts ⑥ holding the 2 parts of the housings and separate them.
 7. Remove the regulation tube ⑦ and replace it with a new.
- Before reassembling the AR-7 check the gasket ⑧ and replace it if necessary.
8. Replace the AR-7 + A6 kit and restore the pressure to initial value if required. **Must be at 70 psi max.**

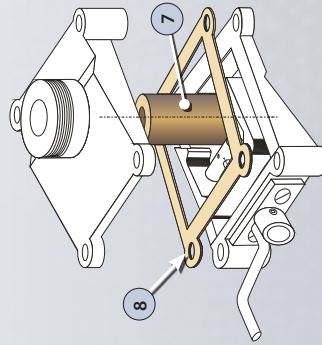
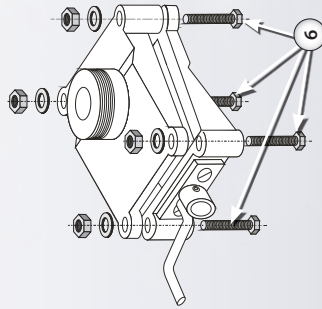

A6 COMPLETE ASSEMBLY/DISASSEMBLY INSTRUCTIONS

1. Close Completely the Ball Valve ①
2. Release pressure by turning the Pressure Regulator ② until the pressure displayed on the Pressure Gauge ③ fall to zero.
3. Turn the AR-7 lever clockwise until end of course.
4. Unplug the Quick Connect ④ and unscrew the hose swivel insert ⑤
5. Now you can remove the AR-7 + A6 by unscrewing it from the adaptor.
6. Loosen the 2 bolts ⑨ to separate the A6 from the AR-7.
7. Loosen the 2 bolts ⑩ holding the 2 parts of the housings and separate them.
8. Check if the diaphragm ⑪ is worn and replace it with a new if required.
9. Check also the push rod ⑫ and if it is worn replace it with a new.
10. Close up the A6 and reassemble it with the AR-7 and restore the pressure to initial value if required. **Must be at 70 psi max.**

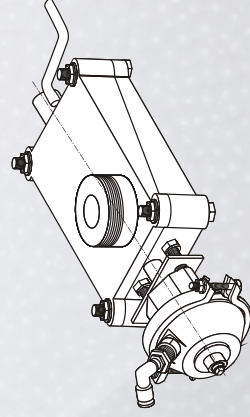
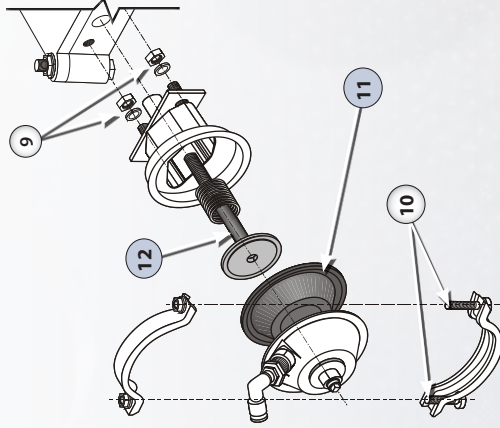

for complete parts details, see front page.



ABRASIVE-METERING VALVE AV186 - ASSEMBLY / DISASSEMBLY PROCEDURES

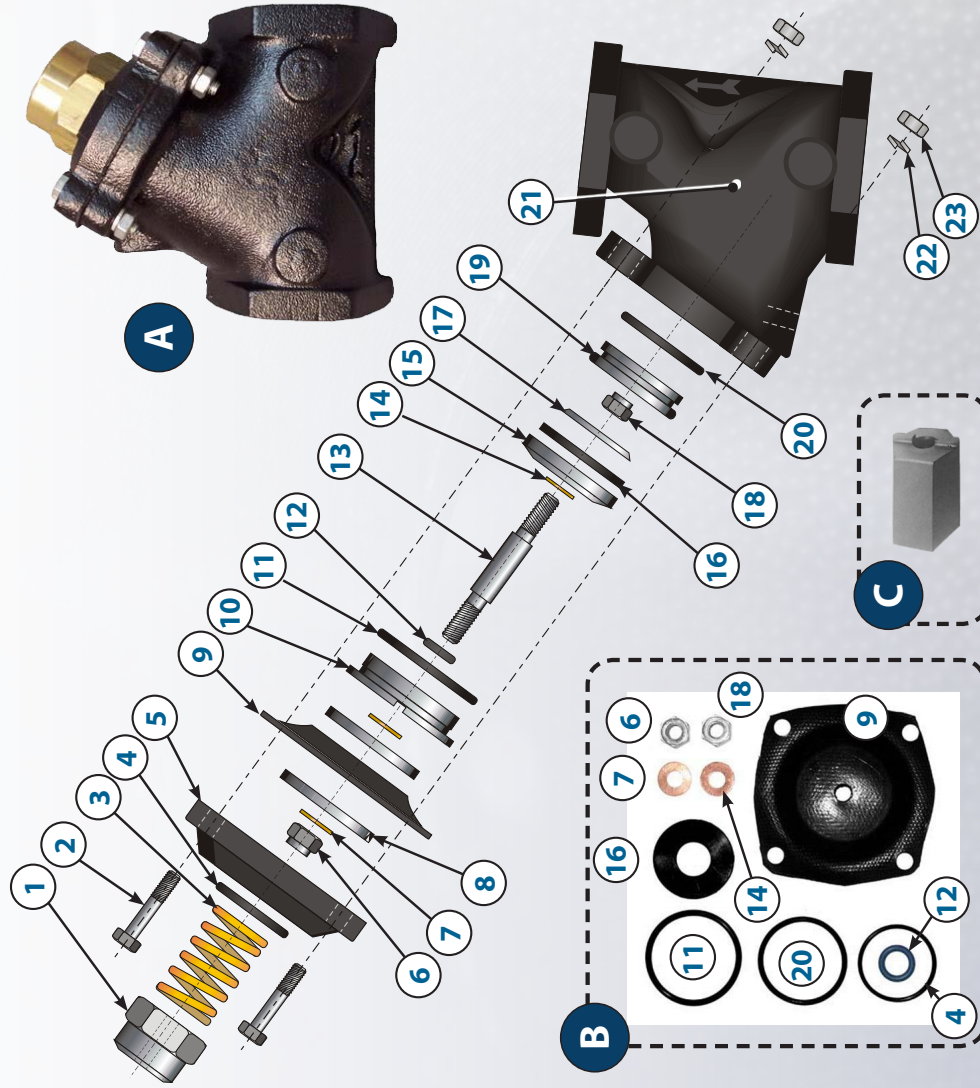

#	DESCRIPTION	1 1/4" Ø	1 1/2" Ø
A	AV-186 AIR VALVE: COMPLETE VALVE ASSEMBLY	608822	908846
B	SERVICE KIT INCLUDES ITEMS : 4, 6, 7, 9, 11, 12, 14, 16, 18, 20	608823	908944
C	SERVICE KIT INCLUDING THIS TOOL	608823A	908944A

#	DESCRIPTION	QTY
1	CAP	1
2	HEX MACHINE SCREW 1/4" UNC X 35 MM	4
3	608825 SPRING	1
4	O-RING 31.5 mm x 2 mm	1
5	CAP	1
6	LOCK NUT 5/16" UNF	1
7	FLAT WASHER 8 mm	2
8	FLAT WASHER	2
9	DIAPHRAGM	1
10	608826 GUIDE BUSH	1
11	O-RING 45 MM X 3 MM	2
12	O-RING 9 MM X 2.65 MM	2
13	SHAFT	1
14	FLAT WASHER	1
15	608955 SEAT HOLDER	1
16	NPN RUBBER GASKET	1
17	608954 RETAINER	1
18	NPN LOCK NUT 1/4" UNF	1
19	NPN INNER BUSH	1
20	NPN O-RING 34 MM X 1.8 MM	1
21	NPN BODY	1
22	NPN SPRING WASHER 1/4"	4
23	NPN NUT 1/4" UNC	4

11/2" Ø 1 1/4" Ø # PART # DESCRIPTION QTY

ISTblast is a registered trademark of International Surface Technologies

346 Allée du Golf
Saint-Eustache (Quebec)
J7R 0M8 Canada

T : 1 877 629-8202
F : 450 963-5122
info@istsurface.com

International Surface Technologies
istsurface.com

2022-02-15



PRESSURE VESSELS - PREVENTIVE MAINTENANCE SCHEDULE

ABRASIVE BLAST ROOM PRESSURE VESSEL

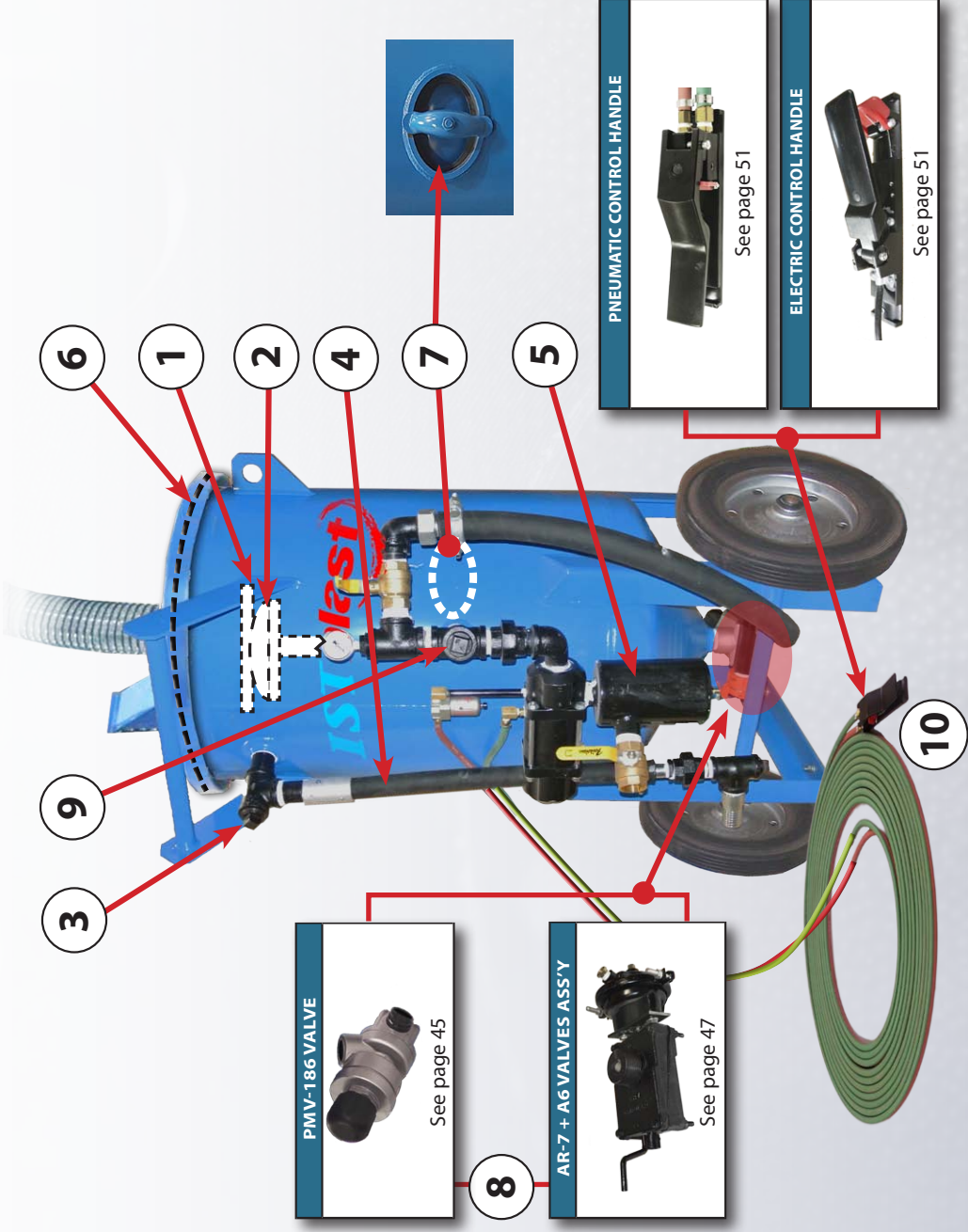

- DAILY**
- Empty water separator **5**
 - Inspect remote control handle and service as needed **10** see page 52

- WEEKLY TO MONTHLY**
- Verify the inside the plug **3**, replace when needed
 - Verify the depressurizing hose at pinch point **4**
 - Verify the plunger for excessive wear and air leaks when the vessel is pressurized **2**
 - Verify the O-Ring for excessive wear and air leaks when the vessel is pressurized **1**
 - Inspect abrasive metering valve and replace or service when needed **8** :
 - AR-7/A6 – Check for regulation tube of AR-7 and adjust the pressure of A6 to 70 psi (see page 47)
 - PMV-186 – Check for the seat and piston to ensure proper functioning of the valve, check for air/media leaks at the nozzle while the remote controlled is not engaged (see page 46)
 - Check for leaks on AV-186 air valve and service as needed **9** (see page 49)

- 12 MONTHS**
- Verify integrity of the cover sealing gasket **6**
 - Verify integrity of the trap sealing gasket **7**

NOTE : Refer to owner's manual for complete part list of the pressure vessel. Address maintenance procedure to any air leaks occurring in between the schedule maintenance.

REMOTE CONTROL HANDLES - ASSEMBLY / DISASSEMBLY PROCEDURES

ELECTRIC CONTROL HANDLE

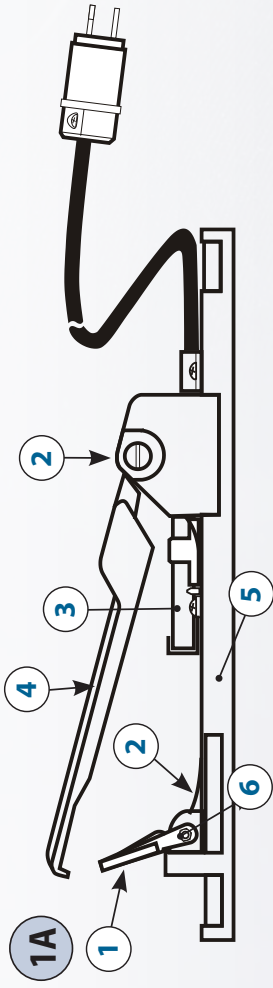

#	STOCK	DESCRIPTION
1A	770160	Complete electric control handle
1	770051	Safety level
2	770052	Spring
3	770063	Switch
4	770054	Handle
5	770055	Base
6	770060	Shoulder screw

PNEUMATIC CONTROL HANDLE

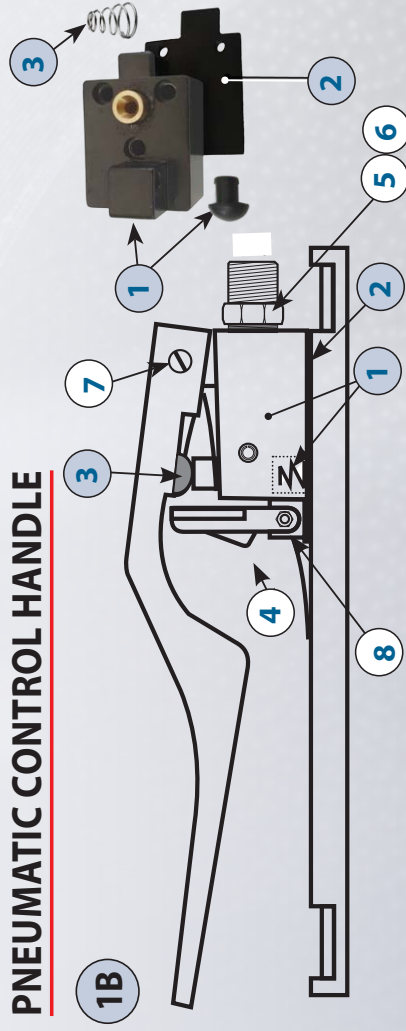

#	STOCK	DESCRIPTION
1B	908006	Complete pneumatic control handle
1	770061	Repair kit for control handle
2		
3		
4	770062	Safety flap
5	632214	Hex. nipple 1/4" NPT x 1/8" c/w ball ST
6		Hex. nipple 1/8" NPT x 1/4" c/w ball ST
7	770052	Spring
8	770060	Shoulder screw

FITTINGS, HOSES & NOZZLES SELECTION GUIDE

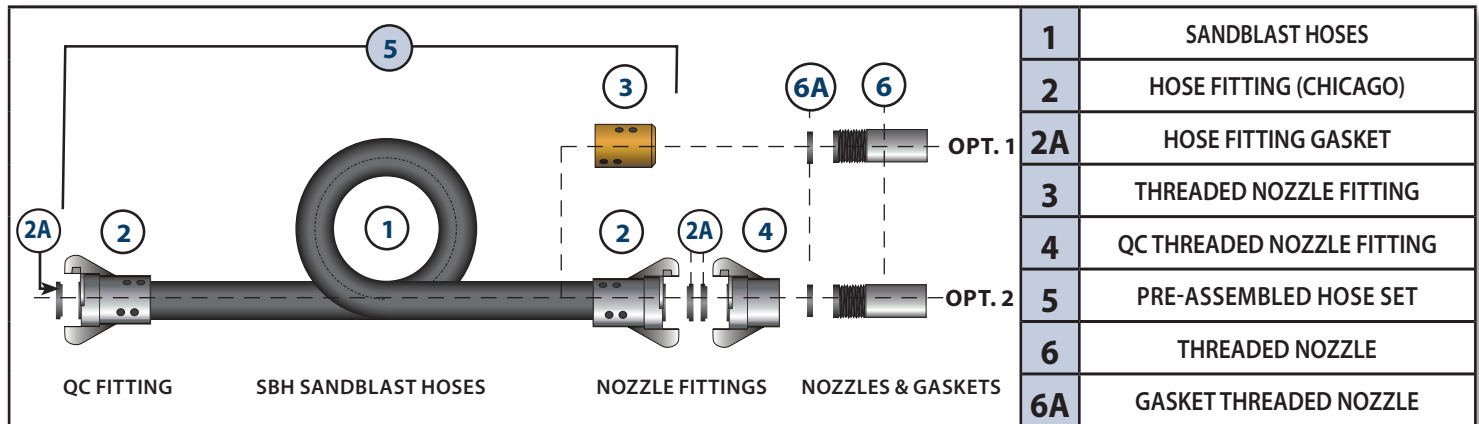

BULK SANDBLAST HOSES (LENGTH OF 12.5', 25' & 50' ONLY)

		MODEL	INSIDE DIAMETER	OUTSIDE DIAMETER	
	1	606004	SBHW-1 ¼" whip	1 ¼"	1 ⅞"
		606005	SBH-1"	1"	1 ⅜"
		606006	SBH-1 ¼"	1 ¼"	2 ⅝"
		606007	SBH-1 ½"	1 ½"	2 ⅜"
		606008	SBH-2"	2"	2 ⅞"

HOSES FITTINGS

	Part Nb.	Model	SBH I.D.	SBH O.D.
 (CHICAGO)	2	607005	1"	1 ⅜"
		607007	1¼"	2 ⅝"
		607009	1½"	2 ⅜"

FITTING GASKETS*

	Part Nb.	Model	Hose I.D.
	2A	618000	1"
		618001	1¼"
		618003	1½"

* The gasket is included with hose fittings.

OPTION 1: THREADED NOZZLE FITTINGS

	Model	Hose I.D.	Thread		
			1"-¼ NPS	2"-4½ UNC	
	3	NH-1	1"	607018	407020
		NH-1¼	1¼"	607019	407021
		NH-1½	1½"	607054	407010

OPTION 2: QUICK CONNECT NOZZLE COUPLINGS

	Part Nb.	Model	Hose I.D.	Thread
	4	607075	1¼"	1"-¼ NPS
		907011	1½"	

Nozzle couplings are primarily used by operators who need to regularly change nozzles, but this type of connection could cause wear on the hose and / or nozzle.

FITTINGS, HOSES & NOZZLES SELECTION GUIDE (CONT'D)

5 HOSE AND FITTINGS PRE-ASSEMBLED KITS (INCLUDES 1, 2 AND 3)



Kits with two hose connections (QC-QC) to the end pieces can be used to make extensions. Assemblies that include a hose connector (QC) and a nozzle connector (NH) are those used to insert the nozzle.

The SBHW-1/4" Whip hose offers lightness and flexibility in use, but wears out faster because its wall is thinner than standard hoses. The Whip system is generally used at the "last length" blast hose in blast chambers and should be replaced more frequently.

1 SANDBLASTING HOSE			2 3 FITTINGS	
Model	Inside Diam. (I.D.)	Hose length (feet)	QC-QC	QC-NH
SBH-1"	1"	12.5	606030	606029
		25	606036	606031
		50	606037	606032
SBH-1 1/4"	1 1/4"	50	606042	606040
SBH-1 1/2"	1 1/2"		606052	606050
SBHW-1/4"	1/4" Whip	12.5	606049	606053

6 THREADED NOZZLES SIMPLE VENTURI

Simple Venturi nozzles provide exceptional sanding performance. Their design is designed with a narrow entrance and a wide opening which considerably increases the velocity at the exit

DCV- TUNGSTEN CARBIDE*	Part #	Model	Orifice	Length	Thread	
	605203	DCV-3	3/16" Ø	4 1/4"	1 1/4" NPS	
	605204	DCV-4	1/4" Ø	5 1/4"		
	605205	DCV-5	5/16" Ø	6"		
	605206	DCV-6	3/8" Ø	6 3/4"		
	605207	DCV-7	7/16" Ø	8"		
	605208	DCV-8	1/2" Ø	9 1/4"		
BCV4- BORE CARBIDE*	Part #	Model	Orifice	Length		Thread
	605453	BCV4-3	3/16" Ø	4 1/8"		1 1/4" NPS
	605454	BCV4-4	1/4" Ø			
	605455	BCV4-5	5/16" Ø			
	605456	BCV4-6	3/8" Ø			
	605458	BCV4-8	1/2" Ø			

6 GASKET	Part #	Model	Thickness
	618016	NW-1	1/4"

* The gasket is included with the nozzles.

THREADED NOZZLES DOUBLE VENTURI

Double Venturi nozzles provide increased performance compared to the Single Venturi nozzle. The hole inside the nozzle allows atmospheric air to be introduced, which considerably increases the velocity while reducing the loss of velocity.

BCV- BORE CARBIDE*	Part #	Model	Orifice	Length	Thread
	405464	BCV-4	1/4" Ø	5 5/16"	2"-4 1/2" UNC
	405465	BCV-5	5/16" Ø	6 1/16"	
	405466	BCV-6	3/8" Ø	6 1/8"	
	405467	BCV-7	7/16" Ø	8 15/32"	
	405468	BCV-8	1/2" Ø	9 1/16"	

6 GASKET	Part #	Model	Thickness
	407025	NW3	1/4"

* Gasket sold separately.



SAFETY EQUIPMENT

AIR BREATHING – PROTECTIVE EQUIPMENT FOR THE OPERATOR

Abrasive blasting operators are equipped with Personal Protective Equipment (PPE) and respiratory equipment (RPE) to ensure the user is protected from materials and the respiratory health risks associated with a blasting environment. IST is an authorized distributor of RPB Safety providing the best respirators and supplied air breathing systems available on the market for blasters. All PPE and RPE has been designed to comply with the National Institute of Occupational Safety and Health standards (NIOSH).



BLASTING RESPIRATORS

RPB's abrasive blasting line uses the latest available respiratory protection technology. The headtops are constructed with high-density polyethylene and manufactured in accordance with NIOSH certification. The respirators are equipped with a choice of six cape options that attach at the base of the headtop with its unique button and rubber seal design, ensuring no particulates enter the operators breathing zone. With multiple size options and adjustable padding system the headtop maintains a snug customizable fit that allows the respirator to move with the operator. With the headtop and breathing tubes weight evenly distributed across the head and shoulders this alleviates aches and strains on the user and reduces fatigue. All padding is machine washable for hygiene purposes.

The replaceable air inlet fitting is located at the back of the helmet in the center providing a streamlined airflow directing air to the breath zone and preventing the lens from fogging. All respirators feature a large visor window for uncompromised downward and peripheral vision and a set of replaceable tear off lenses for increased productivity. All parts are field replaceable and can be easily changed using the Allen key that sits neatly inside the padding.



Nova 3



Nova 2000

Breathing air supply hose available in 25', 50', and 100' lengths.



AVAILABLE WITH CHOICES OF CAPES

Nova 3



Nylon Respirator Cape



Leather Respirator Cape



Blast Jacket



Extra Length Leather Respirator Cape

Nova 2000



Nylon Respirator Cape



Leather Respirator Cape



Blast Jacket



Extra Length Leather Respirator Cape

BLASTING RESPIRATORS ACCESSORIES

IST provides an extensive range of safety essentials and supplied air and respirator accessories from RPB to advance the safety of your team and increase productivity.

CLIMATE CONTROL DEVICES

The climate control devices can increase or decrease incoming air to control the temperature of supply air to the blaster for optimal comfort. Hot tube can increase incoming air by up to 20 °F /± 11 °C while Cold tube can drop the temperature by up to 32 °F/± 18 °C (evaluated at 20 cfm).

The C40 Climate Control Device combines both heating and cooling features to an even wider range – max increase is 32 °F/ ± 18 °C and max drop is 52 °F/± 29 °C – all by the press of a lever. The operator can also adjust the flow of cool and hot air to fall between this supply range.

All climate control devices are located on the fresh air tube unit, within the range of the operator.

Their performance may vary depending on the temperature of the incoming air. They all carry NIOSH approvals as part of the complete system and with the same approval numbers.

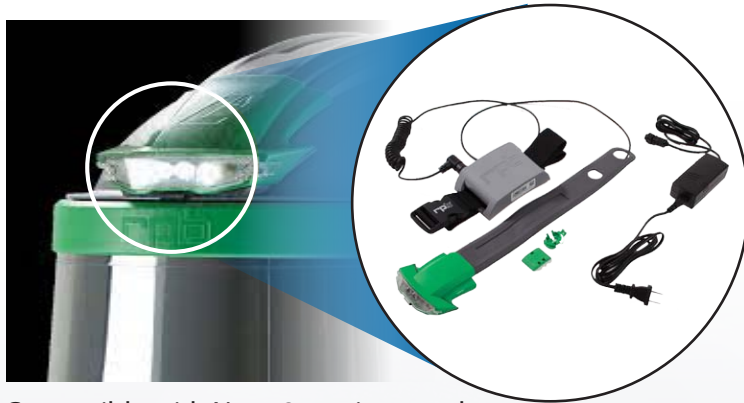

Compatible with Nova 3 respirator only

AUXILIARY HEAD LIGHT

The LED L4 Light provides up to 650 lumens of concentrated light to the operator's field of view for increased vision and safety while blasting. The L4 mounts directly to the Nova 3 and it is powered by a lightweight battery pack attached to the blaster's belt. The battery lasts for up to 6 hours with a recharge time of 3-4 hours.

INTEGRATED COMMUNICATION SYSTEM

The Nova Talk is a wireless radio communication system that fits securely inside the headtop allowing operators to communicate effortlessly with team members. The simplicity of the push to talk system ensures this does not get in the way of the operator's safety. The Nova Talk is ideal for working in remote locations, like tanks, shipyards or any other areas that are difficult to access.



AIR MONITORING, FILTRATION, AND SUPPLY

RPB's supplied air range covers air filtration and gas monitoring. These systems help protect the operator from contaminants in the air supply and notify them when there is harmful gas detected by their supplied air source. Air filtration and gas monitoring systems can help you towards achieving Grade D breathing air.

For Grade D breathing air, please refer to OSHA standard 29 CFR 1910.134 and consult an external provider for reliable air quality results. It is the end user's responsibility to comply with the standard.

BREATHING AIR LINE FILTER



2 outlet Radex - intended use of up to 1 operator and 1 gas monitor

6 outlet Radex - intended use of up to 3 operators and 1 gas monitor



The Radex is a robust and versatile airline filter with exceptional filtration capacity. It connects straight to the air line and it removes moisture, odor and particulates to 0.5 micron from the compressed air stream, providing clean, breathable air to the operator. Its replaceable filter cartridge exceeds industry filtration standards.

Standard

Optional

GAS MONITOR

The GX4 gas monitor detects when gases are present in the air supply source, alerting when carbon monoxide, oxygen and hydrogen sulphide are at levels above/below grade D breathing requirements. Its smart device and cloud integration capabilities allow you to view your air quality from any device in real time. The system stores and logs up to two years' worth of data.



OPTIONAL ACCESSORIES



Carry case for field protection



Wall Bracket



Audible and strobe light Alarm systems





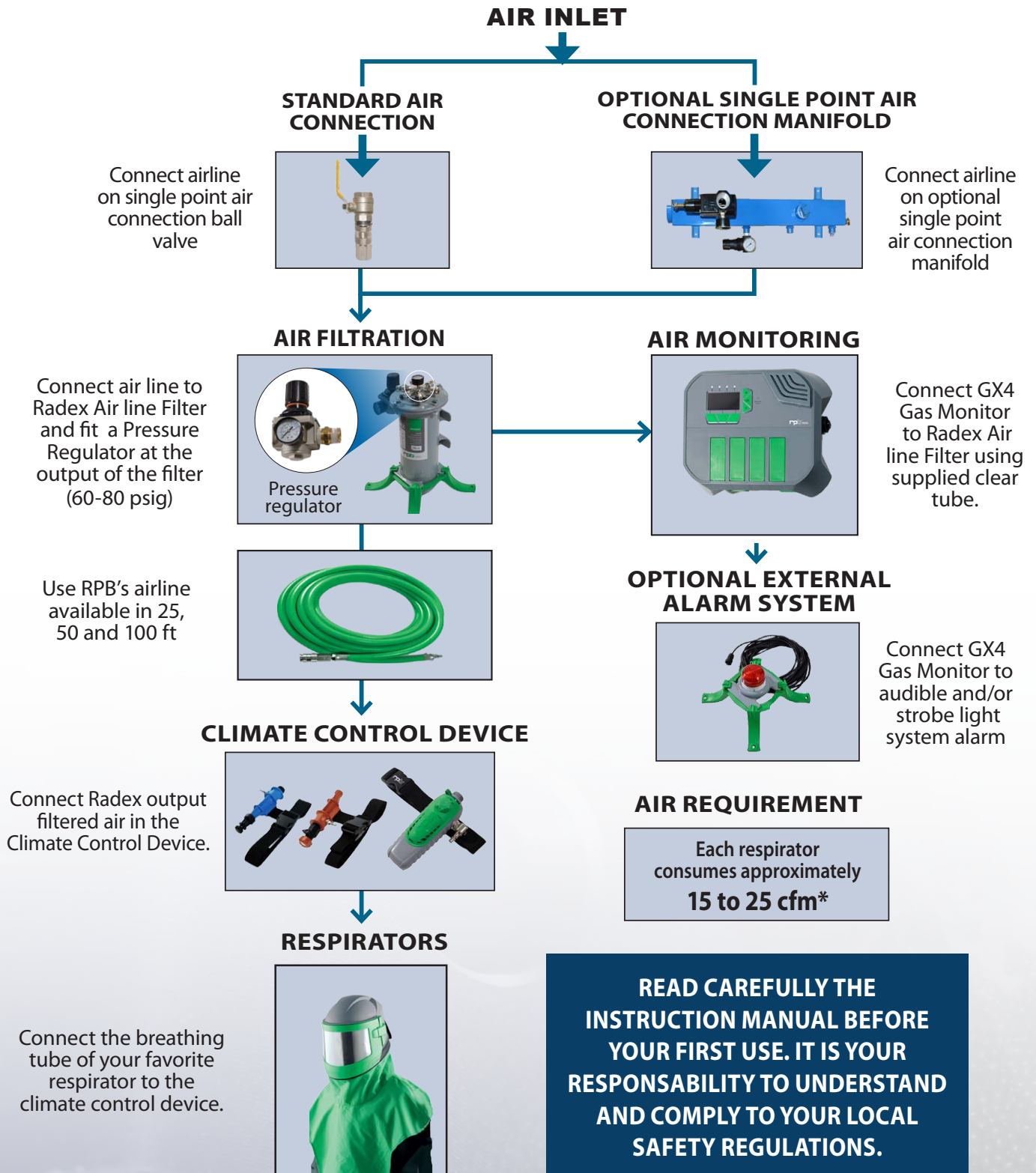



COMPLETE AIR BREATHING SYSTEM ASSEMBLY

The connection procedure below demonstrates how the RPB range helps to provide your operators with clean, safe breathing air that complies with NIOSH standards. All accessories are supplied with standard quick-connect fittings. Optional Schrader and RZ fittings are available upon request.



* Refer to Breathing Air Pressure Table in the instruction manual of your respirator. Air consumption may vary according factors like the climate, the flow device used and the total length of breathing air lines.

AIR FILTRATION AND MONITORING MAINTENANCE

EQUIPMENT	MAINTENANCE ROUTINE / FREQUENCY	SPARE PARTS
 Radex Air line Filter	<ul style="list-style-type: none"> ✓ Empty Drain Valve monthly* ✓ Replace Radex filter cartridges every 3 months or 400 working <p><i>*Not required if your Radex is equipped with Auto Drain Unit</i></p>	<div style="display: flex; justify-content: space-around;"> <div style="text-align: center;">  1 Replacement filter cartridge </div> <div style="text-align: center;">  2 Auto Drain Unit </div> </div>
 GX4 Gas Monitor	<ul style="list-style-type: none"> ✓ Pre-calibrated GX4 gas sensors have a 2-year shelf life. ✓ Sensor check on each cartridge is required monthly using Calibration Flow Regulator and Gas bottles. 	<div style="display: flex; flex-direction: column; align-items: center;"> <div style="display: flex; justify-content: space-around; width: 100%;"> <div style="text-align: center;">  3 Calibration Flow Regulator </div> <div style="text-align: center;">  4 Gas Sensors </div> </div> <div style="display: flex; justify-content: space-around; width: 100%; margin-top: 20px;"> <div style="text-align: center;">  5 Gas Bottles </div> <div style="text-align: center;">  6 Sensor Manifold Tube </div> </div> </div>

PART #	STOCK	DESCRIPTION
1	APF3100	ORIGINAL RADEX FILTER CARTRIDGE
2	04-924	AUTO DRAIN UNIT
3	08-451	GX4 CALIBRATION FLOW REGULATOR FOR CO & ZERO AIR GAS BOTTLES (INCLUDES HOSE AND FITTING)
	08-452	GX4 CALIBRATION FLOW REGULATOR FOR H ₂ S GAS BOTTLES (INCLUDES HOSE AND FITTING)
4	08-420-01	GX4 GAS SENSOR CARTRIDGE CO 10 ppm
	08-420-02	GX4 GAS SENSOR CARTRIDGE CO 5 ppm
	08-420-03	GX4 GAS SENSOR CARTRIDGE H ₂ S 10 ppm
	08-420-04	GX4 GAS SENSOR CARTRIDGE OXYGEN 19.5-23 %
5	08-460	GX4 ZERO AIR (HAZMAT) FOR ZERO AIR AND OXYGEN SENSORS
	08-462	GX4 ZERO AIR (HAZMAT) FOR USE WITH H ₂ S 20 ppm CARTRIDGES
	08-461	GX4 CO 20 ppm (HAZMAT) FOR USE WITH BOTH 10 ppm AND 5 ppm CARTRIDGES
6	08-422	SENSOR MANIFOLD TUBE
	*NV2028	25' BREATHING AIR SUPPLY HOSE C/W CONNECTORS
	*NV2029	50' BREATHING AIR SUPPLY HOSE C/W CONNECTORS
	*NV2027	100' BREATHING AIR SUPPLY HOSE C/W CONNECTORS

*Air lines can be joined together up to 300' max overall length

FOR COMPLETE PARTS LISTING, DOWNLOAD RPB'S FULL PRODUCT CATALOG

BLAST SUITS

IST BLAST SUITS

IST offers a range of superior quality blast suits designed to produce the ultimate protection for workers, while increasing the comfort and productivity.

Available in ultralight nylon or durable leather, these suits are designed with only rugged materials and a combination of wear-resistant fabrics and porous cotton to keep the blaster dry and protected at all time.

The combinations include fastening straps to each cuff and to the bottom of the leg. A pair of heavy-duty leather gloves completes the set.



Ultralight Nylon



Heavy-Duty Leather

RPB BLAST SUIT

The RPB Blast Suit is a lightweight suit that provides protection against abrasive rebound.

It is made from heavy duty nylon to provide protection to the front of your body and arms, with a breathable cotton back to help keep you cool.

Features :

- ✓ Triple stitching for durability
- ✓ Optional knee pads
- ✓ Available in 7 sizes:
S, M, L, XL, XXL, XXXL, XXXXL
- ✓ Robust nylon zipper with protective cover
- ✓ Elasticated waist for a comfortable fit
- ✓ Elasticated wrists and adjustable ankle cuffs
- ✓ Interior pocket



Leather Gloves

ISTBLAST LIMITED WARRANTY

ISTblast warrants all equipment led in this manual which is manufactured by ISTblast and bearing its name, to be free from defects in material and workmanship on the date of sale by an authorized ISTblast distributor to the original purchaser for use. Notwithstanding any special, extended or limited warranty published by ISTblast will, for a period of TWELVE (12) months from the date of sale, repair or replace any part of the equipment determined by ISTblast to be defective. This warranty applies only when the equipment is installed, operated and maintained in accordance with ISTblast's written recommendations.

This warranty does not cover, and ISTblast shall not be liable for general wear and tear, or any malfunction, damage or wear caused by faulty installation, misapplication, abrasion, corrosion, inadequate or improper maintenance, negligence, accident, tampering, or substitution of non-ISTblast component parts. Nor shall ISTblast be liable for malfunction, damage or wear caused by the incompatibility with ISTblast equipment with structures, accessories, equipment or materials not supplied by ISTblast, or the improper design, manufacture, installation, operation or maintenance of structures, accessories, equipment or materials not supplied by ISTblast.

This warranty is conditioned upon the prepaid return of the equipment claimed to be defective to an authorized ISTblast distributor for verification of the claimed defect. If the claimed defect is verified, ISTblast will repair or replace free of charge any defective parts. The equipment will be returned to the original purchaser, transportation prepaid. If the inspection of the equipment does not disclose any defect in material or workmanship, repairs will be made at a reasonable charge, which charges may include the costs of parts, labor, and transportation.

THIS WARRANTY IS EXCLUSIVE, AND IS IN LIEU OF ANY OTHER WARRANTIES, EXPRESSED OR IMPLIED, INCLUDING BUT NOT LIMITED TO WARRANTY OF MERCHANTABILITY OR WARRANTY OF FITNESS FOR A PARTICULAR PURPOSE.

ISTblast's sole obligation and the buyer's sole remedy for any breach of warranty shall be as set forth above. The buyer agrees that no other remedy (including, but not limited to, incidental or consequential damages for lost profits, lost sales, injury to person or property, or any other incidental or consequential loss) shall be available. Any action for breach of warranty must be brought forward within one (1) year of the date of sale.

ISTblast MAKES NO WARRANTY, AND DISCLAIMS ALL IMPLIED WARRANTIES OF MERCHANTABILITY AND FITNESS FOR A PARTICULAR PURPOSE, IN CONNECTION WITH ACCESSORIES, EQUIPMENT, MATERIALS OR COMPONENTS SOLD BUT NOT MANUFACTURED BY ISTblast. These items sold, but not manufactured by ISTblast (such as electric motors, switches, hose, etc.), are subject to the warranty, if any, of their manufacturer. ISTblast will provide the purchaser with reasonable assistance in making any claim for breach of these warranties.

LIMITATION OF LIABILITY

In no event will ISTblast be liable for indirect, incidental, special or consequential damages resulting from ISTblast supplying equipment hereunder, or the furnishing, performance, or use of any products or other goods sold hereto, whether due to a breach of contract, breach of warranty, the negligence of ISTblast, or otherwise.

The following items are not covered under the ISTblast warranty policy:

- Parts or chassis replacement due to normal wears.
- Defective material or workmanship is not considered normal wear.

Report all accidents or "near misses" which involve ISTblast products to our service department :

1 877 629-8202



ABOUT THE COMPANY

WHO WE ARE

IST is a leading industrial manufacturer of standard and custom engineered equipment for the surface treatment industry and the solvent recycling industry.

MISSION

IST is dedicated to being an innovative and trusted supplier in the conception, fabrication and distribution of surface treatment equipment and recycling equipment.

The success of our mission relies on the following core values :

Innovation - Integrity - Quality

The products, technologies and industry expertise of IST are used in a wide range of manufacturing and industrial applications, including but not limited to :

- General Manufacturing
- Industrial Equipment
- Metal forming
- Aerospace and Aviation
- Rail and Transit
- Marine
- Automotive
- Petroleum
- Flexography (labelling) & Lithography
- Wood finishing
- Power & Energy
- Pharmaceutical

