



ABRASIVE BLAST ROOM MSW1200 PNEUMATIC RECOVERY SYSTEM



MSW1200 Pneumatic Floor Recovery System is an efficient and inexpensive solution for recovering used abrasive with minimal effort from the operator. This system is equipped with a standard impeller dust collector (DCM230), it can handle all major light-to-heavy abrasives available in the market and it offers various floor hoppers layouts.



TABLE OF CONTENTS

	Page
TABLE OF CONTENTS.....	2
PNEUMATIC RECOVERY SYSTEM - MSW1200	3
KEY FEATURES.....	4
KEY FEATURES (CONT'D).....	5
INSIDE THE ROOM	6
MEDIA RECOVERY SYSTEM.....	7
R.O.I. (RETURN ON INVESTMENT)	7
HOW IT WORKS.....	8
RECOVERY FLOORS	9
3-AXIS BLAST MEDIA / BLAST BOOTH LIFTS	10
SECURITY EQUIPMENT.....	11
CHOICE OF PRESSURE VESSELS.....	11
AIR & ABRASIVE CONSUMPTION	12
RECOVERABLE BLASTING MEDIA	12
BLAST ROOM DUST COLLECTORS	13
ABRASIVE BLAST ROOM SYSTEMS.....	14
INFORMATION / TECHNICAL ASSISTANCE	15
BENEFITS OF OWNING AN ISTBLAST ABRASIVE BLAST ROOM :	16



PNEUMATIC RECOVERY SYSTEM - MSW1200

HOW IT WORKS

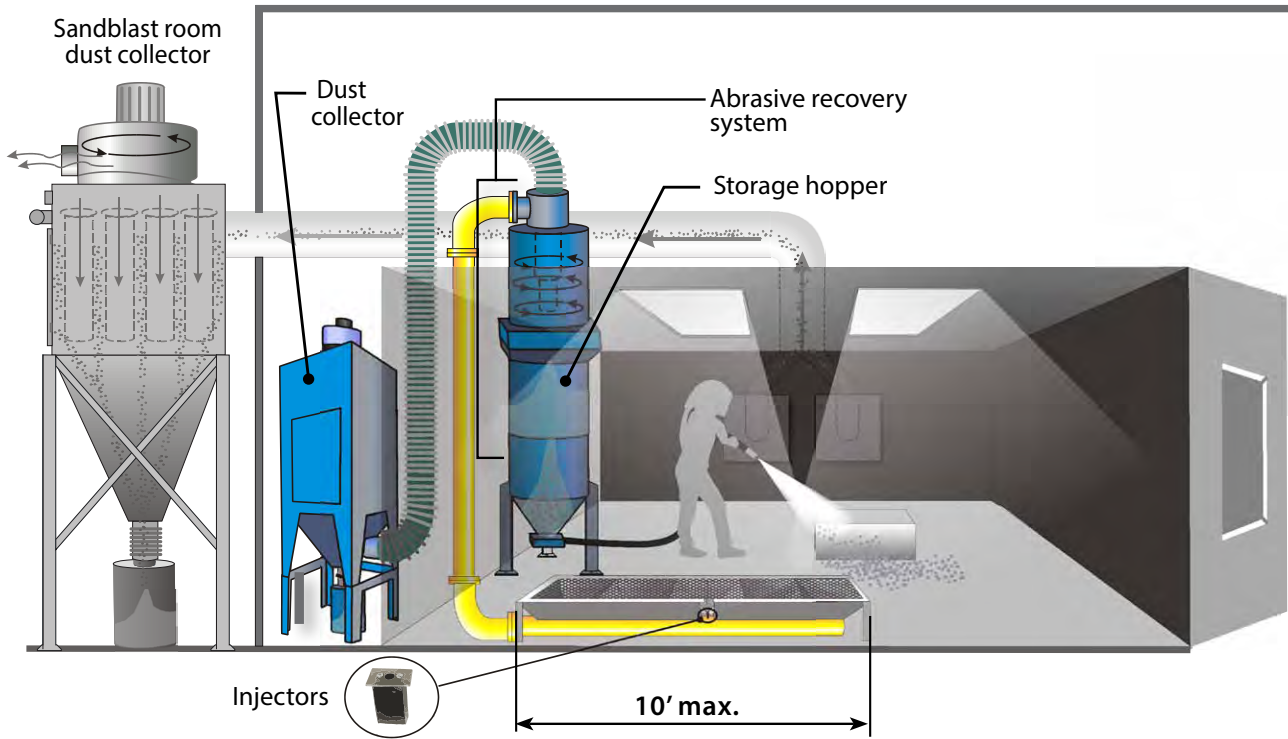

KEY POINTS

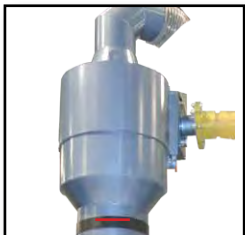

100% adjustable
cyclonic separator



Dust collector
DCM230



Pneumatic recovery
system with floor
hoppers



Recovery system
capacity



Light abrasive only

RECOVERY HOPPERS LAYOUTS AVAILABLE

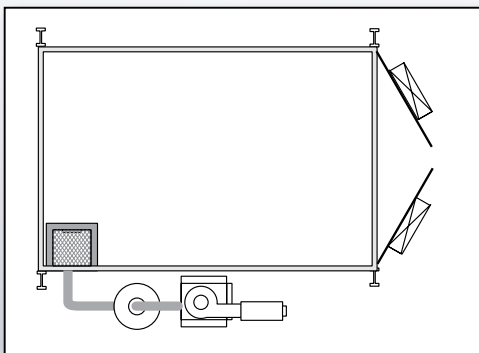

Corner shoot / Shoveling

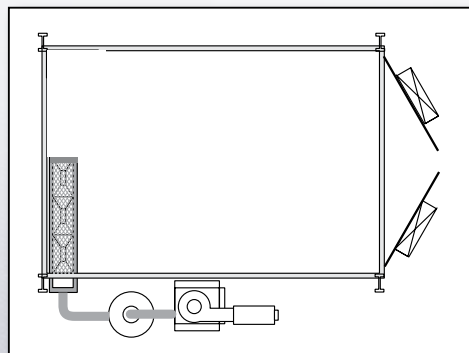

Single in ground pneumatic through





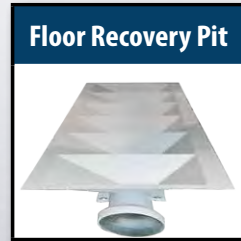
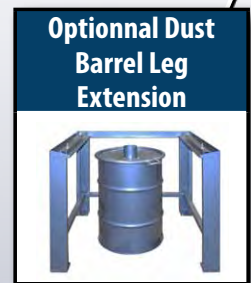
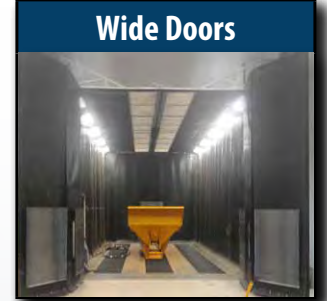
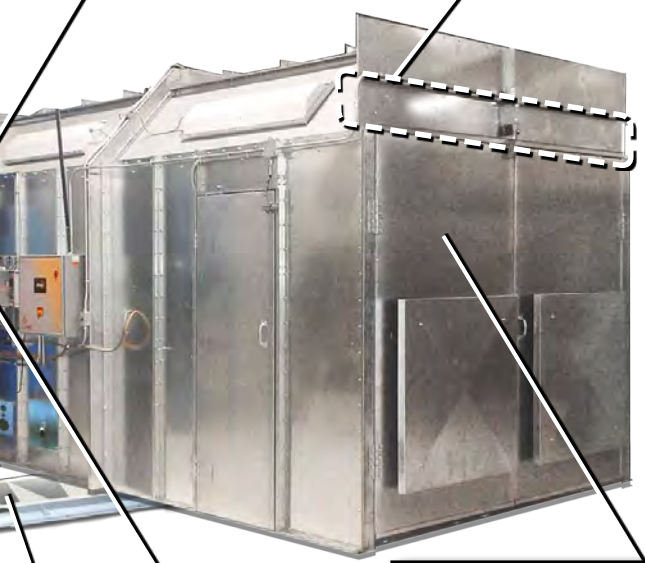
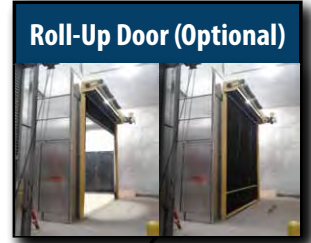
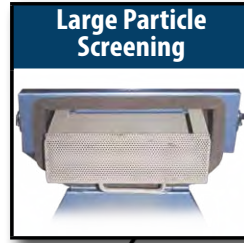











KEY FEATURES





KEY FEATURES (CONT'D)

VISUAL	DESCRIPTION
	Standard blower 6 hp turbine engine providing high filtration efficiency to suck and extract fine particles and dust from abrasive residues produced during blasting
	Motorized dust collector DCM30 specially designed for our blast room pneumatic recovery system. DCM230 is equipped with manual (or optional automatic) shaker for dislodging dust agglomerated on surface of filter bags and requires minimal supervision and maintenance from operator.
	Roll-Up Door (Optional) Durable roll-up rubber doors designed to withstand harsh environment and requiring minimal maintenance.
	Wide doors opening and low footprint door system to enter large parts into the room.
	Storage hopper provides long hours of blasting autonomy.
	Large Particle Screening that contains large particles before they clog the system.
	Optional Dust Barrel with Leg Extension and 55 gal. barrel dust collecting barrel to raise up the dust collector accordingly.
	Pressure vessel in a various selection can supply up to 2 operators.
	Media Transport Duct with sturdy urethane ducting to convey residual abrasive up to the media reclaimer.
	Floor Recovery Pit all pneumatic, low maintenance floor recovery pit where residual abrasive is swept or shovel after blasting.
	Air Fed Hood provides comfort and respiratory protection for long hours of blasting.
	Hot/Cold Tubes temperature control warm up / cool down breathable air supplied for increase comfort.
	4-stage purification system provides grade « D » air and detects carbone monoxide.
	Radex Air Purifier removes 98% of particles down to 0.5 micron size.



INSIDE THE ROOM

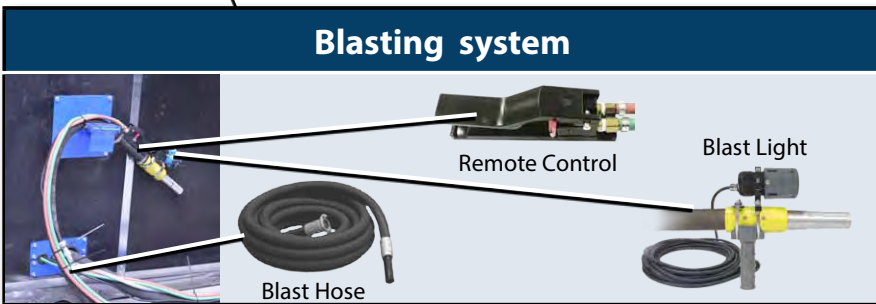
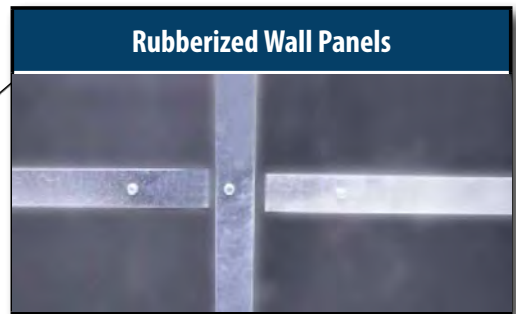
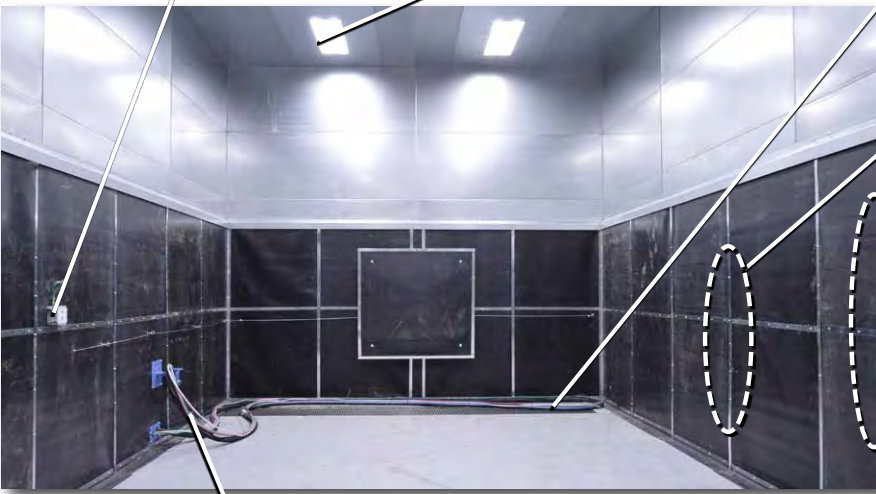
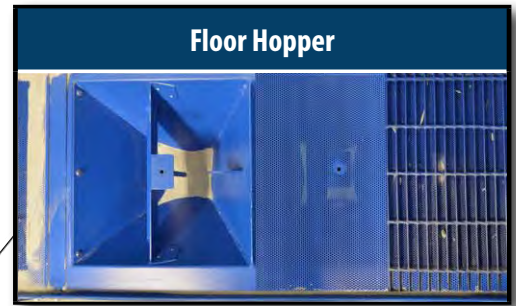

VISUAL	DESCRIPTION
	Depress switch allows operator to fill the pressure vessel without leaving the room.
	High efficiency LED lighting system producing 65% more lumens and consuming 90% less energy.
	Pneumatic duct conveys abrasives residues to the media reclaimer.
	Tightly sealed rubberized panels protecting the inside of the blast room.
	Audible Alarm on wall and Emergency Exit located above the door.

VISUAL	DESCRIPTION
	Durable 50' blast hose.
	Pneumatic remote control at the nozzle to operate blasting.
	LED auxiliary lighting system for better visibility.



MEDIA RECOVERY SYSTEM

All our abrasive blast rooms are delivered with a media recovery system. Following the blasting process, residual abrasives accumulated can be vacuumed, swept or shoveled into the recover pit.

Collected used abrasive is conveyed to an adjustable abrasive separator to be cleaned and recycled. Reusable abrasive is then returned to the pressure vessel to be used again, while dust and fine particles are evacuated to the filtration system.

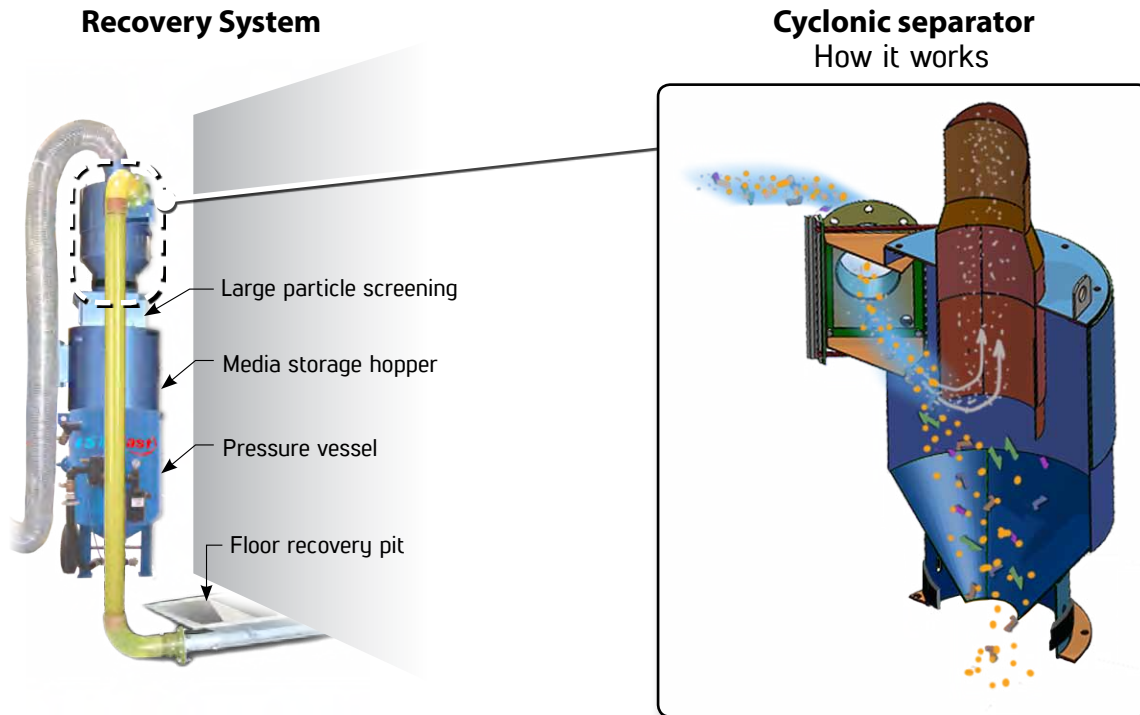

R.O.I. (RETURN ON INVESTMENT)

Recycling abrasives enables the user to achieve considerable savings in abrasives consumption while protecting the environment from harmful sandblasting dust.

Steel grit abrasives can be recycled and used up to 100 times compared to only one use with non-recyclable media. The non-recyclable sandblasting abrasives are low in cost, but they can only be used for one sandblasting cycle. Because of their fragile molecular structure, they deteriorate quickly while generating harmful sandblasting dust and significantly reduce the visibility of the operators.

Recyclable Abrasives vs Non-Recyclable Abrasives Example

DESCRIPTION	SILICA SAND	STEEL GRIT	SAVINGS \$/ DAY
Pounds per day	4 000	4 000	4 000
Abrasive (price/lb) x % breakdown	(\$0.12 x 4000) x 100 % = \$ 480	(\$0.75 x 4000) x 5 % = \$ 150	\$ 330.00
Cleaning	4h x \$ 25	2 h x \$ 25	\$ 50.00
Abrasive disposal cost	\$8 / day	\$0.40 / day	\$ 7.60
Additional electrical cost (600 V - 8 A)	\$0.00 / day	\$6.00 / day	- \$ 6.00

Total savings per day : \$ 381.60



HOW IT WORKS

The operation of a pneumatic recovery system is very simple. Following the blasting process, the residual abrasives accumulated on the floor can be manually or mechanically swept into the recovery pit.

The pneumatic recovery system collects and conveys the used abrasive to the recycler to be cleaned and recycled. The clean abrasive is then deposited in the pressure vessel to be used again for disposal blasting process, while the dust is conveyed to the filtration system.

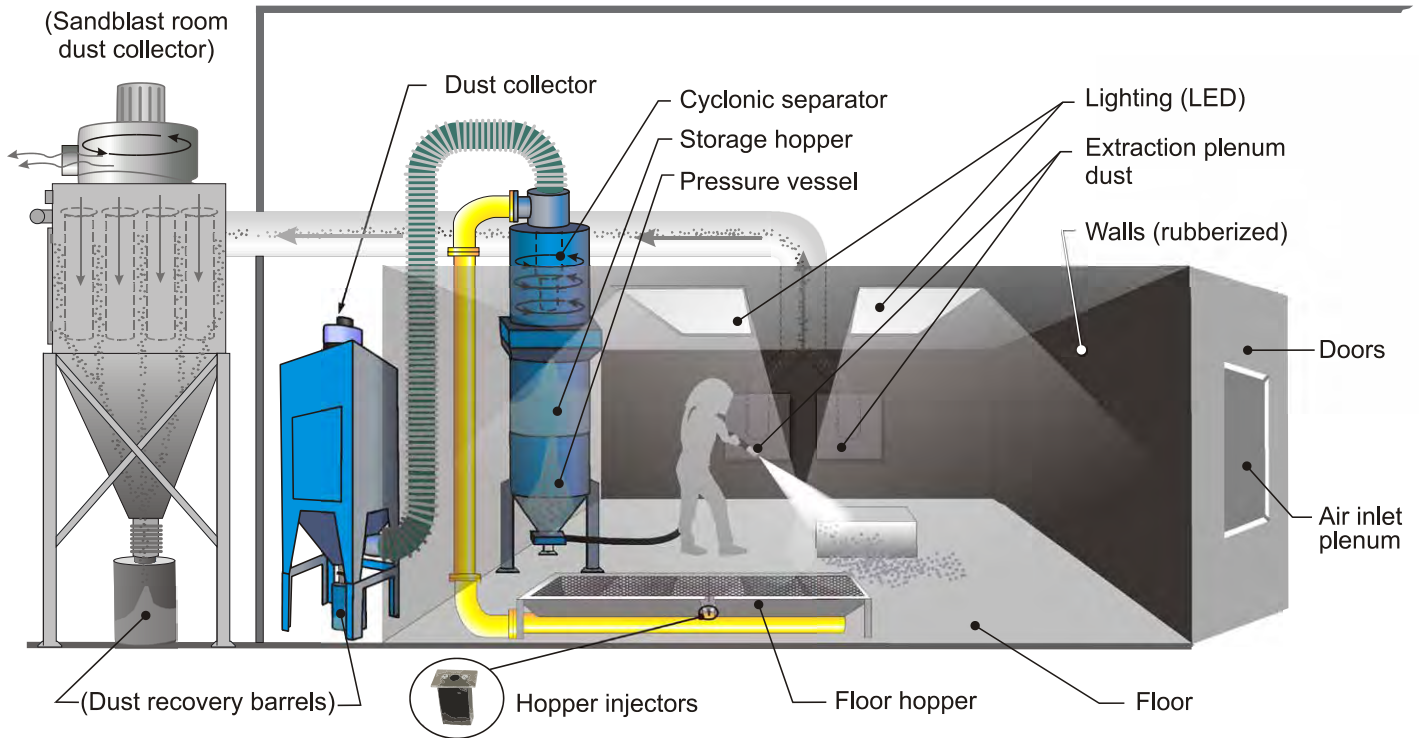

RECOVERY HOPPERS LAYOUTS AVAILABLE

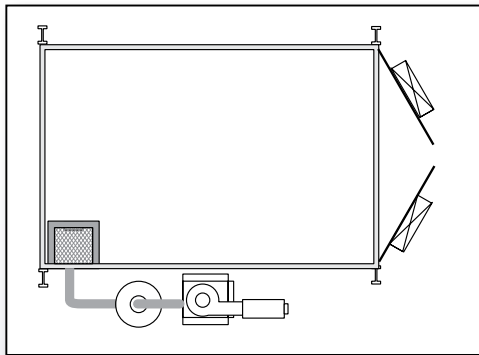

Corner shoot / Shoveling

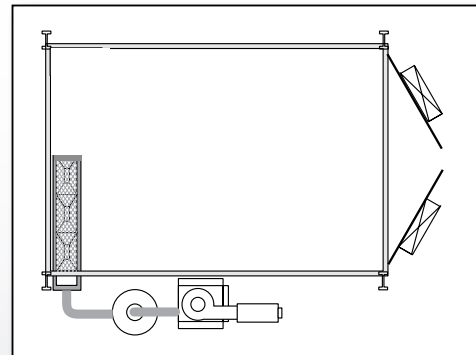

Single in ground pneumatic through

RECYCLABLE ABRASIVES			
Type of abrasive	Hardness	Durability	Density
Glass Beads	50-60 Rc (5-7 Mohs)	5-8 cycles	2.6 g/cc
Stainless Steel Shot	20 Rc (work hardens to 60 Rc)	3500-4500 cycles	7.0 g/cc
Plastic Media	3-4 Mohs	4-6 cycles	1.5 g/cc
Aluminium oxide	50-65 Rc (5-7 Mohs)	25-40 cycles	3.7 g/cc
Ultra Soft Shot	3-3.5 Mohs	6000-7000 cycles	7.4 g/cc



RECOVERY FLOORS

ISTblast offers recovery floors to meet almost any budget and production requirements. Mounted on the surface or excavated, pit dimensions can vary from 4 feet in length for compact installations, to more than 40 feet for high output industrial facilities. The configurations are practically infinite.

The recovery system is determined by the type of abrasive being used, (screw conveyor vs. pneumatic), your production requirements and budget. Full recovery hopper are slightly costly but provide larger recycling of abrasive. Partial recovery and corner boxes require the operator to sweep the abrasive to the reclaim system. If your parts are to be handled by forklifts, the recovery system must be designed to accommodate the extra weight of a forklift.

ISTblast's partial floors are available in sweep-chute or a long pit designs. The sweep-chute design is recommended if you require a very small working area as the configuration can retrieve media from the corner of the room. .

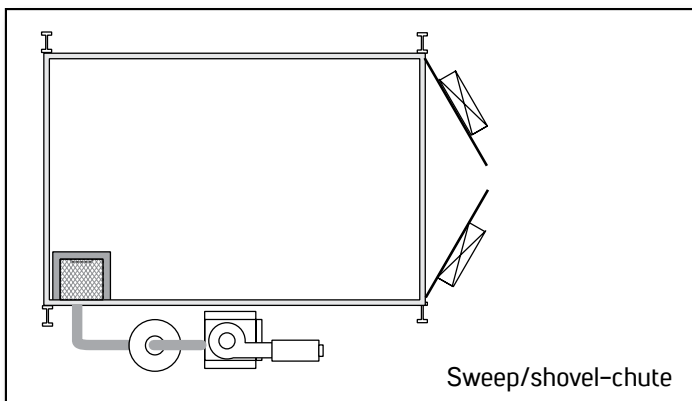

The sweep-chute recovery systems provide the most economical method for recycling media through the media recuperation system.

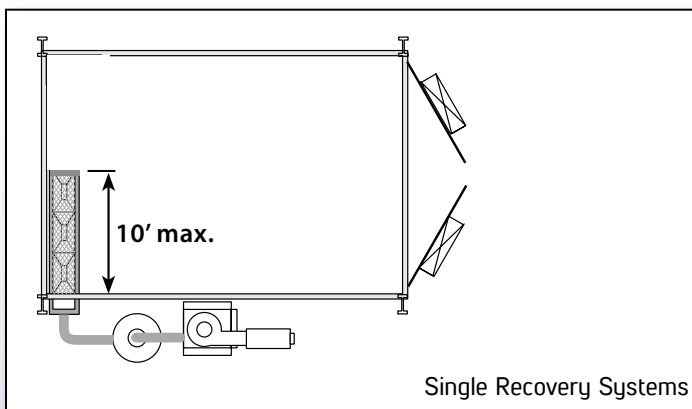

The media recovery hopper system contains a single pit of 10' max. usually located at the back of the blast room. This is typical design is common to allow for low to medium production levels.



3-AXIS BLAST MEDIA / BLAST BOOTH LIFTS

BL lifts are designed to withstand the harsh environment of grit, sand, and shot blast booths. Manufactured with sealed components and lift mast along with heavy duty components, the lifts can replace ladders providing increased safety and productivity. This efficient design can be used to reach heights of up to 27 feet.



- Customizable raised-platform heights up to 20 feet
- Retracted dimension 4'-0"
- Extended dimension 9'-0"
- Operator platform capacity 500 lb
- Sealed mast construction
- Pneumatic/hydraulic power unit
- Platform 48" wide x 30" deep
- Operator controls on front rail of platform
- Hand controls for Y-Axis, Z-Axis, and emergency stop
- Foot control for X-Axis
- Base control to raise and lower platform
- Lift equipped with Filter/Regulator/Lubricator
- Self-closing/self latching entry gates
- 1 and 2 axis models available
- Lift requires a clean, dry air supply of 80 scfm @ 100 psi with a 40° F dew point.

Travel Speeds :

- X-Axis variable up to 40 fpm
- Y-Axis 15 fpm
- Z-Axis 15 fpm

Extended reach model :

- Retracted dimension 4'-6"
- Extended dimension: 13'-4"
- Operator platform capacity: 400 lb

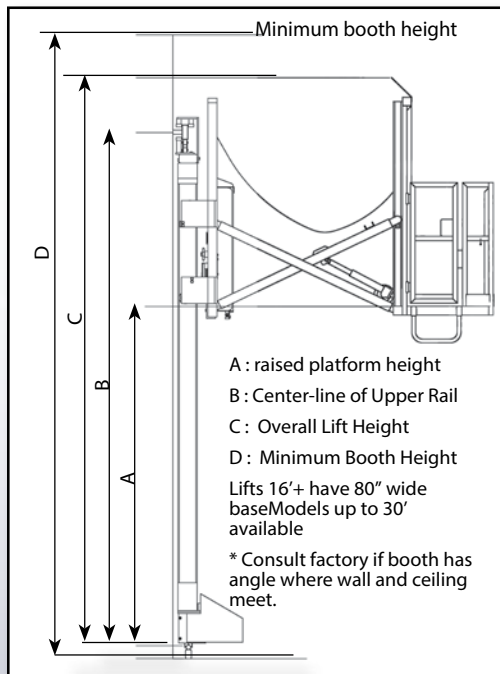

Fully Extended Dimension 9' (Y-Axis) Extended Reach Model 13'-4" Fully Extended (Y-Axis)				
Model	A	B	C	D
BL-89	8'- 0"	12'- 11¼"	14'- 6"	15'
BL-99	9'- 0"	13'- 11¼"	15'- 6"	16'
BL-109	10'- 0"	14'- 11¼"	16'- 6"	17'
BL-119	11'- 0"	15'- 11¼"	17'- 6"	18'
BL-129	12'- 0"	16'- 11¼"	18'- 6"	19'
BL-139	13'- 0"	17'- 11¼"	19'- 6"	20'
BL-149	14'- 0"	18'- 11¼"	20'- 6"	21'
BL-159	15'- 0"	19'- 11¼"	21'- 6"	22'
BL-169	16'- 0"	20'- 11¼"	22'- 6"	23'
BL-179	17'- 0"	21'- 11¼"	23'- 6"	24'
BL-189	18'- 0"	22'- 11¼"	24'- 6"	25'
BL-199	19'- 0"	23'- 11¼"	25'- 6"	26'
BL-209	20'- 0"	24'- 11¼"	26'- 6"	27'



CHOICE OF PRESSURE VESSELS

We offer different options and configurations of pressure vessels to accommodate your needs and maximize your productivity.



PPB 646



PPB 1046
(up to 2 operators)

Specifications	PPB 646	PPB 1046
Loading capacity (A.S.M.E.)	6.5 cu.ft.	10 cu.ft.
Tank diameter	24"	24"
Media loading (abrasive)	600 lb.	1,000 lb.
Lenght x height x width	32" x 50" x 35"	32" x 66" x 35"
Weight	350 lb.	575 lb.
Number or operators	1	1 or 2

CONFIGURATION OPTIONS	
Pressure hold system	Pressure release system
<ul style="list-style-type: none"> ✓ No depressurization when blasting operations stop ✓ Reduces air consumption ✓ Convenient for frequent start/stop operations ✓ Even abrasive flow when starting operations 	<ul style="list-style-type: none"> ✓ Pressure vessel automatically depressurizes when blasting operation stop ✓ Automatic filling of the pressure vessel, without any intervention ✓ Less wear-and-tear for the abrasive metering valve ✓ Simplified and cheaper maintenance
Double Control system	
<ul style="list-style-type: none"> ✓ Combined system offers the advantages of both configurations without the disadvantages. 	

UPGRADE KIT



UPGRADE TO MAXBLAST FOR MORE POWER AND BLASTING SURFACE



Coupling



Automatic Air Valve

Maxblast upgrade kit includes an automatic air valve and fitting that allows you to install a 1½" blast hose which increases air pressure at the nozzle, reduces pressure losses and increases operator productivity.

BENEFITS OF MAXBLAST

- Reduction of pressure losses from 24% to 27%
- Increased in productivity (blasting time) from 36% to 40%

SECURITY EQUIPMENT

IST provides a 4-stage filtration system to provide breathable air to the operator's hood, eliminating air contaminants such as oil vapors, hydrogen gases, rust and other potentially hazardous contaminants to provide pure compressed air of respirable quality.

This system is equipped with an air supply detector and a carbon monoxide detector which continuously monitors and samples the air supplied in accordance with OSHA standards.



LED blast light



AIR & ABRASIVE CONSUMPTION

PRESSURE

Opening	psi ¹	30	40	50	60	70	80	90	100°
1/8"	cfm ²	8	10	11	13	15	17	19	20
	lb/h ³	55	69	84	97	110	127	140	154
3/16"	cfm ²	18	22	26	30	33	38	41	45
	lb/h ³	130	160	170	192	220	243	268	297
1/4"	cfm ²	34	41	47	54	61	68	74	81
	lb/h ³	219	276	302	351	398	460	504	556
5/16"	cfm ²	53	65	77	89	101	113	126	137
	lb/h ³	410	495	526	601	680	756	832	910
3/8"	cfm ²	76	91	108	126	143	161	173	196
	lb/h ³	570	710	750	860	970	1080	1184	1296
7/16"	cfm ²	100	124	147	170	194	217	240	254
	lb/h ³	770	840	1008	1160	1320	1476	1630	1782
1/2"	cfm ²	137	165	195	224	252	280	309	338
	lb/h ³	1015	1230	1305	1500	1700	1890	2088	2277
5/8"	cfm ²	212	260	308	356	404	452	504	548
	lb/h ³	1325	1600	1875	2140	2422	2690	2973	3250

RECOVERABLE BLASTING MEDIA

SPHERICAL SHAPED MEDIA

Ceramic Beads	Glass Beads	Stainless Shot	Steel Shot

ANGULAR SHAPED MEDIA

Aluminium Oxide	Ceramic Grit	Crushed Glass	Garnet	Plastic Media	Silicon Carbide	Stainless Grit	Steel Grit	Walnut Shells

MEDIA GUIDE

	Glass Beads	Ceramic Grit	Stainless Cut Wire	Steel Shot	Steel Gri	Aluminium Oxide	Silicon Carbide	Garnet	Crushed Glass	Plastic Media	Walnut Shells
Finishing	YES	YES	YES	YES	YES	YES	YES	YES	YES	NO	NO
Cleaning/Removal	YES	YES	YES	YES	YES	YES	YES	YES	YES	YES	YES
Peening	YES	YES	YES	YES	NO	NO	NO	NO	NO	NO	NO
Surface Profiling (Etch)	NO	NO	YES	NO	YES	YES	YES	YES	YES	YES	YES
Working Speed	MED.	MED.	MED.	MED.	MED.-HIGH	HIGH	VERY HIGH	HIGH	HIGH	MED.-HIGH	LOW-HIGH
Recyclability	HIGH-LOW	HIGH	HIGH	VERY HIGH	VERY HIGH	MED.-HIGH	MED.-LOW	MED.	MED.-LOW	MED.	LOW
Probability of Metal Removal	VERY LOW	VERY LOW	VERY LOW	VERY LOW	MED.	MED.-HIGH	MED.-HIGH	MED.	LOW-MED.	VERY LOW	VERY LOW
Hardness, MOH Scale (Rockwell RC)	5.5	7 (57-63)	6-7.5 (35-55)	6-7.5 (35-55)	8-9 (40-66)	8-9	9	8	5.5	3-4	1-4.5
Bulk Density (lb/cu.ft.)	100	150	280	280	230	125	95	130	100	45-60	40-80
Mesh Size	30-440	8-46	20-62	8-200	10-325	12-325	36-220	16-325	30-400	12-80	MANY
Typical Blast Pressure	20-55	20-90	20-90	20-90	20-90	20-90	20-90	30-80	20-50	20-60	10-40
Shapes : ● or ▲	●	●	●	●	▲	▲	▲	▲	▲	● or ▲	▲

* Above information is intended as a general reference guide



BLAST ROOM DUST COLLECTORS

IST offers a wide selection of fully equipped blast room dust collectors with up to 50,000 cfm in capacity.

Our vertical design and pulsation system provide a more efficient means to remove dust from cartridges, eliminating uneven dust accumulation associated with horizontally mounted cartridges.



DCM 3,000 to 50,000



Simple and safe cartridge replacement system requiring no tools.



Automatic Pulse Cartridge Cleaner. A light illuminates to indicate when the cartridges must be replaced.



Optional screw conveyor to collect dust inside the building

DIFFERENT TYPES OF DUST EXTRACTION DUCTINGS

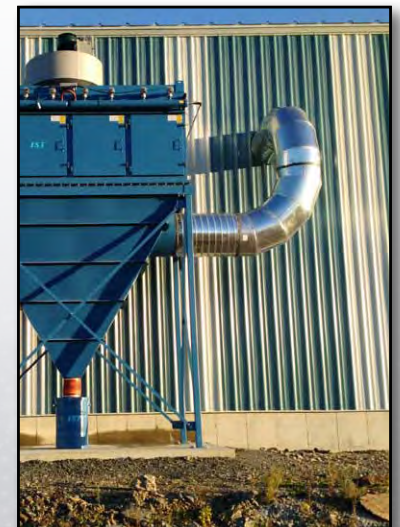



ABRASIVE BLAST ROOM SYSTEMS

We offer a wide range of customized solutions to meet any need.



Full floor

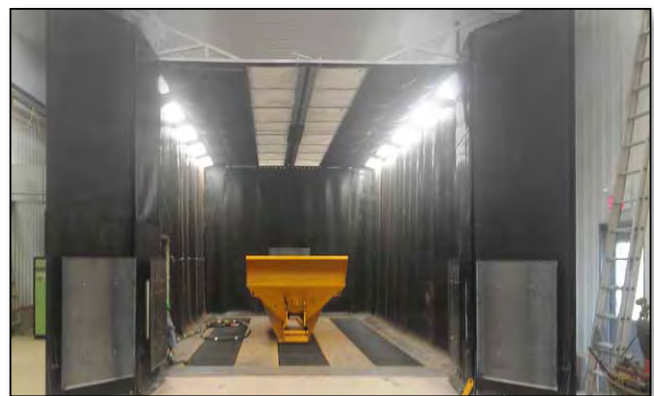

Triple or dual recovery floor



Partial recovery floor

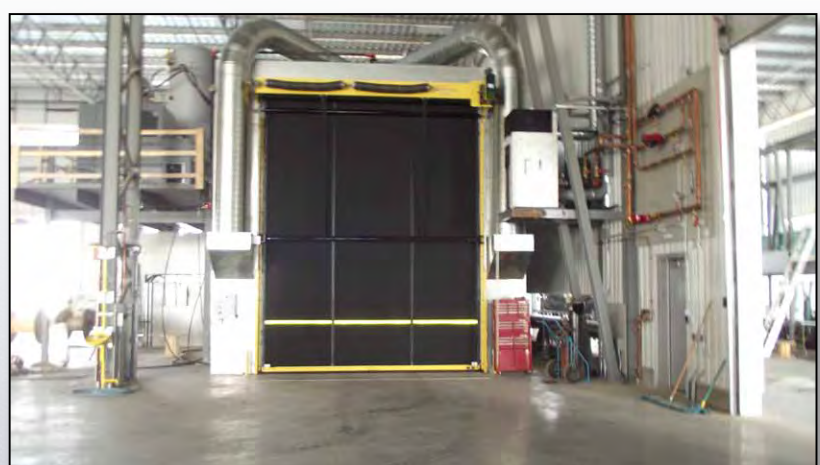

Roll up doors



INFORMATION / TECHNICAL ASSISTANCE

ISTblast is a registered trademark of:

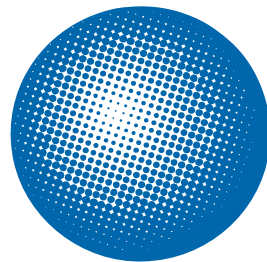

**International
Surface
Technologies**

istsurface.com

For more information, pricing or technical support, contact your local IST distributor or call / fax to our Consumer Information

TEL.: 1 877 629-8202 & 450 963-4400 FAX : 450 963-5122

Or visit us at:
istsurface.com

Benefits of Owning an ISTblast Abrasive Blast Room :

- Significant cost savings since abrasives can be collected, sorted and recycled
- Increase in productivity since you can blast 24/7 indoors

Industrial applications

- General Manufacturing
- Industrial Equipment
- Metal forming
- Aerospace and Aviation
- Rail and Transit
- Marine
- Automotive
- Petroleum

INNOVATIVE AND LEADING TECHNOLOGY

Founded in 1978, International Surface Technologies (IST) is a North American leader in abrasive blast rooms, sandblasting cabinets and portable sandblasting equipment. The company's success is based on its unwavering commitment to technical excellence, world-class manufacturing and unparalleled customer service.

Working closely with qualified distributors and abrasive users, IST offers systems, products and technologies that set the quality standard in a wide range of surface treatment applications. IST provides equipment for a wide range of industries for preparing surfaces to receive paint applications or for strengthening surface profiles to resist wear and tear.

IST's ongoing investment in abrasive blasting equipment and research and development will continue to provide innovative solutions to a diverse global market. Call today for product information, to request a demonstration or for a free quote.

