



SUCTION SANDBLASTING CABINETS **ECONOBLAST® SERIES**



The Econoblast® Series is a very cost-effective option for light-duty applications such as light cleaning and surface preparation. These suction-type cabinets are suitable for small shops and occasional users. They offer equivalent reliability and performance as an industrial equipment at a fraction of the price.

Our cabinets use simple, pneumatic controls for greater reliability when used in harsh industrial environment compared to electric controls. Built with robust 14-gauge steel construction, Econoblast® Series Cabinets are available in various sizes and configurations to address your applications.

Econoblast® Cabinets come equipped with a handy sandblasting gun operated with a trigger and offers great visibility inside the cabinet, thanks to its high-efficiency LED lighting system and its powerful dust collecting system.

MARKETS

- General Manufacturing
- Aerospace & Aviation
- Mechanical Workshop
- Automotive & Bodyshop
- Machine & Repair Shop
- Transit & Public Transport
- Metal Forming & Finishing
- Artworks
- Machined Parts & Molding

COMMON APPLICATIONS

- Light Duty Cleaning
- Metal finishing and surface preparation
- Stripping, trimming and restoring metal parts and surfaces
- Etching artwork into glass, plastics and other materials
- Removing burrs, flashings and imperfections from castings or molded parts
- Removing release agents from molds and restoring castings
- 2-Year IST Industrial Warranty



HOW IT WORKS

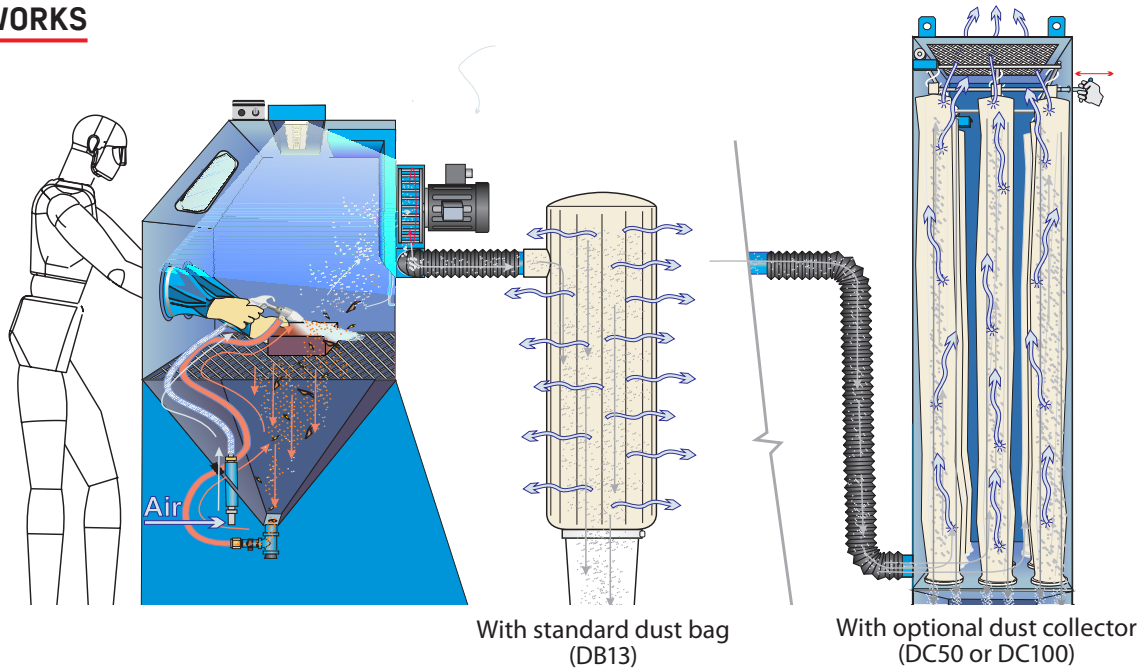

STANDARD FEATURES





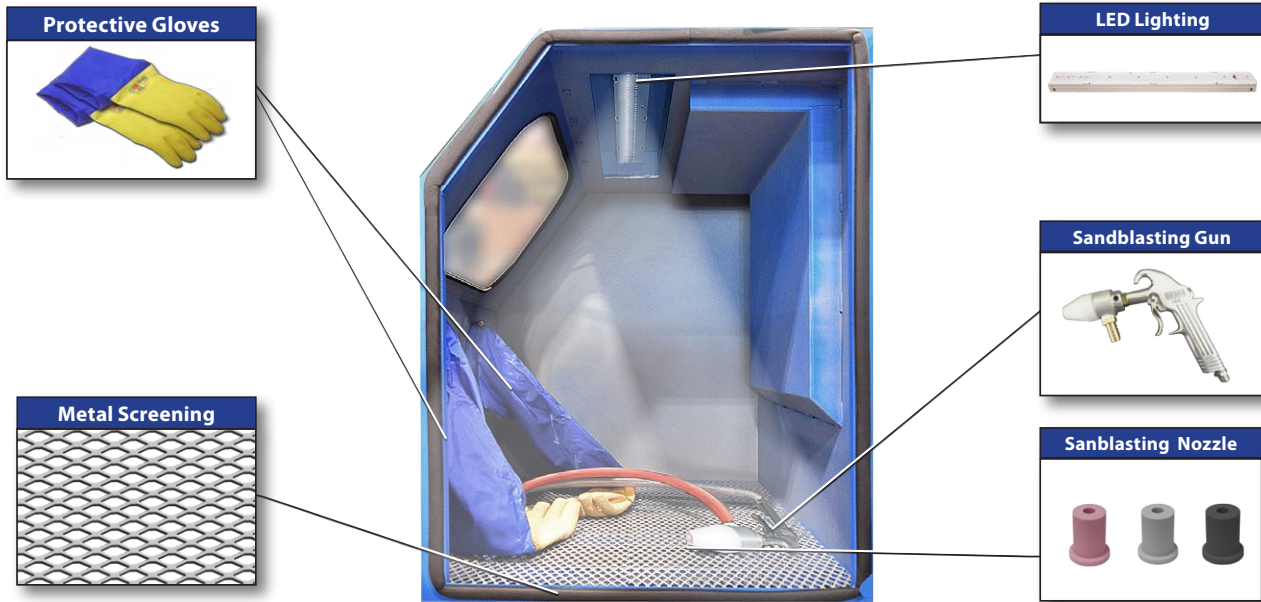

VISUAL	DESCRIPTION
	DB13 is a 13 sq. ft. filtration bag system with dust collecting bucket.
	Rigid door with self-adjusting door latch stands up to abrasives and seals tightly against dust as door gasket ages.
	Wide laminated glass security window (14" x 22") offering great visibility inside the cabinet with interchangeable plastic liners.

VISUAL	DESCRIPTION
	Complies with OSHA requirements.
	Certified QPS in Canada and in the U.S.
	2-Year IST Industrial Warranty

INTERIOR VIEW

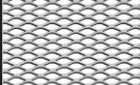

VISUAL	DESCRIPTION
	<p>Nylon sleeve gloves provide comfort and protection, and can be easily replaced when damaged. Dimension: 8" Diameter x 30" Length</p>
	<p>LED lighting system provides great visibility inside the cabinet while reducing substantially energy consumption. LED light strip produces up to 65% more lumens as opposed to traditional lighting system and consumes up to 90% less electricity.</p>
	<p>Trigger-operated G15 blast gun is designed to maximize operator's comfort due to its ergonomic handle. This blast gun uses interchangeable blast nozzles protected by a plastic adaptor.</p>
	<p>G15 blast gun is compatible with various ceramic, tungsten carbide and bore carbide nozzles. By default, ECONOBLAST® cabinets are delivered with a 5/16" I.D. ceramic nozzle (CN2-5).</p>
	<p>The bottom of the cabinet uses a metal screening to prevent oversized particles or objects from clogging the system.</p>

AVAILABLE OPTIONS

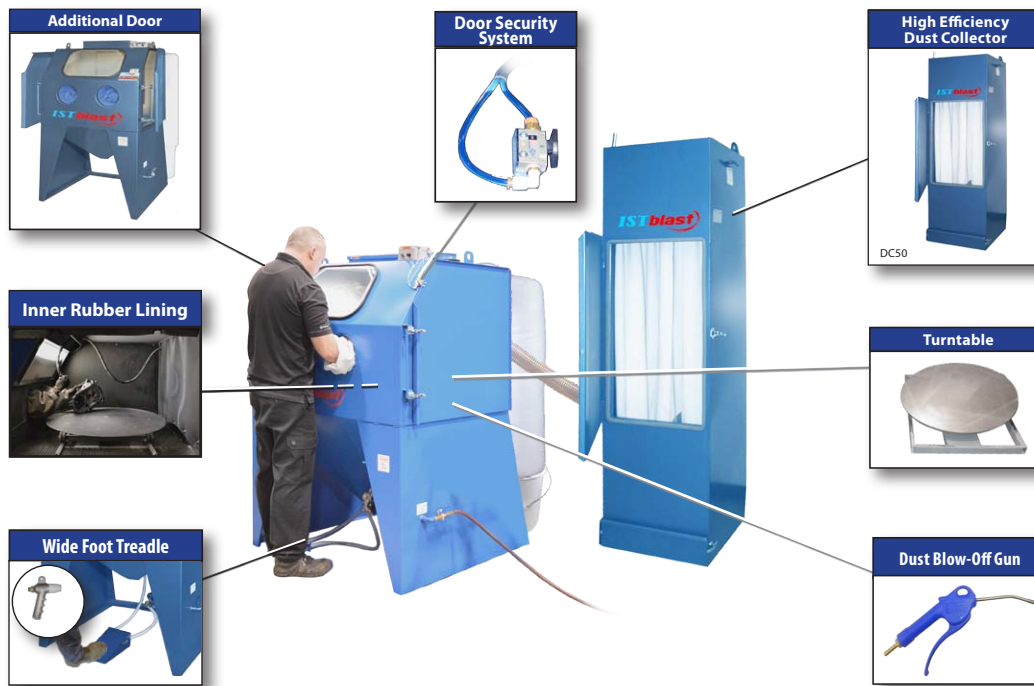

VISUAL	DESCRIPTION
	Additional side door on the left hand side provides a better access to the cabinet for loading /unloading parts.
	Safety-door switch prevents accidental blasting when the door is open.
	Air blow gun can be used to remove dust from the surface of the blasted part in order to avoid contaminating the work environment.
	High-efficiency DC Series dust collectors are available with 50 sq. ft. (DC50) filtering surface area and allow to capture 99% of all particles five (5) microns or larger. This collector is equipped with a manual shaker to clean filter bags.
	Fixed turntables facilitate parts handling inside the cabinet and optimize blasting performance of larger parts. They are available with charge capacities varying from 500 to 2,200 lbs.
	Wide foot treadle and G5 blast gun pupgrade kit enables operation with either foot.
	Rubber lining can be added to the cabinet inner panels in order to extend the equipment lifespan and reduce needs of maintenance.

DUST COLLECTORS

Standard dust collector



DB13 Dust Bag

High efficiency dust collector



DC50

FLOOR PLANS

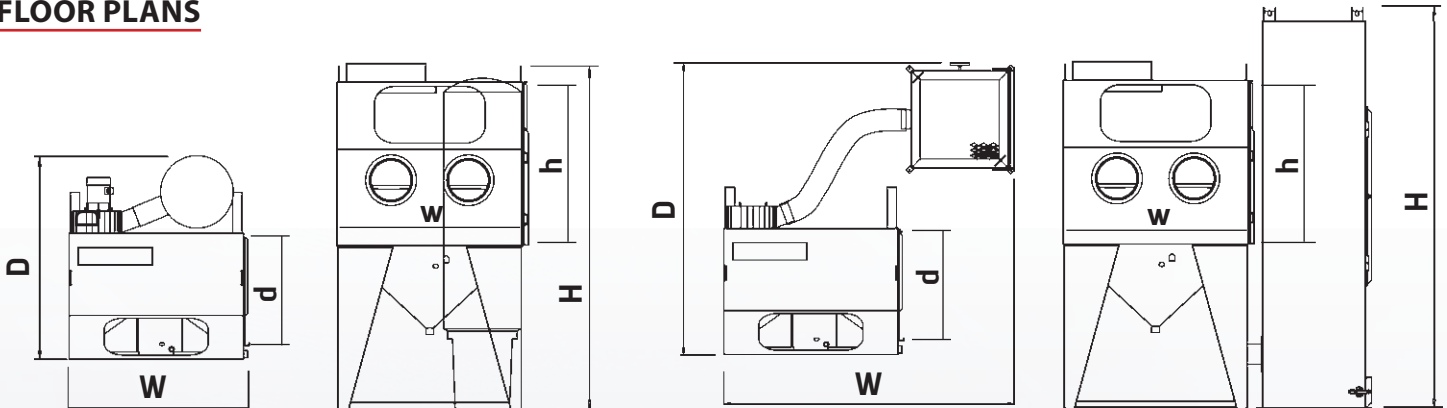

Overall dimensions with DB13 Dust Bag

Overall dimensions with DC50 Dust Collector

Specifications	ECONO 26		ECONO 28		ECONO 48	
Dust Collector	DB13	DC50	DB13	DC50	DB13	DC50
Part number	628104	628116	628157	628166	628257	628262
Fan motor (cfm)	400					
Filter Area (square feet)	13	50	13	50	13	50
Overall dim's (D x W x H)	42" x 36" x 67"	60" x 60" x 78"	44" x 44" x 67"	60" x 60" x 78"	52" x 36" x 67"	68" x 68" x 78"
Interior dim's (d x w x h)	26" x 36" x 30"		28" x 44" x 30"		36" x 48" x 31"	
Door opening (d x h)	20" x 29"		22" x 29"		30" x 29"	
Voltage	110 V / 1 ph / 60 Hz / 15 A					

AIR CONSUMPTION						
Pressure at the nozzle (psi) ¹	40	50	60	70	80	
Air Flow (cfm) ²	19	23	27	30	34	

¹psi: pound per square inch. Optimal working pressure for this equipment is **80 psi**.

²cfm: cubic feet per minute given for supplied 5/16" I.D. nozzle. Can consume less air when using smaller I.D. nozzle. Air consumption will increase as nozzle wears out.



ABOUT THE COMPANY

WHO WE ARE

IST is a leading industrial manufacturer of standard and custom engineered equipment for the surface treatment industry and the solvent recycling industry.

MISSION

IST is dedicated to being an innovative and trusted supplier in the conception, fabrication and distribution of surface treatment equipment and recycling equipment.

MARKETS SERVED

The products, technologies and industry expertise of IST are used in a wide range of manufacturing and industrial applications, including but not limited to :

- General Manufacturing
- Industrial Equipment
- Metal forming
- Aerospace and Aviation
- Rail and Transit
- Marine
- Automotive
- Petroleum
- Flexography (Labeling) & Lithography
- Wood finishing
- Power & Energy
- Pharmaceutical

