



ROTARY TABLE BLASTERS

Rotary Table Blasters are inexpensive sandblast systems designed to process a small batch of relatively flat parts.

The key advantages of this system include its simple operating principle and its flexibility, since workpieces within a batch can differ in shape and size, as long as they allow a minimum stand off distance from the nozzles.

ADVANTAGES

- Low initial cost
- Equipment has a small footprint
- Simple operating principle, simply load the parts and set the timer
- Can process several pieces at a time (batch cycle)
- Fully automated and tunable process
- Low-maintenance required

HOW IT WORKS

Parts are loaded on a motorized turntable and exposed to the blast stream for a predetermined period of time. Nozzles are usually mounted on a rotary head to provide optimal blast coverage all over the workpiece surface. Different nozzles arrangements can be configured as per the customer's request.

STANDARD FEATURES



Controlled by HMI

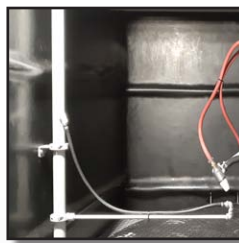

Air blowing manifold cleans parts after blast cycle



Abrasive media reclaiming system



Baghouse dust collector c/w barrer and muffler

OPTIONAL FEATURES



Rubber lining protection inside cabinet and cyclonic separator

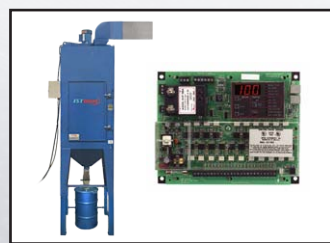

Baghouse dust collector package: automatic bag shaker, muffler, and dust collector barrel

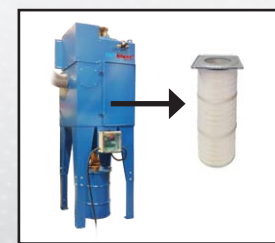

Cartridge dust collector upgrade (fully equipped)



INSIDE VIEWS

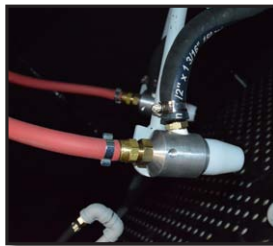
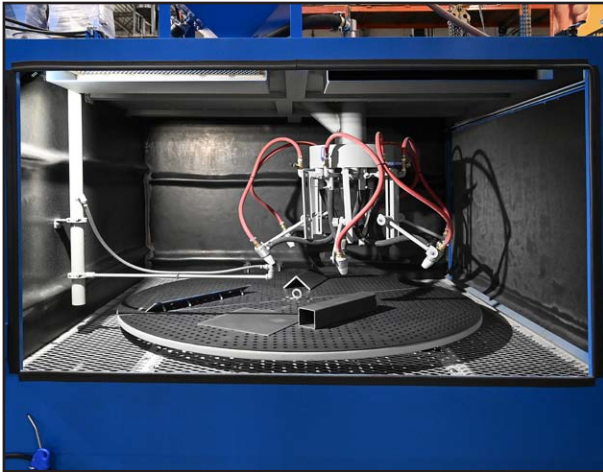

FLOOR LAYOUT

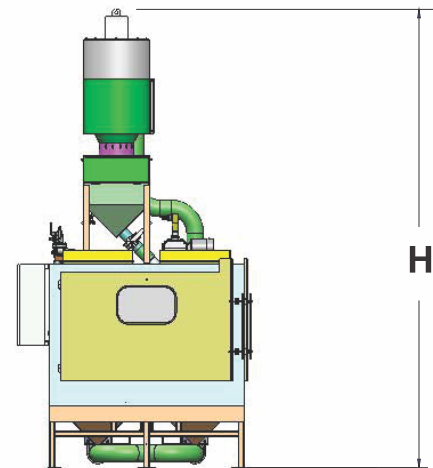
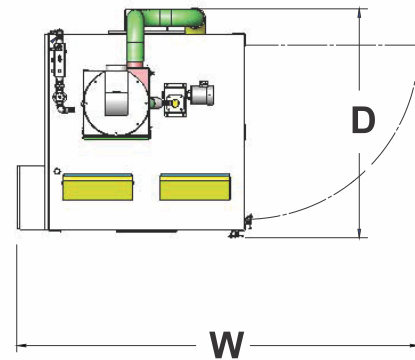

TECHNICAL SPECIFICATIONS

Description	M4848SRTH	M7272SRTH
Rotary Table Diameter	36"	60"
Standard Loading Capacity*	200 lb	
Overall Dimension with Door Open (W x D x H)**	104 1/2" x 59" x 146 1/2"	136 1/2" x 84 1/2" x 169 1/2"
Door Opening (W x H)	38" x 30"	62" x 38"
Available Voltages***	230 V, 480 V, or 600 V 3 Ph / 60 Hz	
Compressed Air Required for Nozzles	170 cfm @ 100 psig	260 cfm @ 100 psig
Rotary Head	Diameter 18", 4 nozzles	Diameter 30", 6 nozzles
Standard Dust Collector	Baghouse 99.5 % - 99.9 % 4 - 6 microns	

* Custom loading capacity available on demand

** Dimensions exclude dust collector

*** Monophase available on demand

CUSTOM DESIGN AVAILABLE UPON REQUEST

