



ABRASIVE BLAST ROOM MECHANICAL LOADING RECOVERY SYSTEM



TABLE OF CONTENTS

	Page
TABLE OF CONTENTS.....	2
KEY FEATURES.....	4
KEY FEATURES (CONT'D).....	5
INSIDE THE ROOM.....	6
R.O.I. (RETURN ON INVESTMENT).....	7
MEDIA RECOVERY SYSTEM.....	7
HOW IT WORKS.....	8
3-AXIS BLAST MEDIA / BLAST BOOTH LIFTS.....	9
SECURITY EQUIPMENT.....	10
CHOICE OF PRESSURE VESSELS.....	10
RECOVERABLE BLASTING MEDIA.....	11
AIR & ABRASIVE CONSUMPTION.....	11
BLAST ROOM DUST COLLECTORS.....	12
ABRASIVE BLAST ROOM SYSTEMS.....	13
ABOUT THE COMPANY.....	14

MECHANICAL LOADING RECOVERY SYSTEM

HOW IT WORKS

The mechanical loading recovery system is the ideal solution for extremely large abrasive blast rooms with limited budgets or to maximize productivity in facilities where excavation is not allowed. Abrasive residues must be loaded mechanically in a discharge hopper in order to be recovered by the system. It is a high-efficiency system that is also inexpensive to implement and to maintain since it has only few mechanical components.

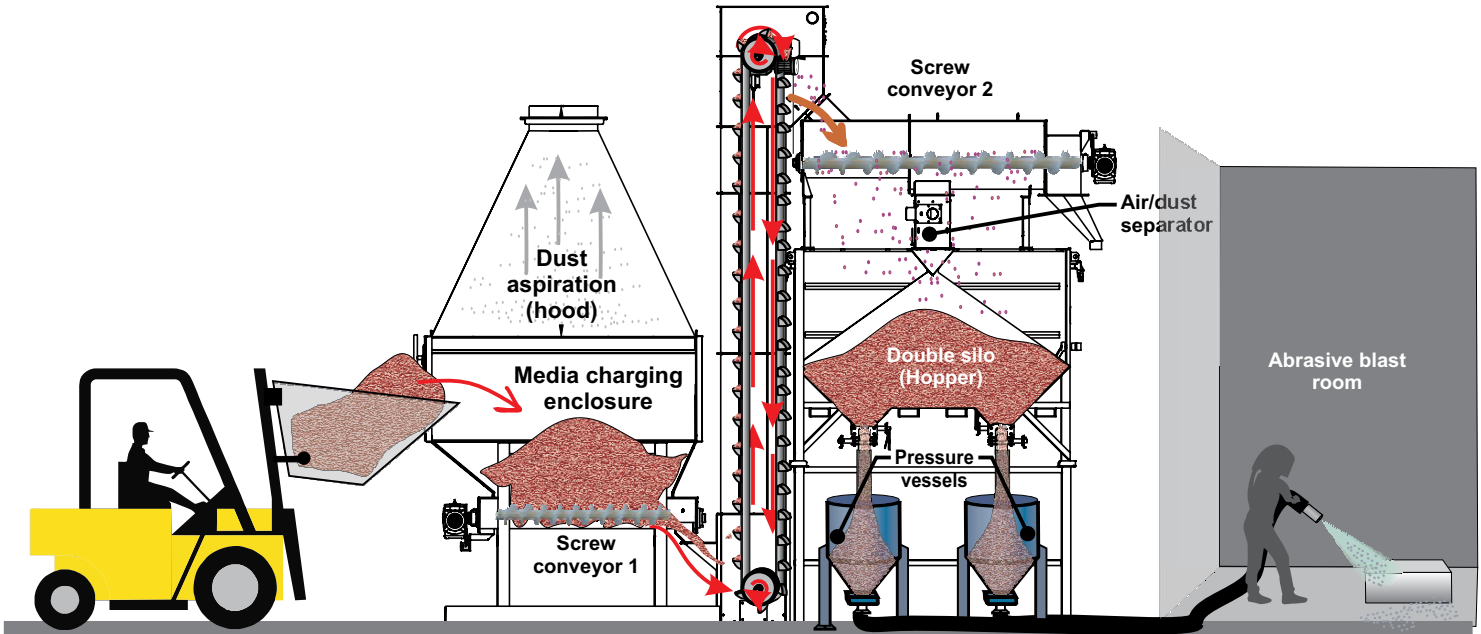

KEY POINTS

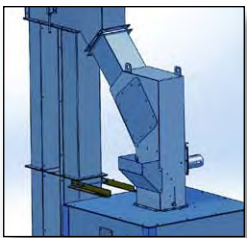

100% adjustable abrasive air wash



Bucket elevator



Double silo & Pressure vessel



Recovery system capacity
3,300 lb/h



Can handle all types of abrasives



Screw Conveyor

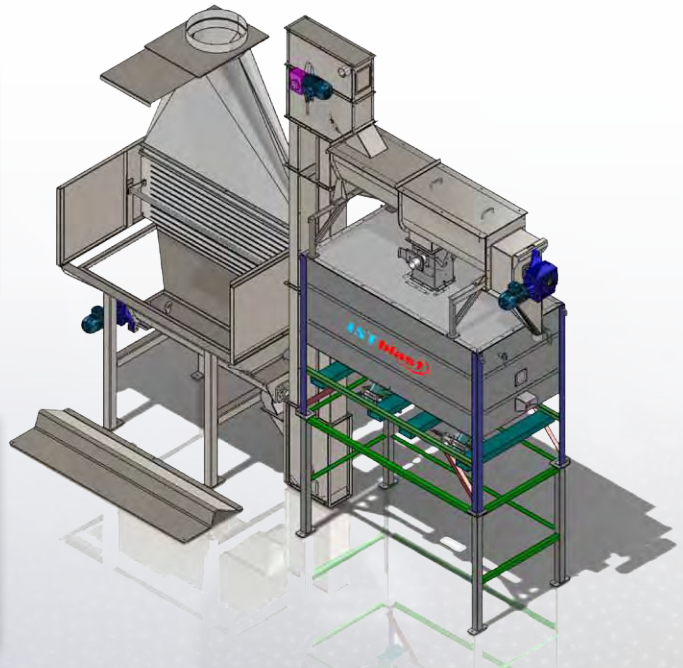





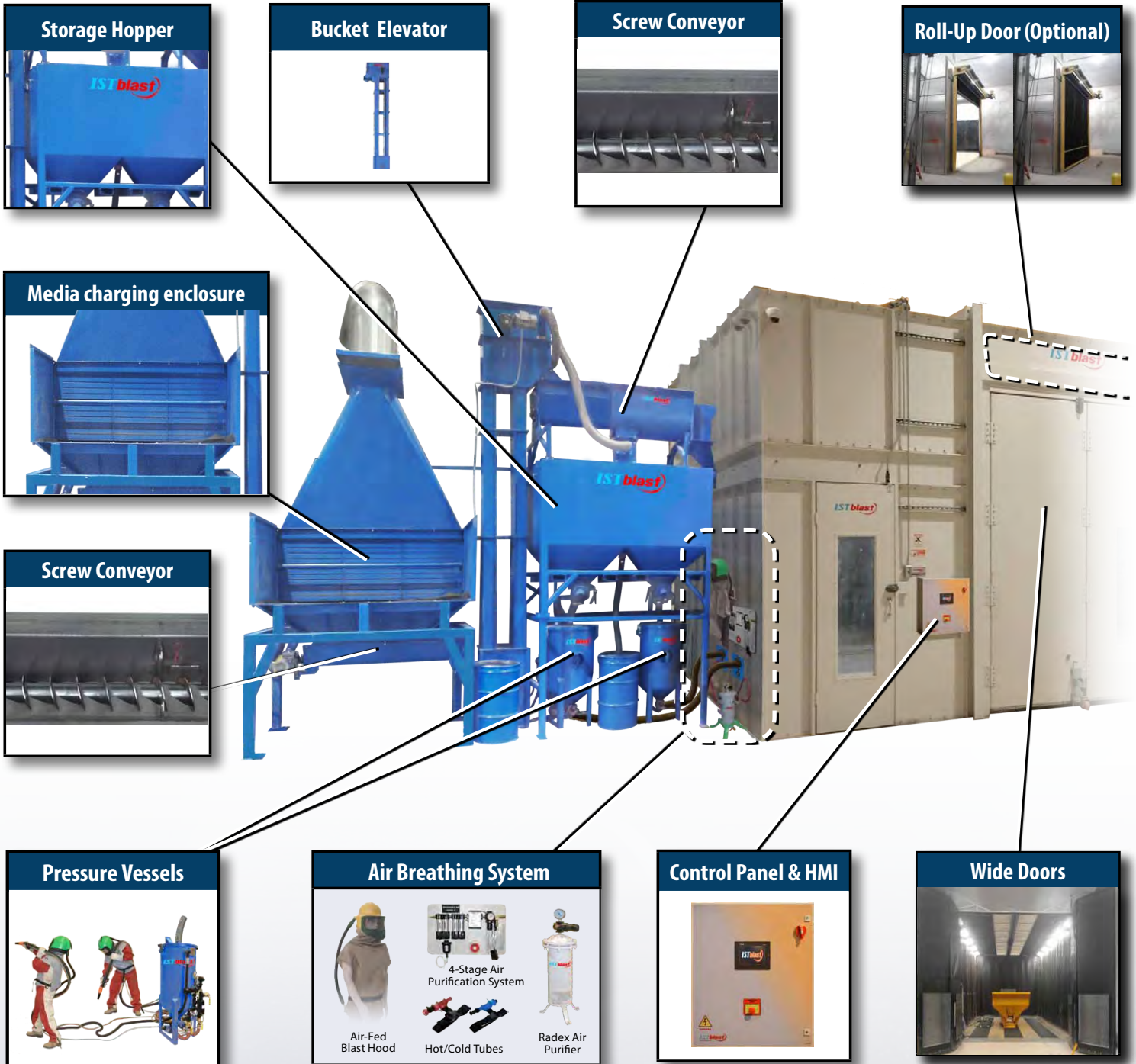



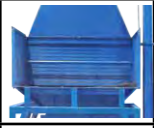

Discharge hopper integrated to the recovery system

KEY FEATURES







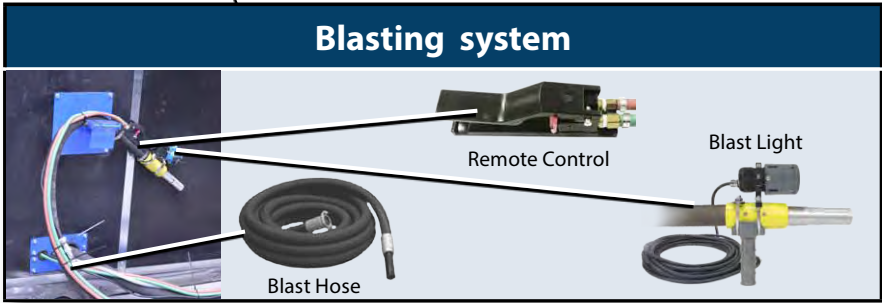
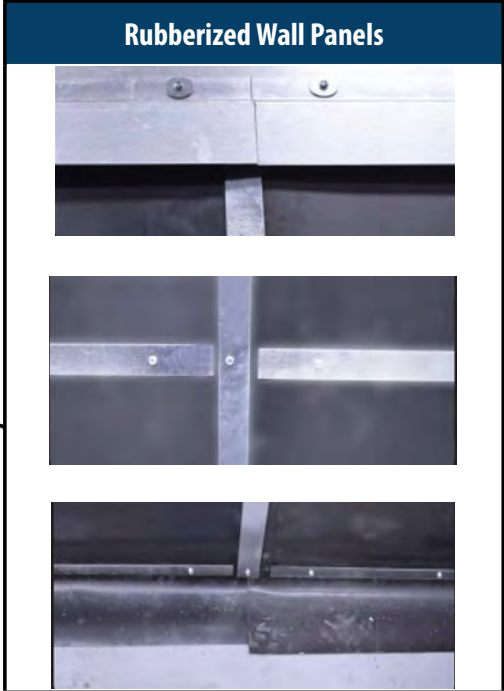
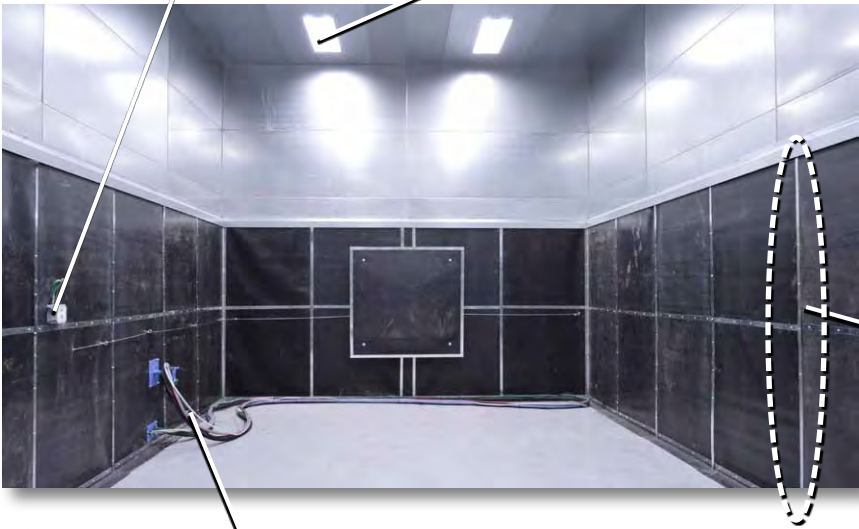

KEY FEATURES (CONT'D)

VISUAL	DESCRIPTION
	<p>Roll-Up Door (Optional) Durable roll-up rubber doors designed to withstand harsh environment and requiring minimal maintenance.</p>
	<p>Wide doors opening and low footprint door system to enter large parts into the room.</p>
	<p>Screw Conveyor</p>
	<p>Bucket Elevator</p>
	<p>Double Storage Hopper provides long hours of blasting autonomy.</p>
	<p>Media Charging Enclosure</p>
	<p>Pressure vessel in a various selection can supply up to 2 operators.</p>
	<p>Control panel with HMI</p>
	<p>Air Fed Hood provides comfort and respiratory protection for long hours of blasting.</p>
	<p>Hot/Cold Tubes temperature control warm up / cool down breathable air supplied for increase comfort.</p>
	<p>4-stage purification system provides grade « D » air and detects carbone monoxide.</p>
	<p>Radex Air Purifier removes 98% of particles down to 0.5 micron size.</p>

INSIDE THE ROOM



VISUAL	DESCRIPTION
	Depress switch allows operator to fill the pressure vessel without leaving the room.
	High efficiency LED lighting system producing 65% more lumens and consuming 90% less energy.
	Tightly sealed rubberized panels protecting the inside of the blast room.

VISUAL	DESCRIPTION
	Durable 50' blast hose.
	Pneumatic remote control at the nozzle to operate blasting.
	LED auxiliary lighting system for better visibility.

MEDIA RECOVERY SYSTEM

All our abrasive blast rooms are delivered with a media recovery system. Following the blasting process, residual abrasives accumulated can be vacuumed, swept or shoveled into the recover pit.

Collected used abrasive is conveyed to an adjustable abrasive separator to be cleaned and recycled. Reusable abrasive is then returned to the pressure vessel to be used again, while dust and fine particles are evacuated to the filtration system.

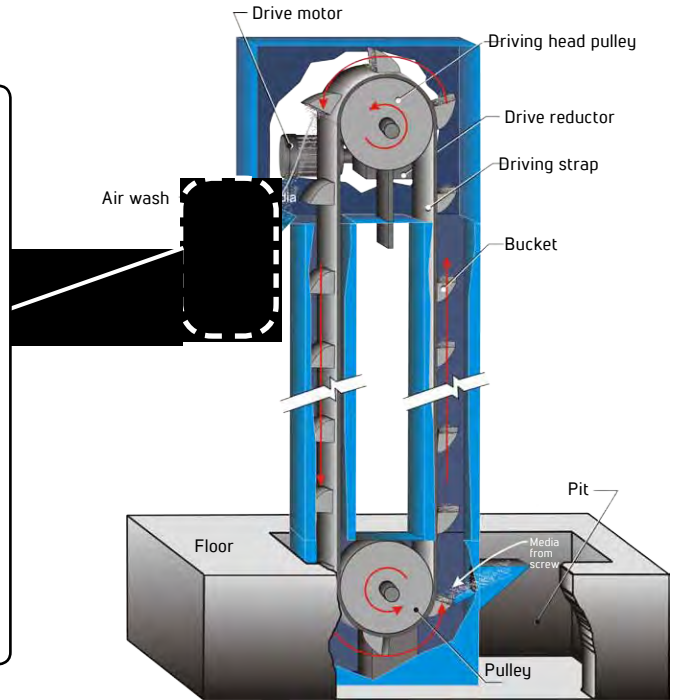
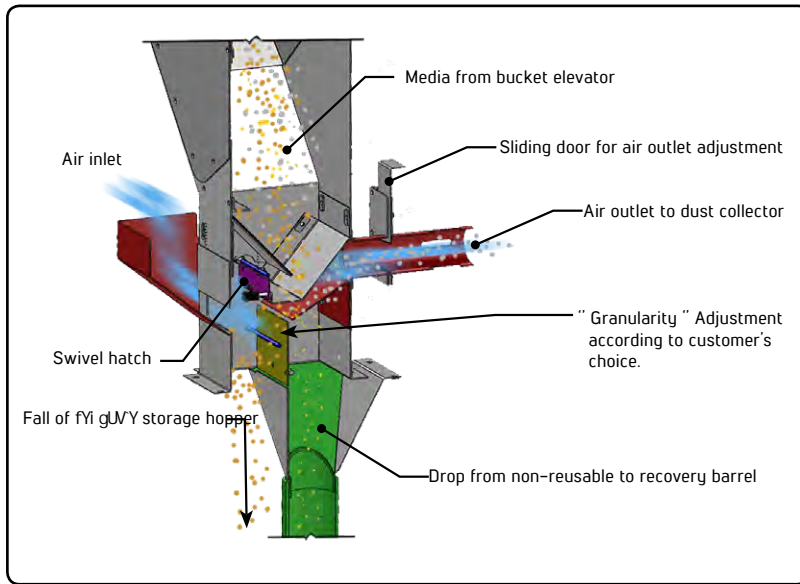

R.O.I. (RETURN ON INVESTMENT)

Recycling abrasives enables the user to achieve considerable savings in abrasives consumption while protecting the environment from harmful sandblasting dust.

Steel grit abrasives can be recycled and used up to 100 times compared to only one use with non-recyclable media. The non-recyclable sandblasting abrasives are low in cost, but they can only be used for one sandblasting cycle. Because of their fragile molecular structure, they deteriorate quickly while generating harmful sandblasting dust and significantly reduce the visibility of the operators.

Recyclable Abrasives vs Non-Recyclable Abrasives Example

DESCRIPTION	SILICA SAND	STEEL GRIT	SAVINGS \$/ DAY
Pounds per day	4 000	4 000	4 000
Abrasive (price/lb) x % breakdown	(\$0.12 x 4000) x 100 % = \$ 480	(\$0.75 x 4000) x 5 % = \$ 150	\$ 330.00
Cleaning	4h x \$ 25	2 h x \$ 25	\$ 50.00
Abrasive disposal cost	\$8 / day	\$0.40 / day	\$ 7.60
Additional electrical cost (600 V – 8 A)	\$0.00 / day	\$6.00 / day	- \$ 6.00

Total savings per day : \$ 381.60

HOW IT WORKS

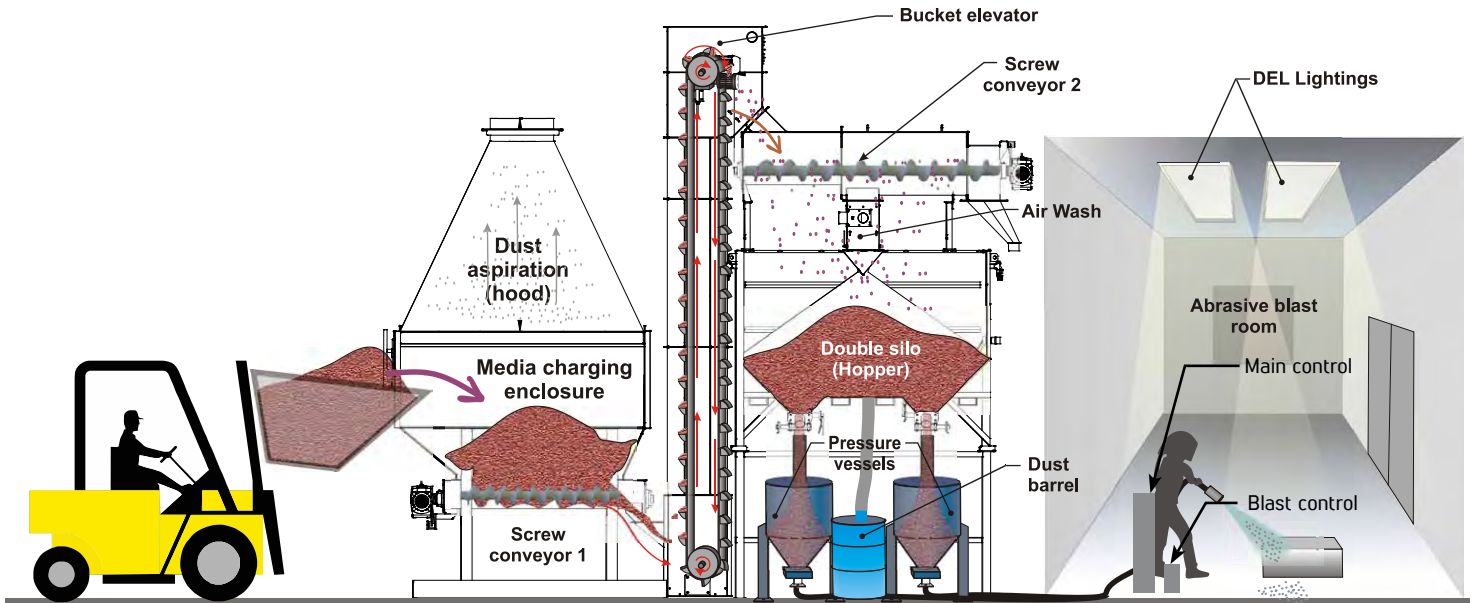

ISTblast rooms mechanical recovery systems come complete with enclosure, bucket elevator, air-wash abrasive cleaner, media storage hopper, cartridge dust collector, blasting pot and 4 stage air breathing system. Most commonly used for shot blasting or shot peening, our bucket elevator recovery systems can be configured with one or two blast pots, or as a stand-alone unit to use with your existing sand blasting pot. A vibrating screen is available as an option.

ISTblast bucket elevators can process up to 200 cubic feet per hour of dense and coarse media, such as steel grit and steel shot. Our hopper and bucket elevator recovery systems can be flush mounted for easy loading by placing the bucket elevator and hopper in a small pit.

RECYCLABLE ABRASIVES

TYPE OF ABRASIVE	HARDNESS	DURABILITY	DENSITY
Glass Beads	50-60 Rc (5-7 Mohs)	5-8 cycles	2.6 g/cc
Stainless Steel Shot	20 Rc (work hardens to 60 Rc)	3500-4500 cycles	7.0 g/cc
Plastic Media	3-4 Mohs	4-6 cycles	1.5 g/cc
Aluminium oxide	50-65 Rc (5-7 Mohs)	25-40 cycles	3.7 g/cc
Ultra Soft Shot	3-3.5 Mohs	6000-7000 cycles	7.4 g/cc

3-AXIS BLAST MEDIA / BLAST BOOTH LIFTS

BL lifts are designed to withstand the harsh environment of grit, sand, and shot blast booths. Manufactured with sealed components and lift mast along with heavy duty components, the lifts can replace ladders providing increased safety and productivity. This efficient design can be used to reach heights of up to 27 feet.



- Customizable raised-platform heights up to 20 feet
- Retracted dimension 4'-0"
- Extended dimension 9'-0"
- Operator platform capacity 500 lb
- Sealed mast construction
- Pneumatic/hydraulic power unit
- Platform 48" wide x 30" deep
- Operator controls on front rail of platform
- Hand controls for Y-Axis, Z-Axis, and emergency stop
- Foot control for X-Axis
- Base control to raise and lower platform
- Lift equipped with Filter/Regulator/Lubricator
- Self-closing/self latching entry gates
- 1 and 2 axis models available
- Lift requires a clean, dry air supply of 80 scfm @ 100 psi with a 40° F dew point.

Travel Speeds :

- X-Axis variable up to 40 fpm
- Y-Axis 15 fpm
- Z-Axis 15 fpm

Extended reach model :

- Retracted dimension 4'-6"
- Extended dimension: 13'-4"
- Operator platform capacity: 400 lb

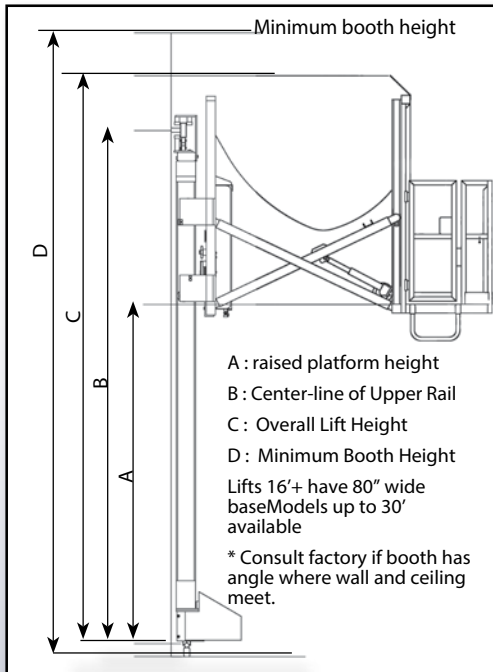

Fully Extended Dimension 9' (Y-Axis) Extended Reach Model 13'-4"» Fully Extended (Y-Axis)				
Model	A	B	C	D
BL-89	8'- 0"	12'- 11¼"	14'- 6"	15'
BL-99	9'- 0"	13'- 11¼"	15'- 6"	16'
BL-109	10'- 0"	14'- 11¼"	16'- 6"	17'
BL-119	11'- 0"	15'- 11¼"	17'- 6"	18'
BL-129	12'- 0"	16'- 11¼"	18'- 6"	19'
BL-139	13'- 0"	17'- 11¼"	19'- 6"	20'
BL-149	14'- 0"	18'- 11¼"	20'- 6"	21'
BL-159	15'- 0"	19'- 11¼"	21'- 6"	22'
BL-169	16'- 0"	20'- 11¼"	22'- 6"	23'
BL-179	17'- 0"	21'- 11¼"	23'- 6"	24'
BL-189	18'- 0"	22'- 11¼"	24'- 6"	25'
BL-199	19'- 0"	23'- 11¼"	25'- 6"	26'
BL-209	20'- 0"	24'- 11¼"	26'- 6"	27'

CHOICE OF PRESSURE VESSELS

We offer different options and configurations of pressure vessels to accommodate your needs and maximize your productivity.



PPB 646

PPB 1046
(up to 2 operators)

Specifications	PPB 646	PPB 1046
Loading capacity (A.S.M.E.)	6.5 cu.ft.	10 cu.ft.
Tank diameter	24"	24"
Media loading (abrasive)	600 lb.	1,000 lb.
Length x height x width	32" x 50" x 35"	32" x 66" x 35"
Weight	350 lb.	575 lb.
Number of operators	1	1 or 2

CONFIGURATION OPTIONS	
Pressure hold system	Pressure release system
<ul style="list-style-type: none"> ✓ No depressurization when blasting operations stop ✓ Reduces air consumption ✓ Convenient for frequent start/stop operations ✓ Even abrasive flow when starting operations 	<ul style="list-style-type: none"> ✓ Pressure vessel automatically depressurizes when blasting operation stop ✓ Automatic filling of the pressure vessel, without any intervention ✓ Less wear-and-tear for the abrasive metering valve ✓ Simplified and cheaper maintenance
Double Control system	
<ul style="list-style-type: none"> ✓ Combined system offers the advantages of both configurations without the disadvantages. 	

UPGRADE KIT



UPGRADE TO MAXBLAST FOR MORE POWER AND BLASTING SURFACE



Coupling



Automatic Air Valve

Maxblast upgrade kit includes an automatic air valve and fitting that allows you to install a 1 1/2" blast hose which increases air pressure at the nozzle, reduces pressure losses and increases operator productivity.

BENEFITS OF MAXBLAST

- Reduction of pressure losses from 24% to 27%
- Increased in productivity (blasting time) from 36% to 40%

SECURITY EQUIPMENT

IST provides a 4-stage filtration system to provide breathable air to the operator's hood, eliminating air contaminants such as oil vapors, hydrogen gases, rust and other potentially hazardous contaminants to provide pure compressed air of respirable quality.

This system is equipped with an air supply detector and a carbon monoxide detector which continuously monitors and samples the air supplied in accordance with OSHA standards.

4-STAGE AIR BREATHING SYSTEM

BREATHABLE AIR HOOD

SANDBLASTING SUITS

BLAST LIGHTS



LED blast light

AIR & ABRASIVE CONSUMPTION

PRESSURE

Opening	psi ¹	30	40	50	60	70	80	90	100°
1/8"	cfm ²	8	10	11	13	15	17	19	20
	lb/h ³	55	69	84	97	110	127	140	154
3/16"	cfm ²	18	22	26	30	33	38	41	45
	lb/h ³	130	160	170	192	220	243	268	297
1/4"	cfm ²	34	41	47	54	61	68	74	81
	lb/h ³	219	276	302	351	398	460	504	556
5/16"	cfm ²	53	65	77	89	101	113	126	137
	lb/h ³	410	495	526	601	680	756	832	910
3/8"	cfm ²	76	91	108	126	143	161	173	196
	lb/h ³	570	710	750	860	970	1080	1184	1296
7/16"	cfm ²	100	124	147	170	194	217	240	254
	lb/h ³	770	840	1008	1160	1320	1476	1630	1782
1/2"	cfm ²	137	165	195	224	252	280	309	338
	lb/h ³	1015	1230	1305	1500	1700	1890	2088	2277
5/8"	cfm ²	212	260	308	356	404	452	504	548
	lb/h ³	1325	1600	1875	2140	2422	2690	2973	3250

RECOVERABLE BLASTING MEDIA

SPHERICAL SHAPED MEDIA

Ceramic Beads	Glass Beads	Stainless Shot	Steel Shot

ANGULAR SHAPED MEDIA

Aluminium Oxide	Ceramic Grit	Crushed Glass	Garnet	Plastic Media	Silicon Carbide	Stainless Grit	Steel Grit	Walnut Shells

MEDIA GUIDE

	Glass Beads	Ceramic Grit	Stainless Cut Wire	Steel Shot	Steel Gri	Alumi-nium Oxide	Silicon Carbide	Garnet	Crushed Glass	Plastic Media	Walnut Shells
Finishing	YES	YES	YES	YES	YES	YES	YES	YES	YES	NO	NO
Cleaning/Removal	YES	YES	YES	YES	YES	YES	YES	YES	YES	YES	YES
Peening	YES	YES	YES	YES	NO	NO	NO	NO	NO	NO	NO
Surface Profiling (Etch)	NO	NO	YES	NO	YES	YES	YES	YES	YES	YES	YES
Working Speed	MED.	MED.	MED.	MED.	MED.-HIGH	HIGH	VERY HIGH	HIGH	HIGH	MED.-HIGH	LOW-HIGH
Recyclability	HIGH-LOW	HIGH	HIGH	VERY HIGH	VERY HIGH	MED.-HIGH	MED.-LOW	MED.	MED.-LOW	MED.	LOW
Probability of Metal Removal	VERY LOW	VERY LOW	VERY LOW	VERY LOW	MED.	MED.-HIGH	MED.-HIGH	MED.	LOW-MED.	VERY LOW	VERY LOW
Hardness, MOH Scale (Rockwell RC)	5.5	7 (57-63)	6-7.5 (35-55)	6-7.5 (35-55)	8-9 (40-66)	8-9	9	8	5.5	3-4	1-4.5
Bulk Density (lb/cu.ft.)	100	150	280	280	230	125	95	130	100	45-60	40-80
Mesh Size	30-440	8-46	20-62	8-200	10-325	12-325	36-220	16-325	30-400	12-80	MANY
Typical Blast Pressure	20-55	20-90	20-90	20-90	20-90	20-90	20-90	30-80	20-50	20-60	10-40
Shapes : or 										or	

* Above information is intended as a general reference guide

BLAST ROOM DUST COLLECTORS

IST offers a wide selection of fully equipped blast room dust collectors with up to 50,000 cfm in capacity.

Our vertical design and pulsation system provide a more efficient means to remove dust from cartridges, eliminating uneven dust accumulation associated with horizontally mounted cartridges.



DCM 3,000 to 50,000



Simple and safe cartridge replacement system requiring no tools.



Automatic Pulse Cartridge Cleaner. A light illuminates to indicate when the cartridges must be replaced.



Optional screw conveyor to collect dust inside the building

DIFFERENT TYPES OF DUST EXTRACTION DUCTINGS

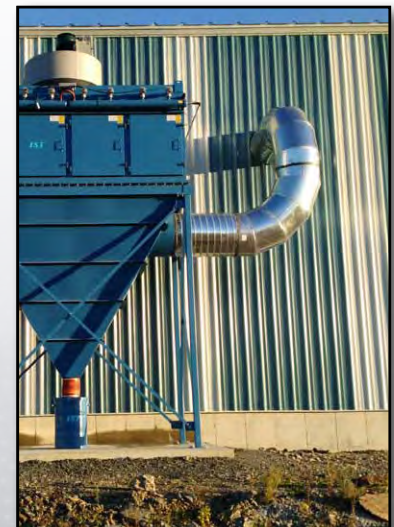

ABRASIVE BLAST ROOM SYSTEMS

We offer a wide range of customized solutions to meet any need.



Full floor

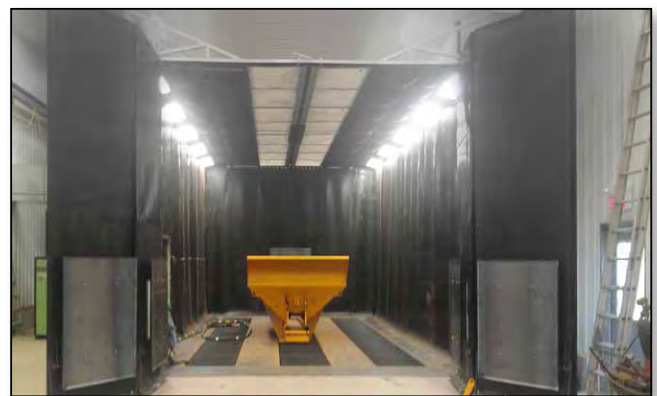

Triple or dual recovery floor



Partial recovery floor

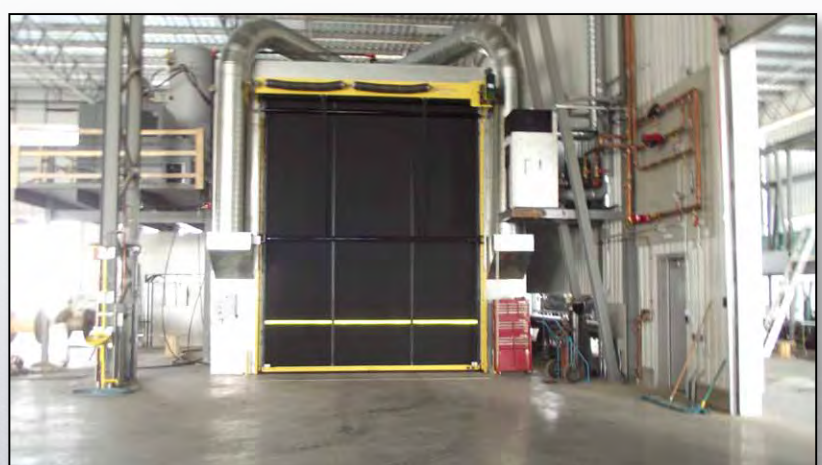

Roll up doors

ABOUT THE COMPANY

WHO WE ARE

IST is a leading industrial manufacturer of standard and custom engineered equipment for the surface treatment industry and the solvent recycling industry.

MISSION

IST is dedicated to being an innovative and trusted supplier in the conception, fabrication and distribution of surface treatment equipment and recycling equipment.

MARKETS SERVED

- General Manufacturing
- Industrial Equipment
- Metal forming
- Aerospace and Aviation
- Rail and Transit
- Marine
- Automotive
- Petroleum
- Flexography (Labeling) & Lithography
- Wood finishing
- Power & Energy
- Pharmaceutical

