

SANDBLASTING CABINET - ECAB SERIES
240 V



- Warranty
- Safety
- Operation
- Service Parts
- Accessory Information
- Registration Form



INSTRUCTION MANUAL

TABLE OF CONTENTS

	Page
CABINETS SPECIFICATIONS.....	3
NOTICE TO PURCHASERS AND USERS OF OUR PRODUCTS AND THIS INFORMATIONAL MATERIAL.....	4
SAFETY AND WARNING.....	4
DANGER AND WARNING LABELS	5
GENERAL SAFETY RULES	6
INSTALLATION.....	7
PNEUMATIC CONNECTION.....	7
ELECTRICAL CONNECTIONS.....	8
ABRASIVE MEDIA LOADING.....	9
OPERATION	10
SHUT DOWN - CHANGING THE MEDIA	11
RECLAIMER.....	12
MAINTENANCE CABINET AND DUST COLLECTOR.....	13
NOZZLE AND JET MAINTENANCE	14
TROUBLESHOOTING.....	15 TO 18
SCHEMATIC OF UNIT- EXPLODED VIEW & PARTS.....	19
STANDARD G5 BLAST	20
FOOT PEDAL WITH PILOT VALVE - OPTIONAL SH5 BLAST GUN	21
OPTIONNAL BAGHOUSE DUST COLLECTOR DC50 - GENERAL PARTS LIST	22
OPTIONNAL BAGHOUSE DUST COLLECTOR DC100 - GENERAL PARTS LIST	23
RECOMMENDED SPARE PARTS.....	24
PNEUMATIC DIAGRAM.....	25
ELECTRICAL SCHEMATIC - 1 PH / 240 V - DRAWING	26
ELECTRICAL SCHEMATIC - 1 PH / 240 V - PARTS LIST.....	27
ISTBLAST LIMITED WARRANTY	28
ISTBLAST WARRANTY REGISTRATION.....	29
INFORMATION- TECHNICAL ASSISTANCE	30
OUR MAP LOCATION.....	31
ABOUT THE COMPANY	32

CABINETS TECHNICAL DATA

GENERAL SPECIFICATIONS	
Cabinet Construction	1.628 mm gauge
Floor Capacity	227 kg
Gloves	Nylon, 254 mm diameter
Blasting System	Foot Pedal
Piping	12.7 mm diameter
Nozzle	CN2-5 Ceramic, 7.94 mm I.D.
Blast Gun	G5
Abrasive Regulator	AR-3/4
Pressure Regulator/ Gauge	Standard
Glass	356 mm x 559 mm
Motor (ch)	1/2
Fan (m ³ /h)	680

MODEL	ECAB 2636S	ECAB 3636S	ECAB 3648S	ECAB 4848S
WORK AREA (D X W X H) (mm)	660 x 914 x 813	914 x 914 x 813	914 x 1219 x 813	1219 x 1219 x 813
OVERALL DIMENSIONS (D X W X H)				
WITH DB13 (mm)	1346 x 1067 x 1702	1600 x 1067 x 1702	1600 x 1372 x 1702	1905 x 1372 x 1702
WITH DC50 (mm)	1448 x 1524 x 1981	1702 x 1524 x 1981	1702 x 1829 x 1981	2006 x 1829 x 1981
WITH DC100 (mm)	1600 x 1575 x 2311	1854 x 1575 x 2311	1854 x 1880 x 2311	2159 x 1880 x 2311
DOOR OPENING (W X H) (mm)	508 x 737	762 x 737		1067 x 737
WEIGHT (kg)	184	202	212	225

NOTICE TO PURCHASERS AND USERS OF OUR PRODUCTS AND THIS INFORMATIONAL MATERIAL

The products described in this material, and the information relating to those products, is intended for knowledgeable, experienced users of abrasive blasting equipment.

No representation is intended or made as to the suitability of the products described herein for any particular purpose of application. No representations are intended or made as to the efficiency, production rate, or the useful life of the products described herein. Any estimate regarding production rates or production finishes are the responsibility of the user and must be derived solely from the user's experience and expertise, and must not be based on information in this material.

The products described in this material may be combined by the user in a variety of ways for purposes determined solely by the user. No representations are intended or made as to the suitability or engineering balance of the combination of products determined by the user in his selection, nor as to the compliance with regulations or standard practice of such combinations of components or products.

It is the responsibility of the knowledgeable, experienced users of the products mentioned in this material to familiarize themselves with the appropriate laws, regulations and safe practices that apply to these products, equipment that is connected to these products and materials that may be used with these products.

It is the responsibility of the user to insure that proper training of operators has been performed and a safe work environment is provided.

Our company is proud to provide a variety of products to the abrasive blasting industry, and we have confidence that the professionals in our industry will utilize their knowledge and expertise in the safe efficient use of these products.

SAFETY AND WARNING

GENERAL SAFETY

1. Carefully inspect the shipping carton for any signs of transport damage. The damage to the carton often indicates possibility of transport damage to the equipment inside.
2. Carefully remove your IST SANDBLASTING CABINET from the shipping carton and skid.
3. Check your equipment immediately to ensure that it is free of transport damage. Report any transport damage to the carrier without delay for possible claim procedures. International Surface Technologies inc. is not responsible for damage to equipment after it leaves our warehouse.
4. Check the equipment and compare it with the parts you have received. If any parts are missing, contact the supplier you purchased the equipment from.

Before operating the IST SANDBLASTING CABINET, read this Instruction Manual completely. All IST products are engineered and manufactured to the highest performance standards and have been subjected to detail testing before shipment from the factory.

DANGER AND WARNING LABELS

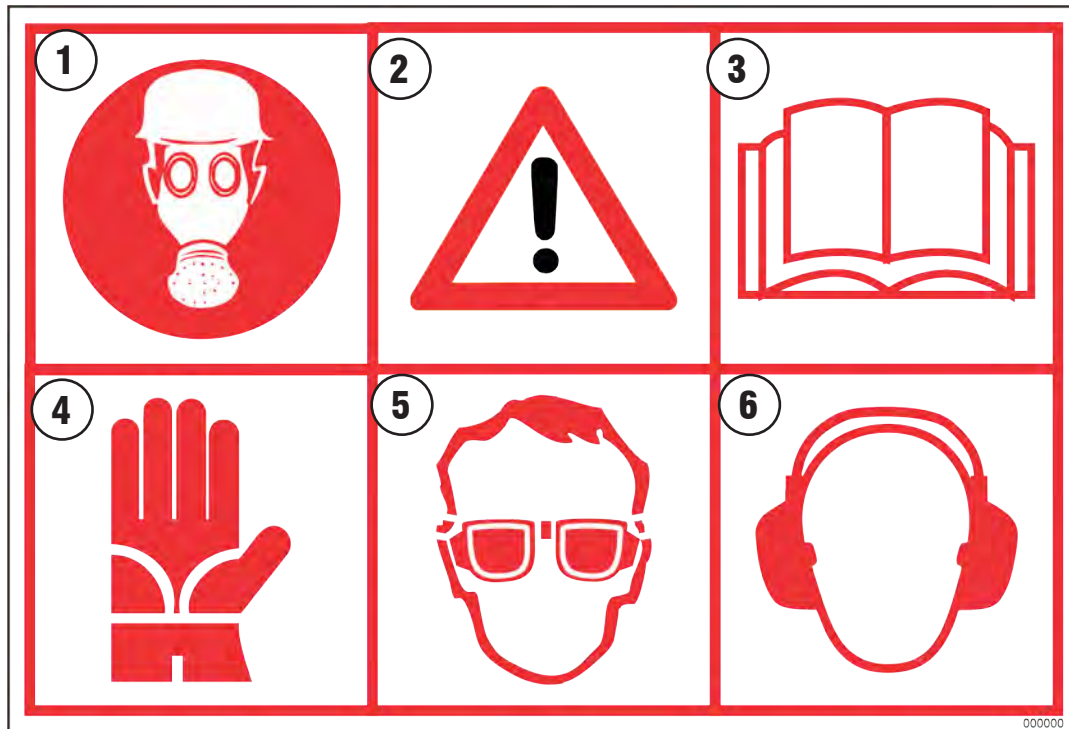

1. Wear breathing mask
2. Observe warnings at all times.
3. Read the Instruction Manual carefully.
4. Wear rubber gloves.
5. Wear protective eyewear before use
6. Wear earing protection before use

WARNING

« READ ALL INSTRUCTIONS » Failure to follow the SAFETY RULES identified by a BULLET (●) symbol listed BELOW and other safety precautions may result in serious personal injury.

« SAVE THESE INSTRUCTIONS »

GENERAL SAFETY RULES

- **KEEP WORKING AREA CLEAN.**
- **KEEP CHILDREN AWAY.** Do not let visitors come in contact with the equipment. All visitors should be kept away from the work area.

PERSONAL SAFETY

WARNING

SANDBLAST CABINET MAY EMIT POTENTIALLY HAZARD DUST AND AIRBORNE CONTAMINANTS DURING OPERATION. YOU MUST WEAR APPROPRIATE BREATHING PROTECTION AT ALL TIMES WHILE OPERATING OR STANDING AROUND THE UNIT.

- **GUARD AGAINST ELECTRIC SHOCK.** Non-skid footwear is recommended where damp or wet ground may be encountered. A ground fault circuit interrupter protected power line must be used for these conditions.
- **DRESS PROPERLY.** Do not wear loose clothing or jewelry. They can be caught in the moving parts. Wear protective hair covering to contain long hair
- **USE SAFETY EQUIPMENT. WEAR SAFETY GOGGLES** or glasses with side shields.
- **WEAR A DUST PROOF MASK. .**
- **STAY ALERT. USE YOUR COMMON SENSE.** Concentrate on what you are doing. Do not operate the unit when you are tired or under the influence of drugs
- **DO NOT OVERREACH THE EQUIPMENT.** Keep proper footing and balance at all times.
- **BEFORE STARTING TO WORK** you must wear earing protections, efficient for 80 dB or more.

UNIT USE AND CARE

- **DO NOT FORCE THE UNIT.** It will perform better and safer at the rate for which it was designed.
- **THE USE OF ANY OTHER ACCESSORIES** not specified in this manual may create a hazard.
- **CLOSE THE MAIN BREAKER SWITCH BEFORE SERVICING** or when not in use.
- **DO NOT ALTER OR MISUSE THE UNIT.** These units are precision built. Any alteration or modification not specified is misuse and may result in a dangerous situation.

Only trained repairmen should attempt (●) **ALL REPAIRS**, electrical or mechanical. Contact the nearest IST ISTblast repair service facility. Use only IST ISTblast replacement parts; any other parts may create a hazard.

ENVIRONMENTAL CONDITIONS FOR WHICH THE EQUIPMENT IS DESIGNED

- Indoor location
- Altitude: 2 000 m max.
- Ambient temperature: 40 °C max
- Relative humidity: 80 %
- Main supply voltage fluctuation: +/- 10 %
- To use with non combustible dust only

INTRODUCTION

Welcome to the IST family of sandblasting products. This booklet contains helpful information and acquaints you with the operation and maintenance of your equipment. Please read carefully and follow our recommendations to assure trouble free operation. If you have any questions, please do not hesitate to contact your distributor or our technical service.

INSTALLATION

1. Unbolt the blast cabinet from the pallet. Attach a strap or a hoist to the eyelets located on the top of the machine and move it to its final location using a lift truck or a crane.
2. Make sure the cabinet is leveled and well grounded. Do not place on a wooden floor or a rubber mat, unless a ground wire has been installed. Check with a qualified electrician.
3. Place the system to the installation location
4. Unwrap and remove the cabinet from the pallet
5. Insure there is adequate space on both sides of the cabinet for full opening of part loading/unloading and maintenance access doors.
6. Insure that there is adequate space at both sides of the system for easy access to components such as the reclaimer and dust collector
7. The dust collector should be located on a leveled area near the back of the cabinet, on the right side (while facing cabinet). Attach one end of the corrugated discharge hose to the outlet of the reclaimer and the other end to the inlet located at the bottom of the dust collector. Secure both ends with the supplied clamps. See dust collector section for more details

All IST ECAB Series cabinets are equipped with a dust collector and a 680 m³/h fan motor.

PNEUMATIC CONNECTION

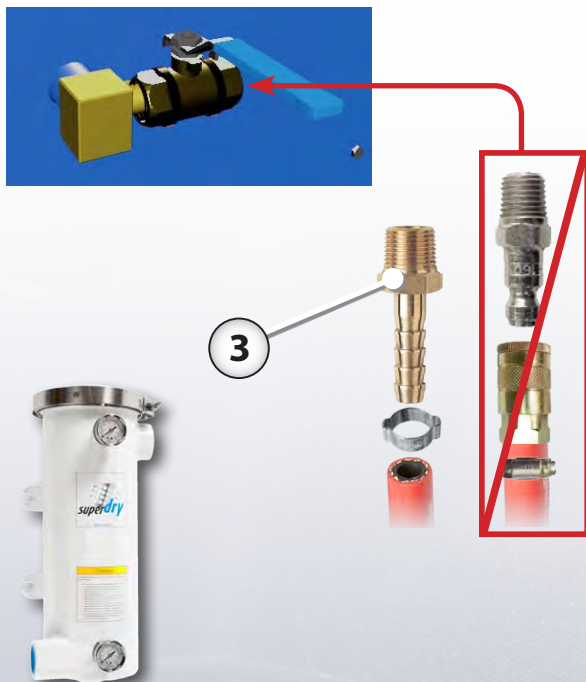

Air dryer

Connect your shop's air supply line to the air inlet. The hose should have a minimum of 12.7 mm inside diameter. Never use male-female quick couplings. Choose couplings that offer as little restriction to the airflow as possible.

To properly operate, your IST system use clean, dry air. Moisture or oil from the compressed air supply can contaminate the abrasive, and prevent it from flowing freely and cause inefficient blasting.

CAUTION If you use interlocking connections, secure them with pins. A connection that disconnects under pressure, could cause serious injury.

ELECTRICAL CONNECTIONS

Connect cabinet power supply cord to standard 240 V / 15 A outlet. *Note: None-standard voltage is also available.*

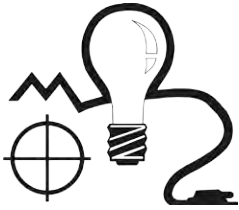

All electrical connections to the IST cabinet should be made by a qualified electrician and must comply to the codes, standards, and procedures specified by the local authority having jurisdiction.

The customer is responsible for providing appropriate disconnecting means adjacent to the equipment for each incoming power circuit.

For detailed electrical connections wiring requirements, overload and starter, Refer to electrical drawings on pages 25 and 26.

It is important to connect the IST system to an Earth Ground to bleed off static electricity, which may be generated while blasting. The Earth Ground may also reduce the discomfort an operator may experience when static electricity is discharged.

VERIFY INSTALLATION

1. Check that all pipe and hose connections are tightly fastened and air tight.
2. Check that all electrical box covers are securely installed.
3. Check that the dust drum under the dust collector is sitting firmly and is center (if equipped).
4. Turn the cabinet snap switch to the "ON" position. The cabinet lights will power on and the dust collector fan and the reclaimers will start.
5. Set the blast air pressure regulator to the desired pressure
6. Insert both hands into the cabinet gloves, take the gun and press the foot pedal. Blasting will start, wait a few second and the blast flow will stabilize.
7. Turn the cabinet snap switch to the "OFF" position. Light will turn off and the dust collector fan and reclaimers will stop.

CAUTION : Disable and lock out power sources before performing service or maintenance work. Do not look into the fan outlet to determine the correct motor rotation. Check that the fan exhaust is clear of tools and free of debris before checking fan rotation. To avoid personal injury, stay clear of the fan exhaust.

PROPER AIRJET/NOZZLE COMBINATIONS

Make sure you have a proper air jet/nozzle combination. Standard IST suction cabinets are equipped with 3.9687 mm air jets and 7.9375 mm nozzles.

A simple way to determine if you have an incorrect combination is to check the abrasive regulator at the bottom of the reclaimers when the operator's pedal is depressed. If media is being discharged out of the regulator, there is an incorrect jet/nozzle combination or an obstruction inside the gun.

AIR CONSUMPTION TABLE (m³/h)

Orifice (mm)	Nozzle ID ³	PRESSURE						(kPa ²)
		276	345	414	483	552	689 ⁰	
3.175	6.350	20	25	29	32	36	44	(m ³ /h) ¹
3.968	7.937	32	39	46	51	98	120	
4.762	9.525	78	95	109	124	138	98	
5.556	11.112	64	78	88	102	110	136	
6.350	12.700	83	98	114	129	144	160	

⁰Optimal pressure. ¹ m³/h: cubic meters per hour.

²kPa: Pressure at nozzle in kilo Pascal. ³Nozzle ID: inside diameter of nozzle (mm)

LOADING ABRASIVE MEDIA

WARNING

Your suction cabinet is designed to operate efficiently with most **recyclable abrasive media** on the market. However, certain types such as sand, recycled glass or silica are not recommended and should not be used in our blast cabinet.

These abrasives generate very fine dust that may block the bag's pores, obstruct the ventilation system and cause dust accumulation inside the cabinet while in use. Instead, use reclaimable abrasives such as glass beads, aluminum oxide steel grit or plastic media.

For better results for the reclaiming process, **please call one of our technical representatives** if you have to use a different **type of abrasive** from the one your equipment has been set for at the factory.

Manufactured Abrasives

NAME	TYPE	SHAPE	HARDNESS SCALE	DENSITY KG/M ³	CONTENT SILICA	DUST FACTOR	MESH SIZE	REUSE FACTOR	AVAILABILITY
Aluminium Oxide	Oxide	Irregular	8 Mohs	1922	None	Low	6-600	Good	Good
Silicon Carbide	Carbide	Angular	9 Mohs	1602-1762	None	Low	6-600	Good	Good
Glass Beads	Silica	Spherical	5-6 Mohs	1602	0 free Silica	Low	20-325	Good	Good
Plastic Grit	Polyurethane	Angular	3-4 Mohs	929-961	None	Low	12-80	Good	Good
Chilled Iron & Steel Grit	Metallic	Angular	40-68 Rc Rockwell C	4005	None	Very Low	18-200	High	Good
Chilled Iron & Steel Shot	Metallic	Spherical	40-68 Rc Rockwell C		None	Very Low	7-200	High	Good

LOADING ABRASIVE MEDIA

Follow these steps to avoid locking the drain at the bottom of the cabinet when adding a brasive media.



1. Turn on the cabinet to activate the vacuum system.



2. **SLOWLY** add **approximately** half a bag of abrasive media through the grating inside the cabinet.



NOTE: Some cabinets can hold more than half a bag when added gradually.

OPERATION

Turn on compressed air and turn on lightning and motor with the power switch. Compressed air must be clean, dry, and oil free.



1. When using the unit, air pressure (**should not exceed 758 kPa**) Place the part to be treated inside the cabinet. The parts must be free of oil, grease, and moisture. Close and latch the cabinet load doors.
2. After closing the door, insert your hands into the two front glove openings. The blasting gun should be held firmly in one hand and the part to be treated in the other hand. The stream of abrasive should be oriented to the bottom of the working area.

3. Depressing blast control pedal will release compressed air flow to the blast gun. As the compressed air passes through the air jet, it creates a vacuum inside the gun and sucks up the media from the reclaimer and propels it out through the nozzle. Hold the gun or nozzle at a 90° angle to the part at a distance that produces the fastest results. The reclaimer screen will require periodic cleaning. The frequency of cleaning will depend on the volume of debris produced. See maintenance section at page 13 for more information.

4. After the media has blasted the part, the reclaiming system vacuums up the abrasive, dust and foreign material through the conduit at the bottom of the cabinet to the reclaimer. The reusable abrasive is separated from the dust and foreign material and is returned to the storage hopper for reuse. The dust bag or the cartridges of the dust collector, filters the dust and fine particles. Larger pieces of contaminants are trapped in the hopper's screen drawer.

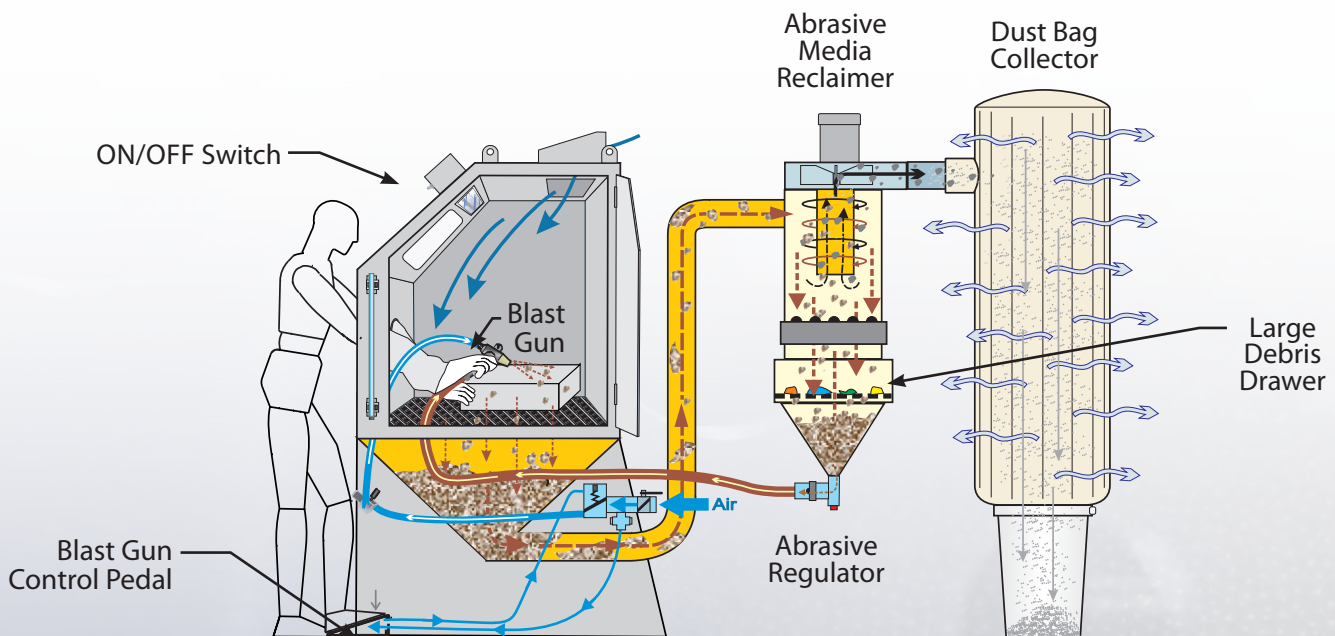

SHUT DOWN

1. Release the foot treadle. The blast will stop.
2. Once cleaning is finished, await 10 to 15 seconds before turning off the power switch and opening the door of the cabinet in order to allow the evacuation of dust in suspension.
3. Open the door and remove the treated parts from the blast cabinet.
4. Close air supply.
5. Turn power switch to the "OFF" position.
6. Empty the dust collector waste drum (Optional part). Replace the drum squarely on the dust drum platform and centered under the cover. The dust drum and cover must create an airtight seal.
7. Shake bags of your dust collector (disregard if you system is equipped with optional automatic bag shaker).

CHANGING THE MEDIA

When changing from one type or size of media to another, it can be extremely important to clean out the blast and recovery hoses, storage hopper, and the cabinet interior thoroughly to avoid contamination of the new media.

During normal sandblasting operation, the media should be replaced completely every 8 hours.

CLEANING THE SYSTEM

1. Turn the system off.
2. You need a container large enough to collect used media. Place the container under the AR $\frac{3}{4}$ valve (part 12, page 19).
3. Remove AR $\frac{3}{4}$ rubber plug (part 13, page 19), media will fall in your container.
4. Place the container under the corrugated dust conduct hose connecting the cabinet with the media reclaimer at the outlet connection of the cabinet.
5. Remove the corrugated dust conduct hose from the cabinet outlet and force the media to fall into the container. Remove the cabinet floor for better access to the bottom of the cabinet. Turn on system and press foot pedal, to make sure all media as been removed from the blast hose and nozzle.
6. Turn on system and press foot pedal, to make sure all media as been removed from the blast hose and nozzle.
7. Turn off system and put back AR $\frac{3}{4}$ rubber plug (part 13, page 19).
8. When cleaning is done put back everything in place.

RELOADING WITH NEW ABRASIVE MEDIA

Refer to Abrasive Loading procedure on page 9

RECLAIMER

Although the reclaimer is factory set, it is possible to increase the amount of fine dust to be sucked up by the dust bag or dust collector. Just move the rubber band to adjust the obstruction of the holes located behind it. There are **two methods to change those settings**.

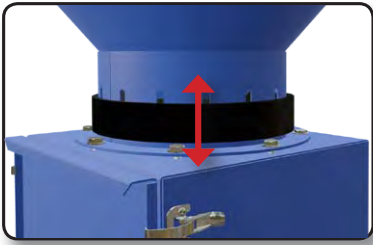

1. Adjustment of the SBR 3 mm x 51 mm rubber band

This adjustment will influence the quantity of dust that will be evacuated to the dust collector. Proceed step by step, moving the rubber band 6 mm at the time, covering or uncovering the slots behind it. **A wider opening will draw up more dust to the dust collector; a smaller opening will reduce that quantity. The equipment has to run for approx. two (2) hours** before any changes can be noticed. Repeat as needed.

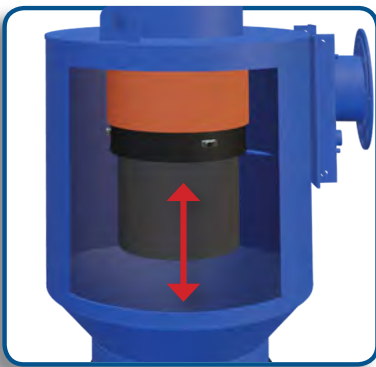

2. Adjustment of the telescopic tube, inside of reclaimer

If, after a few tests, the rubber band adjustments should prove to be insufficient, you will have to proceed to the telescopic tube adjustment. This will be necessary if you have to change the abrasive type or granulometry. Proceed step by step, moving the tube up or down, 25 mm at the time. The equipment has to run for approx. two (2) hours before any changes can be noticed. Repeat as needed. Moving the tube downward will increase the quantity of dust drawn up by the dust collector, moving it up will decrease that quantity.

AR 3/4 ABRASIVE REGULATOR

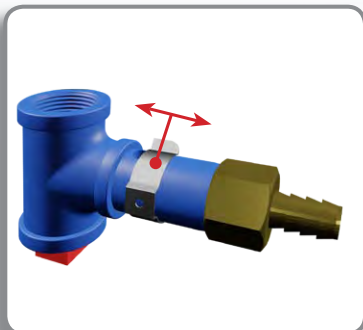

Located at the bottom of the reclaimer, the AR 3/4 abrasive regulator meters the amount of media discharged from the nozzle. Be sure that nothing seals off the hole completely. You can adjust the opening using the adjustable clamp that must be located over it, covering about 2/3 of the hole. A smaller opening will bring more abrasive to the nozzle; a wider opening will bring less abrasive. A complete opening or a complete covering will interrupt the abrasive flow. To insure the performances of your equipment, the compressed air supply must be clean and dry. Oil or humidity in the compressed air will cause an abrasive jam at the abrasive regulator level, reducing and even stopping the abrasive flow.

MAINTENANCE CABINET AND DUST COLLECTOR

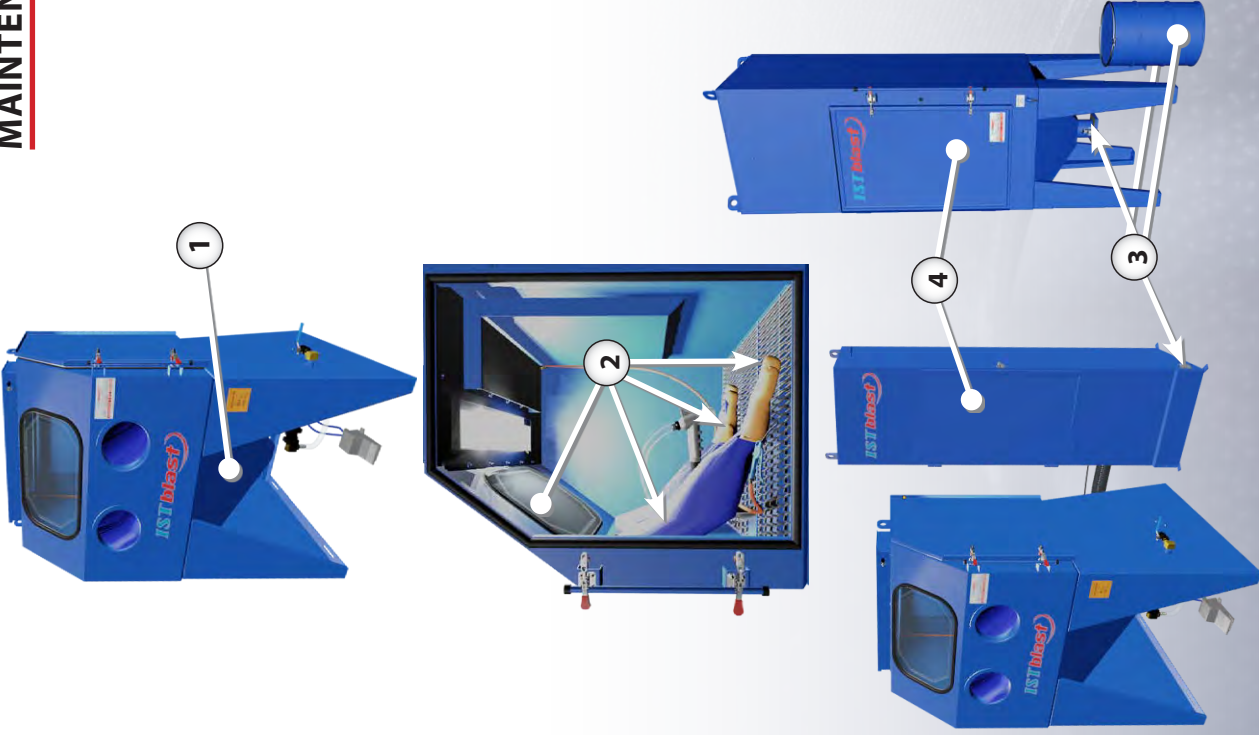

DAILY MAINTENANCE & OPERATION

1. Check both the quantity and quality of abrasive frequently. If required, clean out the system and reload with new media.
2. Check for wear on all parts in direct contact with the blasting action: nozzle, gloves, window, plastic shield, air-jet, gun etc. Special attention must be given to nozzle, nozzle ring and rubber protector to avoid premature wear of gun. Make sure ventilation inlet is always free of obstruction.
3. Empty dust drawer (DC50) or dust barrel (DC100) or dust collector's bottom hopper regularly.
4. After each use, shake bags inside the dust collector. Never shake bags while the cabinet is running. Never wash bags, instead use compressed use compressed air, **blowing from the outside to the inside of the bag**, (the opposite would clog the bag's pores and make it unusable).

WEEKLY

- **Sandblast Nozzle:** check the I.D. using a drill bit that is 3 mm wider than the original diameter of the nozzle. If the drill bit fits in, replace the nozzle. A worn nozzle will cause a drop of abrasive pull and velocity.
- **Abrasive Hose:** check abrasive hose for wear. It has to be changed before it gets any perforation. Give a special attention to parts of the hose that are curved.
- **Couplings and Gaskets:** check on a regular basis the hose couplings and gaskets for wear.
- **Media filters:** replace bags when the dust collector is unable to evacuate the dust cloud from the cabinet.

NOZZLE AND JET MAINTENANCE

Nozzle: check the nozzle regularly for wear using a drill bit **3 mm larger than the original nozzle diameter**

IT GOES THROUGH



WORN NOZZLE
TO BE REPLACED

DOES NOT GOES THROUGH

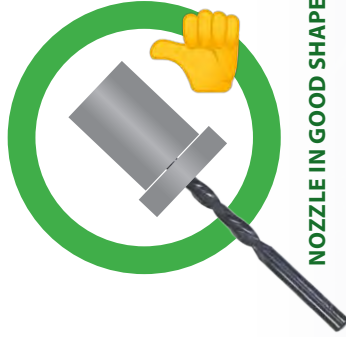

NOZZLE IN GOOD SHAPE

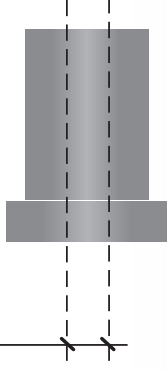

The diameter of the orifice should never exceed 3 mm of wear

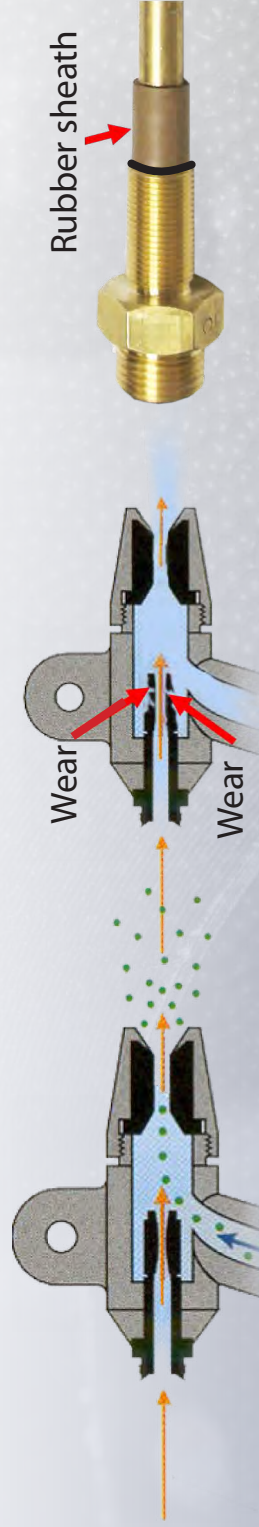

Air Jet : check regularly the wear of the injector and replace the **rubber sheath** if necessary to avoid wear from the outside



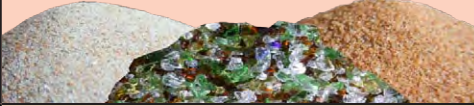
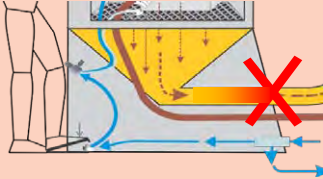
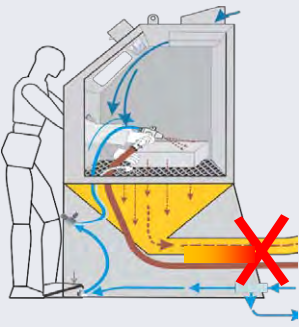

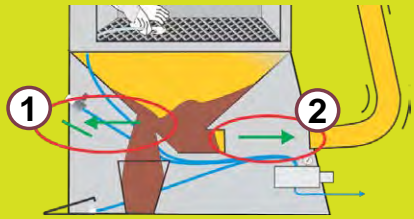
TROUBLESHOOTING

TYPE OF FAILURE	POSSIBLE CAUSE	SOLUTION
<p>Excessive dust in the cabinet (poor visibility) and / or very dusty abrasive (inefficient)</p>	<p>Non-recyclable abrasive³</p> 	<p>Follow abrasive drain and cleaning procedures and replace with recyclable abrasive.</p>
	<p>Suction hose (behind the cabinet) is partially or completely blocked</p> 	<p>Follow the procedures for resolving a clogged suction hose.</p>
<p>Suction hose outlet (behind the cabinet) partially or completely blocked</p> 	<p><u>Incorrect filling procedure:</u> too much abrasive or poured too quickly.</p> 	<p>Open the service door (1) and disconnect the abrasive suction hose (2) at the bottom of the hopper, remove the abrasive in excess and repeat the filling procedures properly.</p> 
	<p>Lack of debit (m³/h) (problem with the dust collector) which causes the outlet to become progressively blocked.</p>	<p>Follow the procedures for resolving a dusty cabinet as described above.</p>

³ Never use non-recyclable abrasive in IST cabinets, such as slag, silica sand, recycled glass, or other like them. IST cabinets are designed to be used exclusively with recyclable abrasive that generates a limited amount of dust. Ask your IST representative for more information.

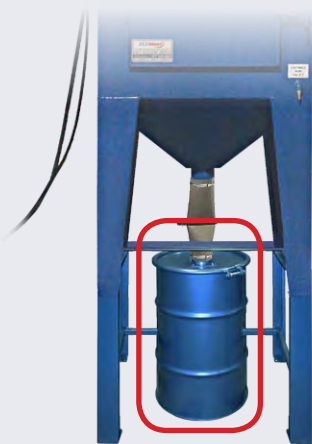
TROUBLESHOOTING (CONT'D)

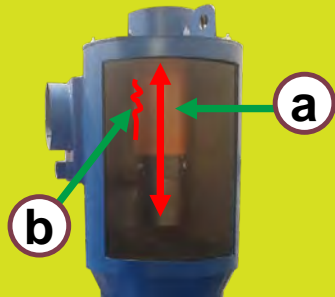
TYPE OF FAILURE	POSSIBLE CAUSE	SOLUTION
<p>"Good" abrasive ends up in the dust container of the dust collector</p> <p>Too much velocity (cfm) in the cyclone separator</p> 	<p>Incorrect adjustment of the rubber band of the cyclonic separator</p>	 <p>Cover gradually the holes with the rubber band to reduce the velocity flowing through the cyclonic separator</p>
	<p>The seal around the debris drawer is damaged or not properly installed</p>	 <p>Check the gasket around the drawer to make sure it is tight and replace if necessary.</p>
	<p>a. The central tube of the cyclonic separator is not adjusted properly due to a change of abrasive</p>	 <p>Contact your IST representative</p>
<p>b. The central tube of the cyclonic separator is perforated at the inlet of the separator</p>		

⁴The center tube of the cyclonic separator is factory adjusted for the abrasive specified at the time of purchase. If the abrasive changes during operation, it may be necessary to readjust the inner tube to alter the movement and flow of air within the cyclonic separator.

TROUBLESHOOTING (CONT'D)

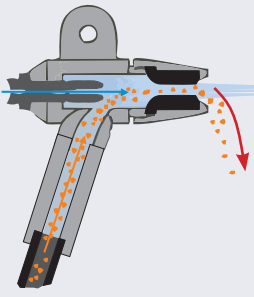
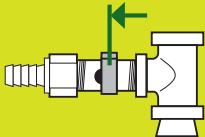
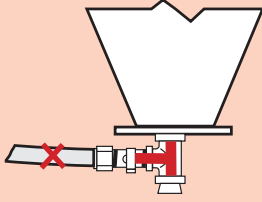
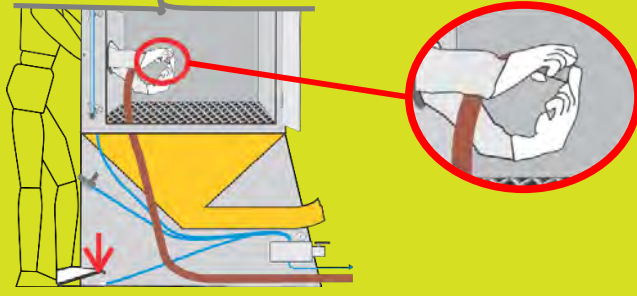
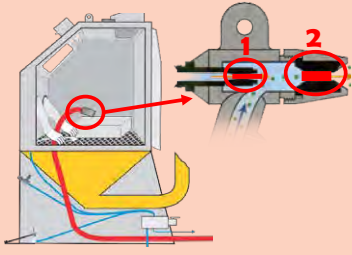
TYPE OF FAILURE	POSSIBLE CAUSE	SOLUTION
<p>Lack of abrasive in the mix (the nozzle blows mainly air)</p> 	<p>Incorrect adjustment of the AR $\frac{3}{4}$ Abrasive Valve</p>	 <p>Slightly close the opening of the AR $\frac{3}{4}$ valve and test again : Less air = more abrasive</p>
	 <p>Blocked AR $\frac{3}{4}$ abrasive valve and/or abrasive transport hose to nozzle</p>	<ol style="list-style-type: none"> Place a finger at the nozzle opening to obstruct the air outlet and activate the blaster to force air upstream of the nozzle to unblock it.  <ol style="list-style-type: none"> If this does not solve the problem, disassemble the AR $\frac{3}{4}$ abrasive valve and transport hose in an attempt to isolate the obstruction.
	<p>Abrasive transport hose to nozzle is obstructed (gun) or improperly installed. Wrong air jet to nozzle opening ratio.</p> <p>The ratio should be 2 to 1 (nozzle inner diameter = 2 times air jet inner diameter)</p>	<ol style="list-style-type: none"> Inspect the hose for holes (especially under the screened floor if it has been exposed to abrasive blasting) and replace as necessary. Remove the gun from the hose and insert it again to the bottom of the hose.
		<p>Disassemble the gun and check the nozzle and the air jet for wear:</p> <ol style="list-style-type: none"> If the nozzle is damaged by excessive wear from the outside, replace it. If the internal diameter of the nozzle exceeds 4 mm of its original size, replace it.

TROUBLESHOOTING (END)

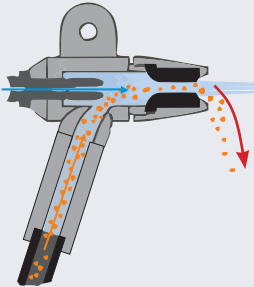
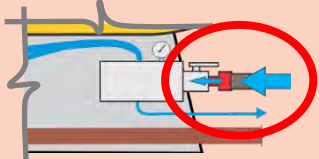
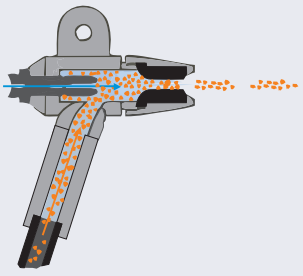
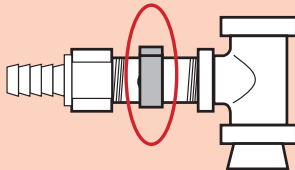
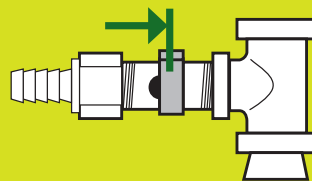
TYPE OF FAILURE	POSSIBLE CAUSE	SOLUTION																																																
<p>Lack of abrasive in the mix (the nozzle blows mainly air)</p> 	<p>Air supply problem (using a quick connect or a connection that creates a restriction to the cabinet air supply)</p> 	<p>Follow cabinet air connection guidelines (see chart page 8)</p> <table border="1" data-bbox="893 577 1485 766"> <thead> <tr> <th rowspan="2">Buse ID</th> <th colspan="6">Pression (psi)</th> </tr> <tr> <th>40</th> <th>50</th> <th>60</th> <th>70</th> <th>80</th> <th>100</th> </tr> </thead> <tbody> <tr> <td>1/4"</td> <td>12</td> <td>15</td> <td>17</td> <td>19</td> <td>21</td> <td>26</td> </tr> <tr> <td>5/16"</td> <td>19</td> <td>23</td> <td>27</td> <td>30</td> <td>34</td> <td>42</td> </tr> <tr> <td>3/8"</td> <td>27</td> <td>33</td> <td>38</td> <td>43</td> <td>48</td> <td>58</td> </tr> <tr> <td>7/16"</td> <td>38</td> <td>46</td> <td>52</td> <td>60</td> <td>65</td> <td>80</td> </tr> <tr> <td>1/2"</td> <td>49</td> <td>58</td> <td>67</td> <td>76</td> <td>85</td> <td>94</td> </tr> </tbody> </table> <p>And use only straight couplings as indicated in the manual</p>	Buse ID	Pression (psi)						40	50	60	70	80	100	1/4"	12	15	17	19	21	26	5/16"	19	23	27	30	34	42	3/8"	27	33	38	43	48	58	7/16"	38	46	52	60	65	80	1/2"	49	58	67	76	85	94
Buse ID	Pression (psi)																																																	
	40	50	60	70	80	100																																												
1/4"	12	15	17	19	21	26																																												
5/16"	19	23	27	30	34	42																																												
3/8"	27	33	38	43	48	58																																												
7/16"	38	46	52	60	65	80																																												
1/2"	49	58	67	76	85	94																																												
<p>Too much abrasive in the mix (the jet is jerky and discharges too much abrasive)</p> 	<p>Incorrect adjustment of the AR 3/4 abrasive metering valve</p> 	<p>Slightly open the orifice of the AR 3/4 valve : More air = less abrasive</p> 																																																

SCHEMATIC OF UNIT- EXPLODED VIEW & PARTS

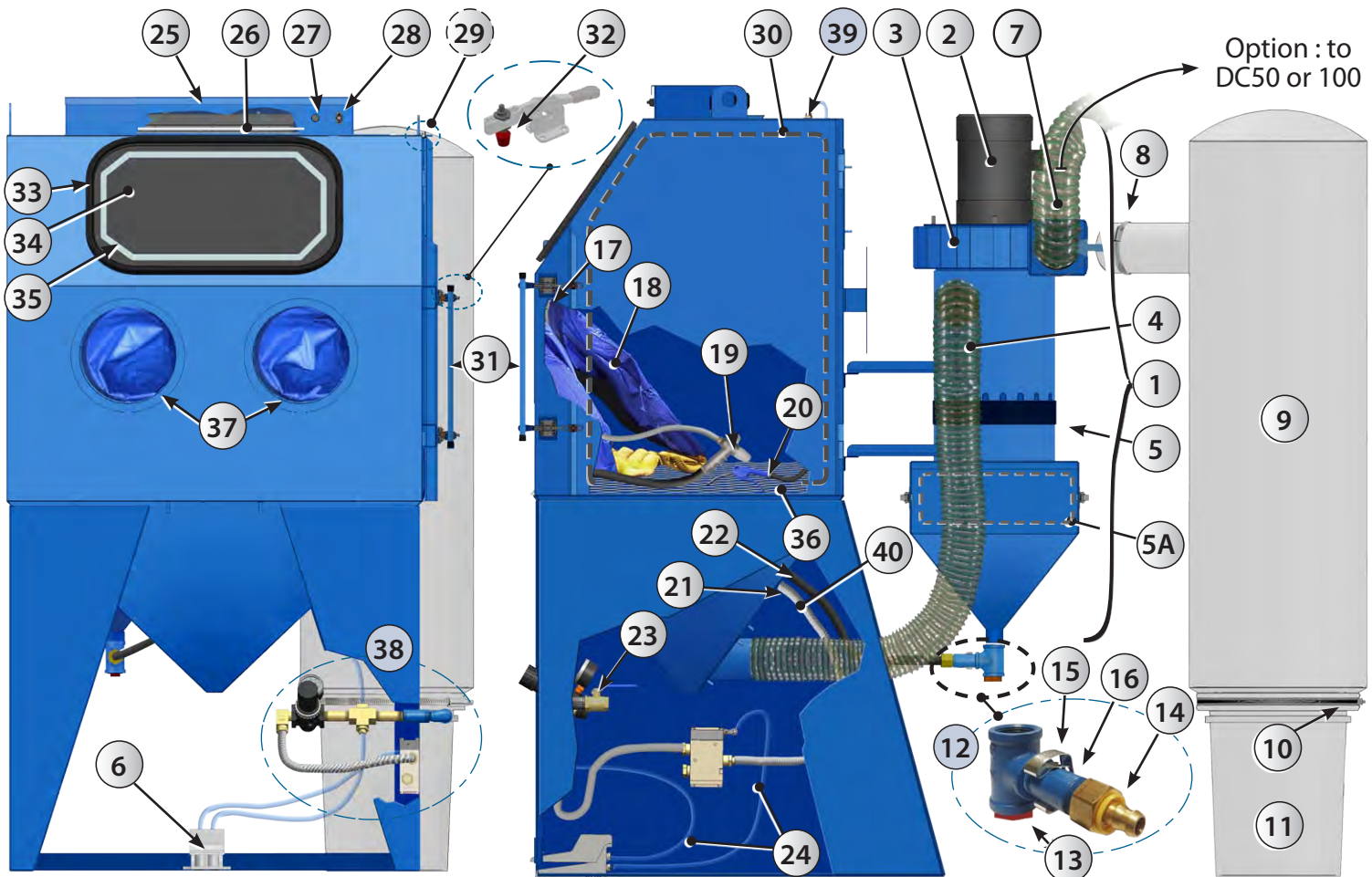

#	Part #	DESCRIPTION
1	609186	Complete reclaimer with RVM 10" motor
2	616311	½ hp 120 V / 1 ph / 60 Hz / 3450 rpm electrical motor
3	610525	½ hp Impeller
4	606161	3½" suction hose (sold by foot)
5	618334	⅛" x 2" width SBR Rubber
5A	618318	½" x ¼" x 37 ½" length Foam Rubber
6	*****	Factory fitted foot pedal (see details on page 21)
7	606167	Suction hose for 4" dust collector (option)
8	624117	#64 (4") T-Clamp
9	601315	DB-13 Dust bag
10	624137	T-188 (11¼") T-Clamp
11	601310	23L White Plastic Dust Bucket
12	608010	AR-¾" complete regulator
13	939143	Polyethylene threaded plug for AR ¾"
14	632960	PL ¾" FPT x ½" B Fitting
15	608011	Clip for AR ¾"
16	630505	SP ¾" x 3" lg. Nipple
17	624128	T-128 by 8" T-Clamp (sold by unit)
18	603212	8" I.D. x 30" length nylon sleeve gloves, (sold in pairs)
19	*****	Foot-operated G5 sandblasting gun (see page 20)
20	606148	½" Multi-purpose abrasive hose (sold by foot)
21	618126	½" (¾) Air Hose Grommet
22	618127	½" (7/8") Abrasive Hose Grommet
23	608102	½" FTP ball valve for customer air inlet

#	Part #	DESCRIPTION
24	324571	¼" Blue polyester tube (sold by foot)
25	617161	24" LED Lighting
26	610322	Protective glass for full 24" LED
27	616934	AGC 2 A - 250 V Fuse
27	616907	Fuse Holder
28	617014	ON/OFF switch
28	617019	Switch protection
29	600116	OPTION : security switch for ECAB 3-5-7
30	618321	"D" type rubber door seal (sold by foot)
31	610288	Standard ISTBLAST® door handle
32	910223	Door latch rubberized screw
33	610207	Rubber window seal
34	610205	14" x 22" Safety glass (laminated glass)
35	613026	Self-adhesive RPW 26 visor
36	610455	Expanded metal floor ECAB26365 - 26" X 36"
	610458	Expanded metal floor ECAB36365 - 36" x 36"
	610459	Expanded metal floor ECAB3648S - 36" x 48"
	610463	Expanded metal floor ECAB4848S - 48" x 48"
37	610229	8" Ø Glove strap (sold individually)
38	*****	Pneumatic Tree (See p. 21)
39	324503	Push-in ¼" Bulkhead Fitting for air gun (optional)
40	606104	½" white PVC air hose (sold by foot)

* Refer to the list on page 24 for spare parts relating to your equipment.

G5 BLAST GUN FOR SUCTION CABINET

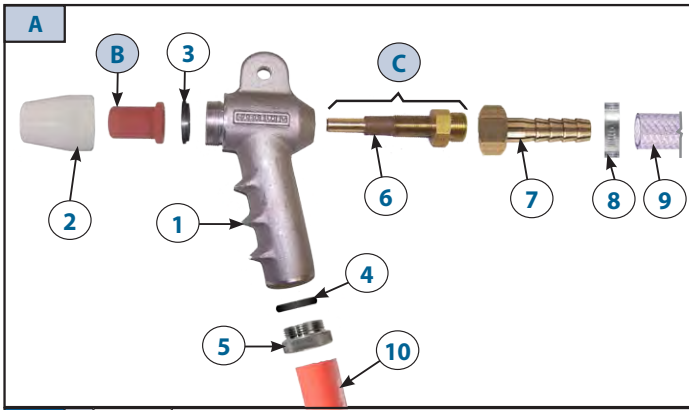

Pre-assembled gun	1	610119	Blast Gun Body only
	2	607037	Nozzle Adaptor
	3	618017	NW-2 Rubber Washer
	4	618112	O-Ring
	5	607038	Hose Adaptor
	6	618219	Rubber Protector
	7	632771	½" Brass Female Swivel Hose Barb
	8	624015	¾" O-Clamp
	9	606104	½" PCV Compressed Air Hose (sold per foot)
	10	606148	½" Multipurpose Abrasive Conveying Hose (sold per foot)

* Kits A- B-C, see list below

PROPER AIR JET/NOZZLE COMBINATIONS								
Complete blast guns (preassembled*)		Nozzles				Air jet (Complete)	Orifices ±	
G5	Nozzles	Type	Orifice	Length	Code			
A		B				C		
	610121	Ceramic	CN2-4	1/4"	1-¼"	605004	610116	1/8"
	610120	Ceramic	CN2-5	5/16"		605005	610117	5/32"
	610166	Ceramic	CN2-6	3/8"		605015	610109	3/16"
	610122	Ceramic	CN2-7	7/16"		605006	610118	7/32"
	610123	Tungsten	TN2-4	1/4"		605007	610116	1/8"
	610124	Tungsten	TN2-5	5/16"		605008	610117	5/32"
	610167	Tungsten	TN2-6	3/8"		605018	610109	3/16"
	610125	Tungsten	TN2-7	7/16"		605009	610118	7/32"
	610126	Boron carbide	BN2-4	1/4"		605010	610116	1/8"
	610127	Boron carbide	BN2-5	5/16"		605011	610117	5/32"
	610168	Boron carbide	BN2-6	3/8"		605021	610109	3/16"
	610128	Boron carbide	BN2-7	7/16"		605012	610118	7/32"

NOZZLE PROPERTIES

CERAMIC NOZZLE		
CN_		Cost-efficient nozzle for occasional use with soft abrasive media, such as glass beads, walnut shell, and steel shot / grit.

TUNGSTEN CARBIDE NOZZLE		
TN_		Higher durability nozzle for regular use with highly abrasive media, such as aluminum oxide and GMA Garnet.

FOOT PEDAL WITH PILOT VALVE

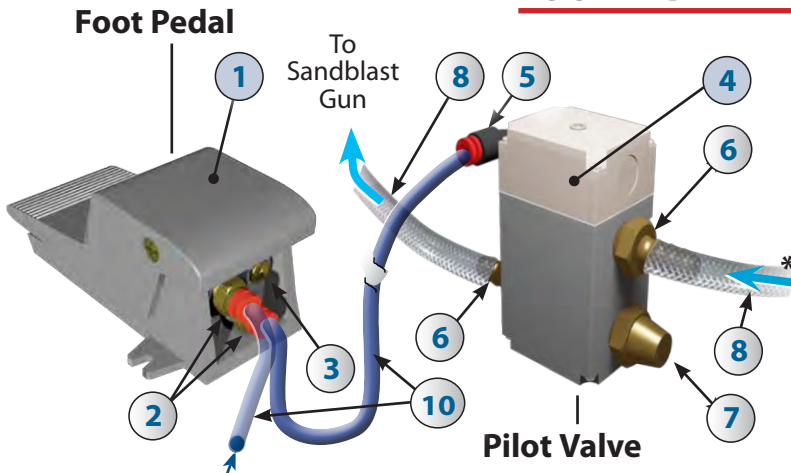

#	Part #	Description
1	610345	Pneumatic foot pedal (complete)
2	950264	1/4" Push-in Fittings
3	950265	1/4" Brass Plug
4	608519	1/2" NPT Pilot Valve
5	324561	1/8" NPT 1/4" Tube Push-in Fitting
6	632760	1/2" Hose Barb Fitting
7	608287	1/2" NPT Blowhole
8	606104	1/2" PVC Air Hose (sold by foot)

PNEUMATIC TREE & OPTIONS

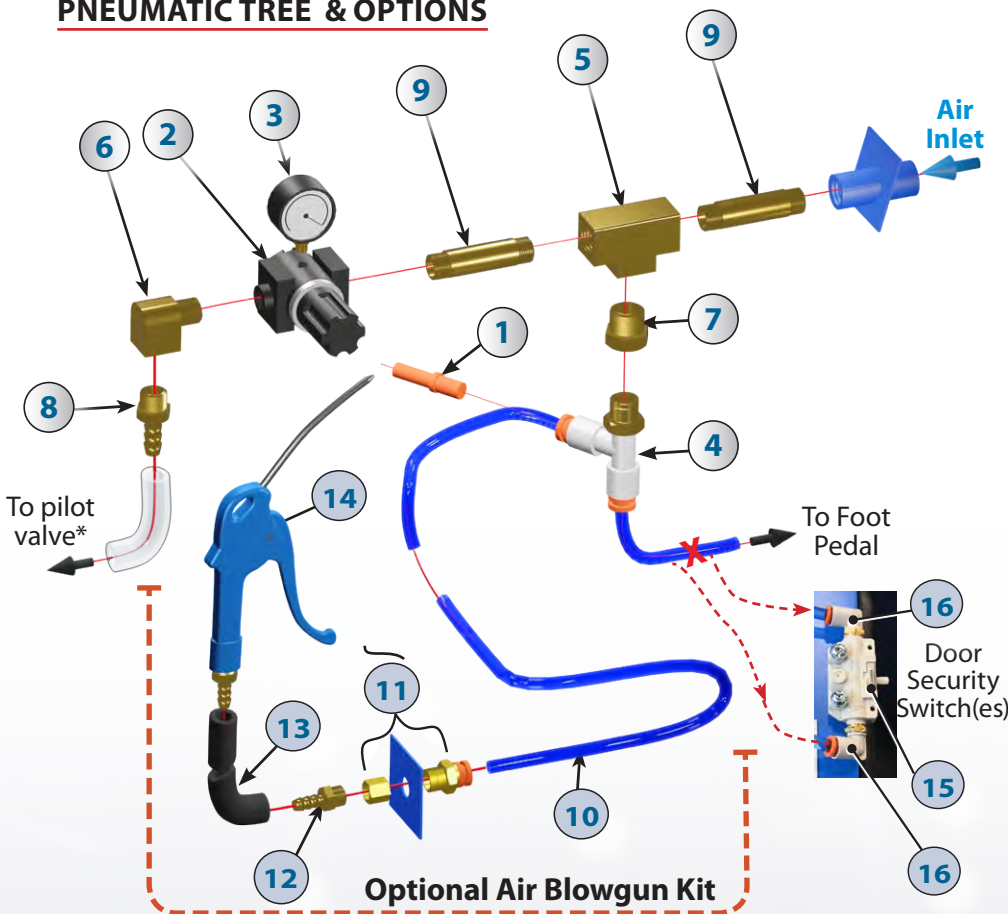

#	Part #	Description
1	324504	1/4" Plug
2	608022	1/2" Pressure Regulator
3	611022	1/4" NPT Pressure Gauge
4	612453	1/4" FPT "T" Push-in
5	632720	PL 1/2" FPT Brass "T"
6	632730	PL 1/2" MPT x 1/2" FPT @ 90° Elbow
7	632745	1/2" MPT @ 1/4" FPT Hex. Reducer
8	632760	1/2" MPT x 1/2" TU Hose Barb Fitting
9	932108	1/2" x 3" Lg. Nipple
STANDARD		
10	324571	1/4" Blue Poly. Tube (sold/fo.)
11	324503	1/4" x 1/4" TU Bulkhead Push-in Fitting
12	632270	1/4" MPT x 1/4" TU Hose Barb Fitting
13	606147	1/4" Multipur. Hose (sold/fo.)
14	610275	Air Blowgun c/w Fitting
Air Blowgun Kit (OPTIONAL)		
15	600116	Door Security Switch
16	324561	1/8" MPT x 1/4" TU FPT Push-in Fitting
Door Switch		

OPTION: SH5 BLAST GUN

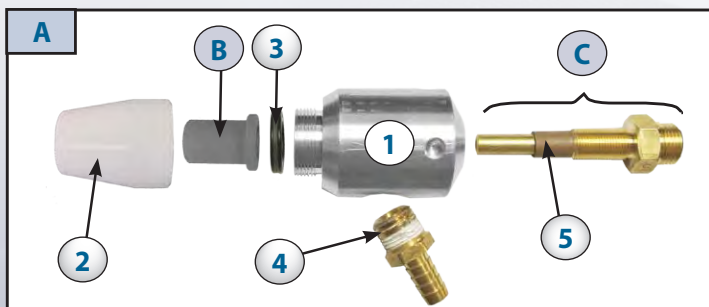

pre-assembled gun	#	Part #	Description
	1	610134	SH-5 Blast Gun Body Only
	2	607037	NA-G5 / SH5 Nozzle Adaptor
	3	618017	NW-2 Rubber Washer
	4	632760	1/2" Stem Brass Hose Barb
	5	618219	Rubber Protector

A, B, C: see chart page 20

-	600180	Option : ground	By/ft.
---	--------	-----------------	--------

DUST COLLECTOR SERIE DC50

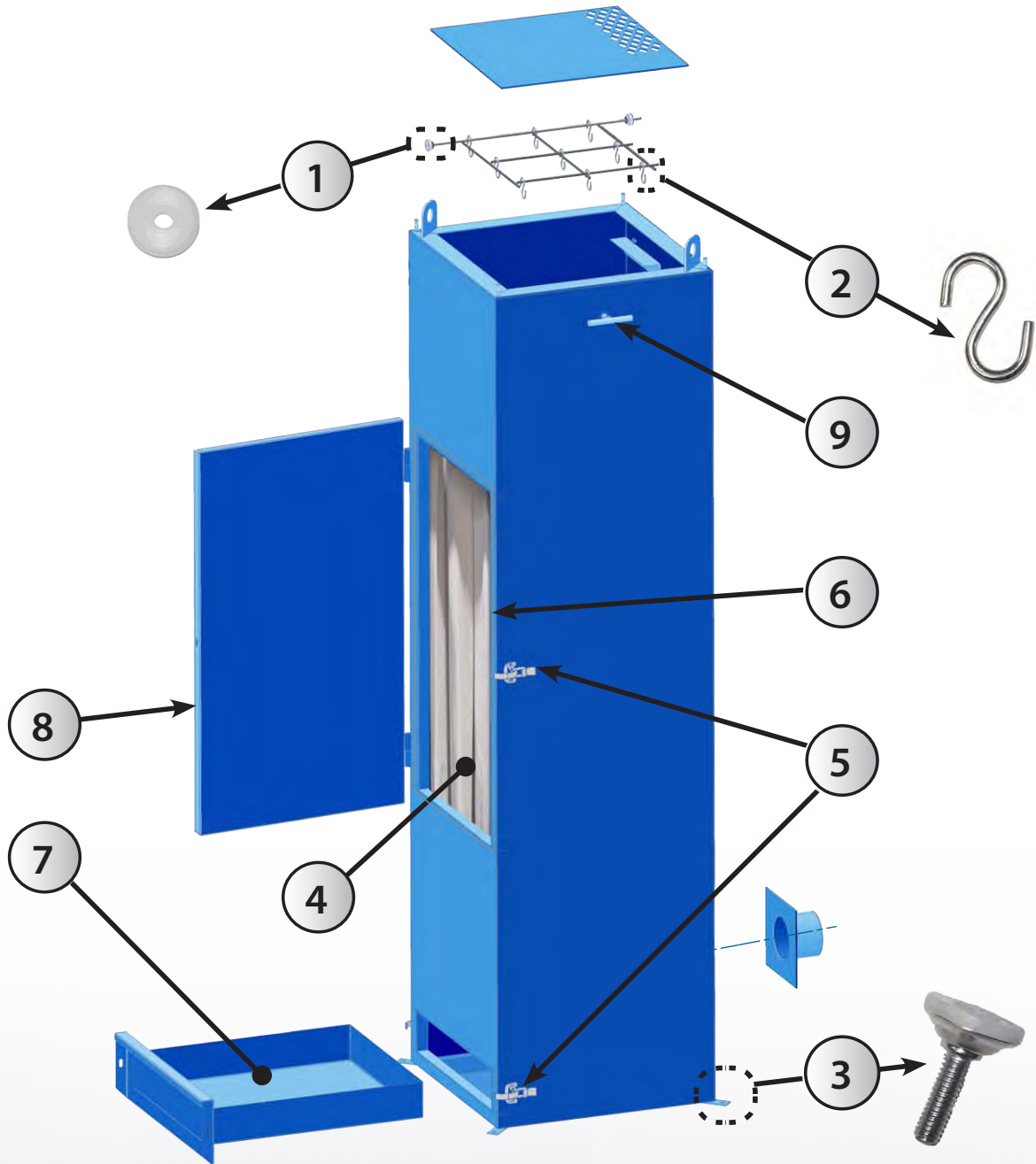

#	Part #	DESCRIPTION*
1	619006	ROLLER FOR BAGS RACK
2	601309	"S" HOOK
3	612427	LEVELING LEG
4	601316	DB6HP 56"LG X 5¼" Ø DUST BAG
5	610269	TOGGLE STEM

#	Part #	DESCRIPTION*
6	618321	TYPE "D" RUBBER SEAL (SOLD BY FOOT)
7	NPN	DUST DRAWER
8	NPN	ACCESS DOOR
9	NPN	MANUAL SHAKER HANDLE

(All items are sold by the foot or individually)

OPTIONAL BAGHOUSE DUST COLLECTOR DC100 - GENERAL PARTS LIST

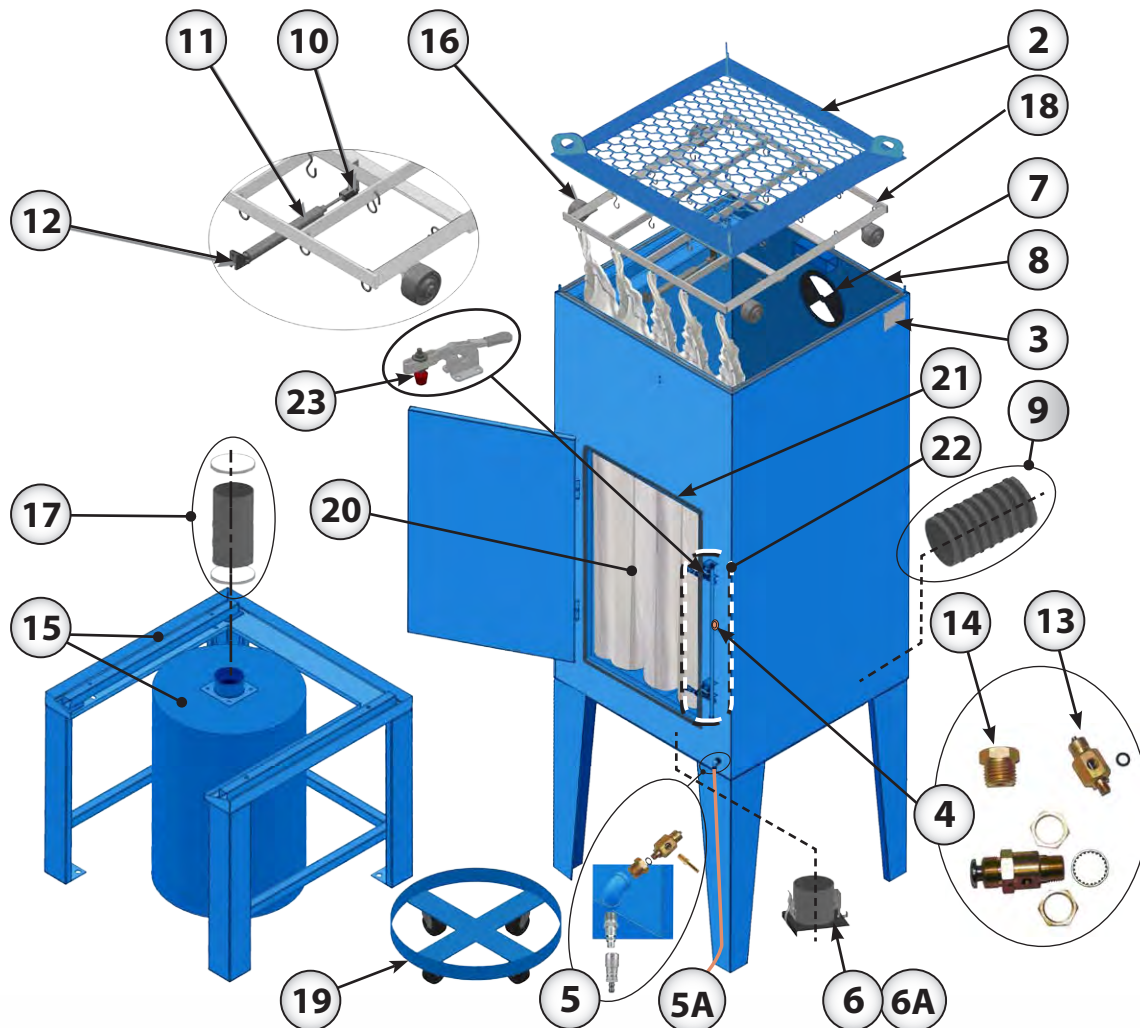

#	STOCK	DESCRIPTION	#	STOCK	DESCRIPTION
1	-/-	Hose & Clips: see parts page 15	10	608406	Clevis rod
2	601340	Top plate	11	608405	3/4" Ø x 3" stroke cylinder
3	NPN	Name plate	12	608407	Bracket for cylinder
4	608508	Pneumatic shaker button	13	608408	Flow adjust 10-32
5	NPN	Air inlet (quick connect 1/4" M # 607222, & 1/4" F # 607219)	14	608409	1/4" adaptor
5A	606112	Urethane hose 1/8"	15	601486	Dust barrel & extens. legs option
6	601371	Dust trap	16	619005	2" wheel
6A	618305	1/2" x 1" self-adhesive rubber foam (sold per foot)	17	609158	4" dust hose (SOLD PER FOOT)
7	610280	8" adjustable air inlet	18	601309	"S" hook
8	618318	1/4" x 1/2" self-adhesive rubber foam	19	501182	Optional trolley for 15 gal barrel
9	606171	7" dust conveying hose (sold per foot)	20	601316	DB 6 hp dust bags (Qty : 16)
9A	624127	7" Hose Clamp (sold per foot)	21	618321	Type "D" rubber (sold per foot)
			22	610287	Complete door handle
			23	610223	Door latch

RECOMMENDED SPARE PARTS

Description	Configuration	Part No	Qty
Cabinet			
Nylon Gloves	All models	603212	1
Nozzle 5/16" ID*		605005	1
Air Jet 5/32" ID*		610117	1
"Blast Hose (sold by foot)"	2636-2844-3636	606148	6
	3648-4848	606148	7
Safety Glass	Tous les modèles	610205	1
Window Shield		613026	5
Reclaiming Hose		606161	6
Dust Collector			
Filtering Bag	DB13	601315	1
	DC50	601316	9
	DC100/DCM100-4	601316	16
Dust Carrying Hose	DC50-DC100-DCM100-4	606167	6

*Corresponds to the standard items and may not reflect your actual cabinet configuration

PNEUMATIC DIAGRAM

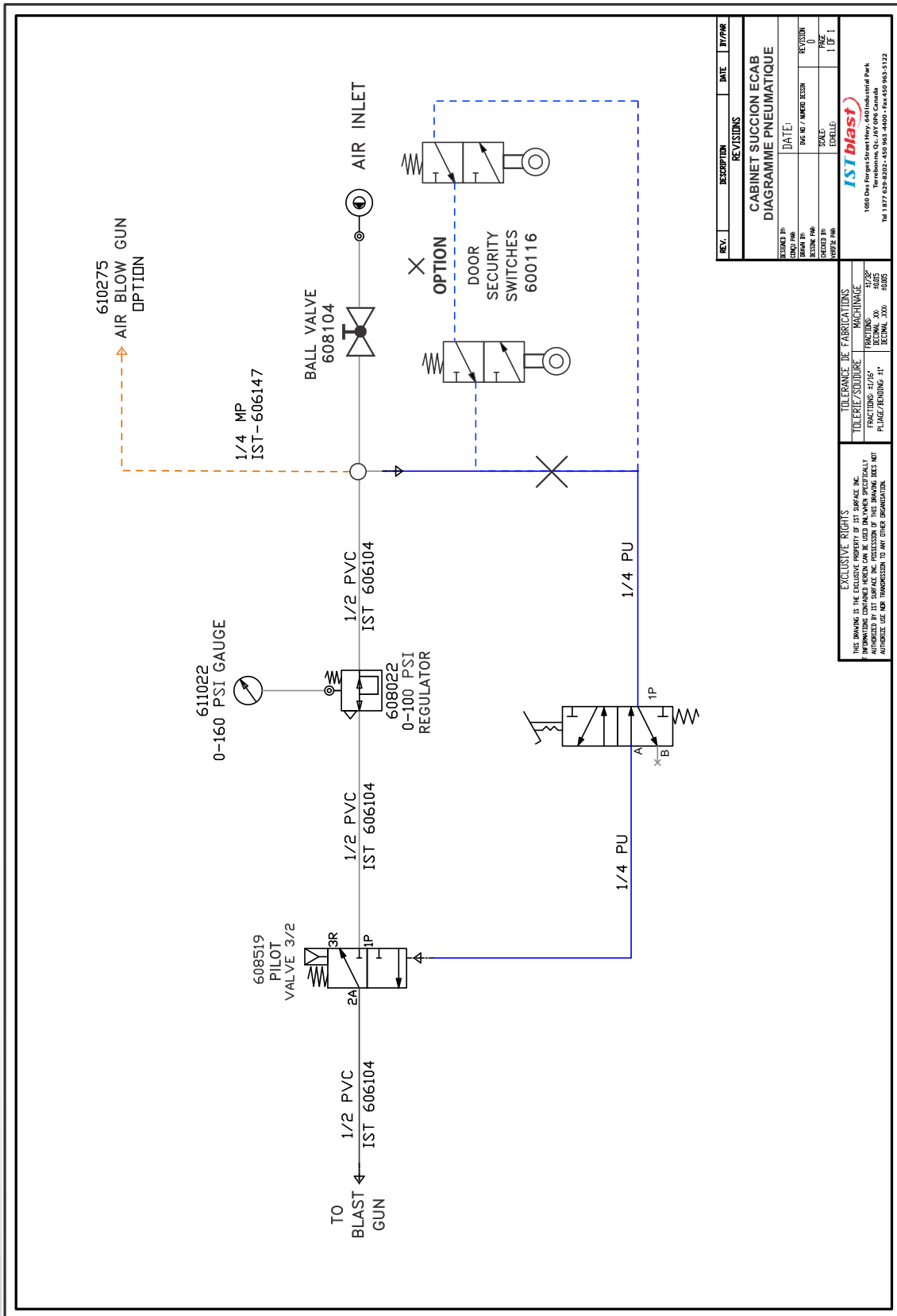

ELECTRICAL SCHEMATIC - 1 PH / 240 V - DRAWING

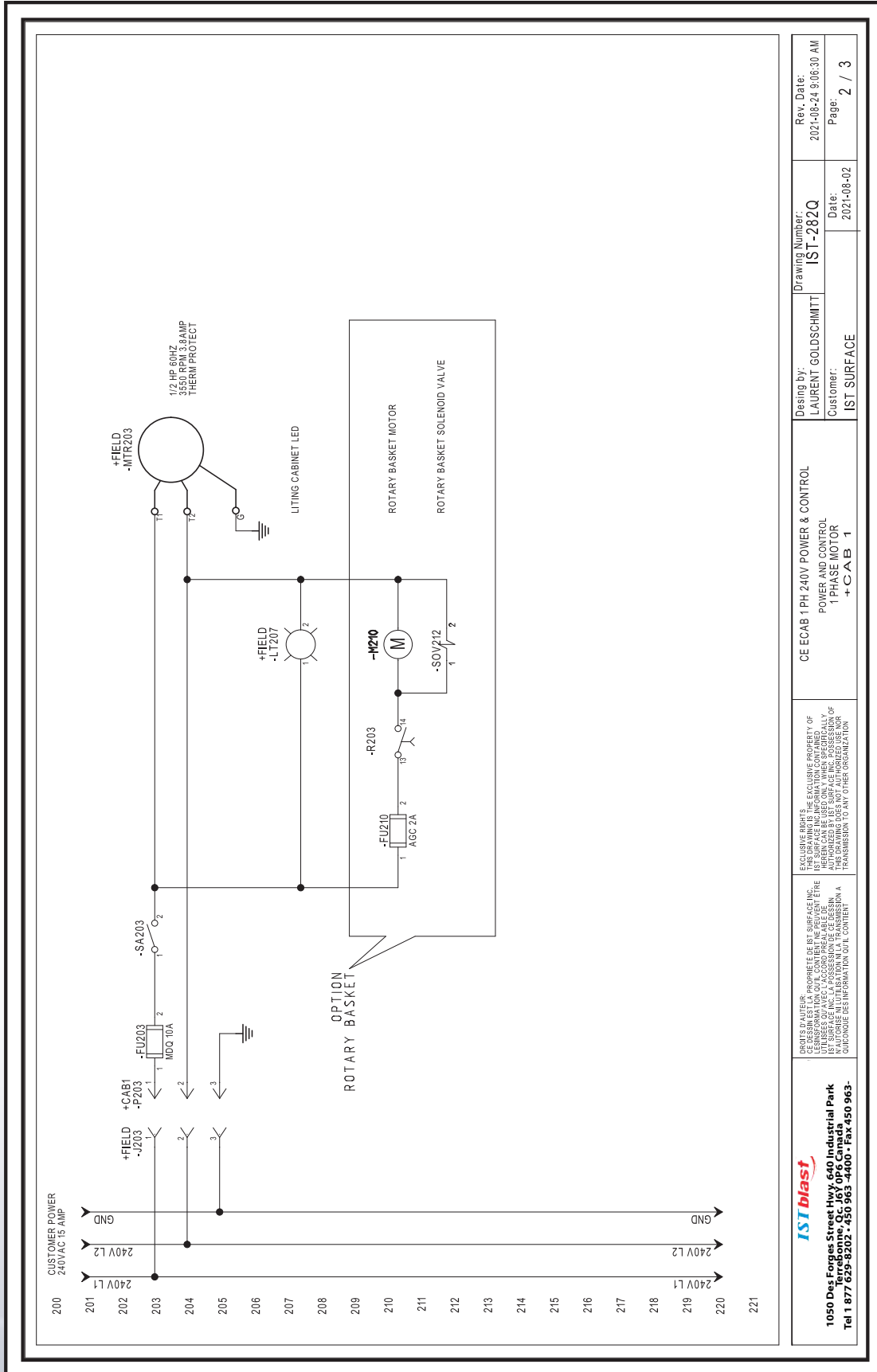

Desing by:
LAURENT GOLDSCHMITT

Drawing Number:
IST-282Q

Customer:
IST SURFACE

CE ECAB 1 PH 240V POWER & CONTROL
POWER AND CONTROL
1 PHASE MOTOR
+ C A B 1

EXCLUSIVE RIGHTS
THIS DRAWING IS THE EXCLUSIVE PROPERTY OF
IST SURFACE. NO PART OF THIS DRAWING
HEREIN CAN BE REPRODUCED OR TRANSMITTED
IN ANY FORM OR BY ANY MEANS, ELECTRONIC
OR MECHANICAL, INCLUDING PHOTOCOPYING,
RECORDING, OR BY ANY INFORMATION STORAGE
AND RETRIEVAL SYSTEM, WITHOUT PERMISSION
IN WRITING FROM IST SURFACE.

DROITS D'AUTEUR
CESSUS DROITS DE PROPRIÉTÉ EXCLUSIVE
D'IST SURFACE. AUCUNE PARTIE DE CE
DOCUMENT NE PEUT ÊTRE REPRODUITE NI
UTILISÉE EN AUCUNE MANIÈRE, ÉLECTRONIQUE
OU MÉCANIQUE, Y COMPRIS LA PHOTOCOPIE,
L'ENREGISTREMENT, OU PAR N'IMPORTE
QUELLE MÉTHODE DE STOCKAGE ET DE
RÉTRIBUTION D'INFORMATION, SANS
AUTORISATION ÉCRITE D'IST SURFACE.

ISTblast
1050 Des Forges Street Hwy 640 Industrial Park
Terrebonne, Qc J6Y 0P6 Canada
Tel 1 877 629-8202 - 450 963 4400 - Fax 450 963-

Rev. Date:
2021-05-24 9:06:30 AM

Date:
2021-06-02

Page:
2 / 3

ISTBLAST LIMITED WARRANTY

ISTblast warrants all equipment led in this manual which is manufactured by ISTblast and bearing its name, to be free from defects in material and workmanship on the date of sale by an authorized ISTblast distributor to the original purchaser for use. Notwithstanding any special, extended or limited warranty published by ISTblast will, for a period of TWENTY FOUR (24) months from the date of sale, repair or replace any part of the equipment determined by ISTblast to be defective. This warranty applies only when the equipment is installed, operated and maintained in accordance with ISTblast's written recommendations.

This warranty does not cover, and ISTblast shall not be liable for general wear and tear, or any malfunction, damage or wear caused by faulty installation, misapplication, abrasion, corrosion, inadequate or improper maintenance, negligence, accident, tampering, or substitution of non- ISTblast component parts. Nor shall ISTblast be liable for malfunction, damage or wear caused by the incompatibility with ISTblast equipment with structures, accessories, equipment or materials not supplied by ISTblast, or the improper design, manufacture, installation, operation or maintenance of structures, accessories, equipment or materials not supplied by ISTblast.

This warranty is conditioned upon the prepaid return of the equipment claimed to be defective to an authorized ISTblast distributor for verification of the claimed defect. If the claimed defect is verified, ISTblast will repair or replace free of charge any defective parts. The equipment will be returned to the original purchaser, transportation prepaid. If the inspection of the equipment does not disclose any defect in material or workmanship, repairs will be made at a reasonable charge, which charges may include the costs of parts, labor, and transportation.

THIS WARRANTY IS EXCLUSIVE, AND IS IN LIEU OF ANY OTHER WARRANTIES, EXPRESSED OR IMPLIED, INCLUDING BUT NOT LIMITED TO WARRANTY OF MERCHANTABILITY OR WARRANTY OF FITNESS FOR A PARTICULAR PURPOSE.

ISTblast's sole obligation and the buyer's sole remedy for any breach of warranty shall be as set forth above. The buyer agrees that no other remedy (including, but not limited to, incidental or consequential damages for lost profits, lost sales, injury to person or property, or any other incidental or consequential loss) shall be available. Any action for breach of warranty must be brought forward within two (2) years of the date of sale.

ISTblast MAKES NO WARRANTY, AND DISCLAIMS ALL IMPLIED WARRANTIES OF MERCHANTABILITY AND FITNESS FOR A PARTICULAR PURPOSE, IN CONNECTION WITH ACCESSORIES, EQUIPMENT, MATERIALS OR COMPONENTS SOLD BUT NOT MANUFACTURED BY ISTblast. These items sold, but not manufactured by ISTblast (such as electric motors, switches, hose, etc.), are subject to the warranty, if any, of their manufacturer. ISTblast will provide the purchaser with reasonable assistance in making any claim for breach of these warranties.

LIMITATION OF LIABILITY

In no event will ISTblast be liable for indirect, incidental, special or consequential damages resulting from ISTblast supplying equipment hereunder, or the furnishing, performance, or use of any products or other goods sold hereto, whether due to a breach of contract, breach of warranty, the negligence of ISTblast, or otherwise.

Report all accidents or "near misses" which involve ISTblast products to:

- **Technical Assistance**

The following items are not covered under the ISTblast warranty policy:

- **Parts or chassis replacement due to normal wears.**

Defective material or workmanship is not considered normal wear

INFORMATION / TECHNICAL ASSISTANCE

ISTblast is a registered trademark of:



For more information, pricing or technical support, contact your local IST distributor or call / fax to our Consumer Information num-

TEL.: 1 877 629-8202 & 450 963-4400

Or visit us at:
istsurface.com

OUR MAP LOCATION

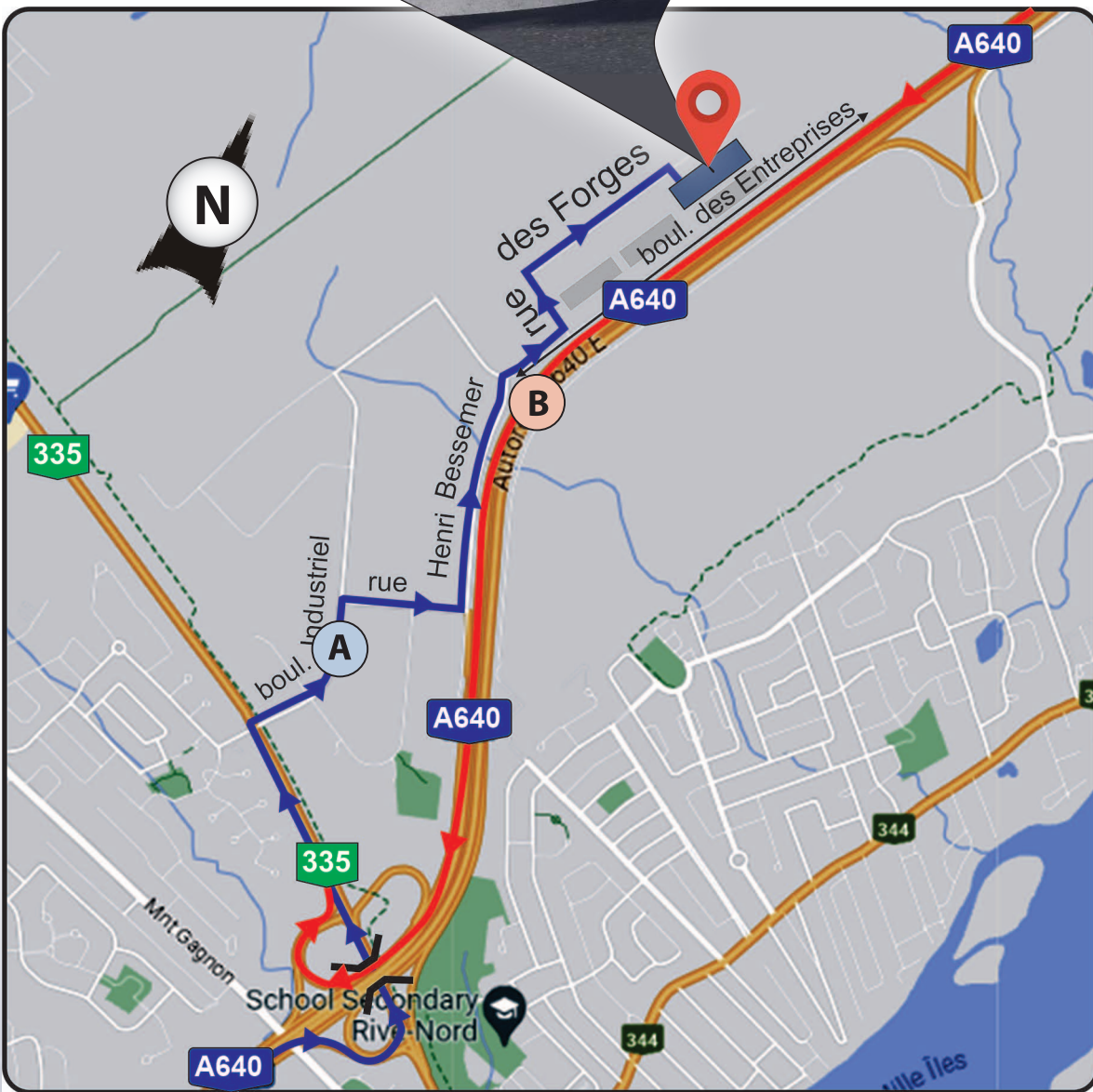

ABOUT THE COMPANY

WHO WE ARE

IST is a leading manufacturer of equipment for the surface treatment industry and the solvent recycling industry. Our extensive line of equipment includes batch units and automated machines designed to achieve the highest manufacturing standards.

MISSION

IST works tightly with their customers to transform industrial processes to improve their quality, productivity, and environmental footprint.

OUR SERVICES

- Custom Design & Fabrication
- Installation & Startup
- Preventative Maintenance Program
- Private Labels
- Testing Lab
- 24/7 Technical Support 5656

INDUSTRIES WE SERVE

- Aerospace & Aviation
- Aluminium Smelters
- Automotive
- Construction & Civil Engineering
- Flexography (labelling) & Lithography
- Foundry & Forge
- General Manufacturing
- Military
- Power & Energy
- Rail & Mass Transit
- Shipyards
- Wood finishing

